

ChromBook

Your guide to a fascinating world of chromatography.





Leading the way for over a century.



Our journey began in 1904 with the development of an aluminum oxide for adsorption chromatography. Over the decades, numerous products and techniques followed. Many set new milestones. Each was recognized as important progress in the field.





This spirit of innovation still continues relentlessly. Today, Merck Millipore is among the leaders in the science of liquid chromatography and is committed to the further development of sorbents, analytical and preparative columns, sample preparation, thin layer chromatography and biochromatography products. Whether for research and development, quality control or purification purposes, Merck Millipore products are most widely used throughout the world.

How did we get where we are today? Through uncompromising quality and a strong customer focus. From the very beginning, our highest priorities have been to develop tailored solutions for our customers' applications and provide specialized guidance throughout the process.

With this in mind, let us guide you through the diverse and fascinating world of chromatography at Merck Millipore. The following chapters will give you insights into the latest applications and detailed information about all our products. So no matter what your requirements are, ChromBook will lead you to your goal. Enjoy the journey.



ChromBook at a glance

01	Mobile Phases & Reagents	12
02	Sample Preparation	38
03	Thin Layer Chromatography	90
04	Analytical HPLC	128
05	Preparative HPLC	330
06	Ion Chromatography	360
07	Gas Chromatography	368
08	Indices & Contacts	388

Merck Millipore's high purity HPLC-solvents LiChrosolv® and Prepsolv® ensure separation results of excellent quality and provide highest safety in solvents-handling by combination with specially developed packaging and withdrawal systems. Merck Millipore Lab Water Systems provide on demand the best water quality of the most widely used solvent in the laboratory: water.

Merck Millipore offers a top quality portfolio with EXTrelut® for solid phase supported liquid-liquid extraction, LiChrolut® for solid-phase extraction, LiChrospher® ADS for on-line sample preparation, as well as Millex® and Samplicity™ for sample filtration.

TLC and HPTLC products from Merck Millipore: Top quality, convenient, easy-to-use for a broad spectrum of applications.

Merck Millipore ensures most reliable and reproducible HPLC and UHPLC separations by providing columns based on monolithic Chromolith®, particulate Purospher®, Superspher®, LiChrospher®, LiChrosorb®, zwitterionic SeQuant® ZIC®-HILIC and specialty sorbents, even for most challenging analyses.

A broad portfolio of standardized sorbents from Merck Millipore are available to provide a high degree of method reliability, direct transfer from analytical scale and optimized throughput per time.

For enhanced detectability and simpler analysis in suppressed ion chromatography Merck Millipore has developed the SeQuant® SAMS membrane suppressor, which is operated using the SeQuant® CARS continuous regeneration system.

Merck Millipore supplies a wide range of high-purity GC solvents (SupraSolv®, UniSolv®), GC sorbents, derivatization reagents and standards for accurate, reliable and reproducible results.

The chromatography products from Merck Millipore are not intended for use as medical devices for in-vitro diagnostic testing of human specimens within the meaning of European Directive 98 / 79 / EC. They are for research purposes only, for investigating in-vitro samples without any medical objective.



www.merck-chemicals.com/chromatography

Visit our website and browse e.g.

- Applications
 - Technical information
 - Information about current chromatography topics
 - Education material
- and much, much more ...

Mobile Phases & Reagents for HPLC and TLC	page 15
LiChrosolv®	page 16
Solvents for analytical chromatography	
LiChrosolv® hypergrade	page 21
A new standard in HPLC solvents	
Prepsolv®	page 24
Solvents for preparative chromatography	
Solvent Management System	page 25
Solvents handling in bottles	page 26
Options for solvents handling in barrels	page 28
Lab Water Purification	page 31
Production of ultrapure water suitable for HPLC	
Elix® Advantage system	page 34
Infinite water purification	
Milli-Q® Advantage system	page 35
User-adapted ultrapure water	
Milli-Q® Integral system	page 36
Integrated pure and ultrapure water	
LiChropur® reagents for analytical HPLC	page 37

Sample Preparation	page 42
EXTrelut® NT working principle	page 44
Liquid-liquid extraction in its most effective form	
EXTrelut® NT1, EXTrelut® NT3 and EXTrelut® NT20	page 45
EXTrelut® NT refill packs and bulk materials	page 46
EXTrelut® NT accessories	page 47
Important EXTrelut® NT extraction parameters	page 48
LiChrolut®	page 50
LiChrolut® selection guide	page 51
LiChrolut®	page 52
Solid-phase extraction (SPE) with LiChrolut® - the reliable and rapid route to successful sample preparation	
LiChrolut® EN	page 53
Highest capacity for solid-phase extraction	
LiChrolut® extraction unit and drying attachment	page 56
LiChrolut® operating principle	page 57
LiChrospher® ADS	page 58
LiChrospher® ADS	page 60
For direct in-line sample preparation of untreated bio-fluids	
LiChrospher® ADS working principle	page 62
Ion exchangers and working principle	page 66
Application guide	page 67
Ion exchangers	page 68

Millex® Syringe Filters _____ Filter with confidence	page 72
Millex® Syringe Filters _____ Sample preparation for chromatography	page 73
Millex® Syringe Filters _____ Sample preparation for UHPLC	page 76
Millex® Syringe Filters _____ Automation-compatible filter	page 80
Samplicity™ Filtration System _____ Break free from routine sample filtration	page 82
Millex Samplicity™ Filters _____ Provide maximum versatility with highest quality.	page 85
Samplicity™ Filtration System _____ Now you can truly do more with less.	page 88

03

Thin Layer Chromatography 90

www.merck-chemicals.com/thin-layer-chromatography

Thin Layer Chromatography _____	page 93
Classical silica TLC plates (TLC) _____ For versatile and reliable routine analysis of a broad range of substances	page 94
Aluminium oxide TLC plates _____ For basic and neutral compounds using different pH conditions	page 97
Kieselguhr and mixed layer plates _____ For specific applications	page 98
High performance silica plates (HPTLC) _____ For fast analysis of complex samples for manual or instrumental use	page 99
LiChrospher® HPTLC _____	page 102
RP-modified silica plates (TLC and HPTLC) _____ Free choice of solvent system for special separations and as pilot method for HPLC	page 104
CN-, Diol- and NH ₂ -modified plates (TLC and HPTLC) _____ For special separation problems	page 107
Cellulose TLC and HPTLC _____ For analysis of polar substances	page 109
PEI (Polyethylenimine) Cellulose _____ For specific separations by ion-exchange chromatography	page 111
Concentrating zone plates (TLC, HPTLC, PLC) _____ Quick and easy sample application even of large volumes of diluted samples	page 112
ProteoChrom® HPTLC plates _____ For peptide analysis	page 115
Multiformat plates (TLC and HPTLC) _____ Multiple sizes in one single glass plate	page 118
GLP plates (TLC and HPTLC) _____ With individual laser coding for GLP applications	page 119
Preparative layer plates (PLC) _____ For enrichment of target analytes in mg quantities and sample clean-up	page 120
Loose sorbents for preparation of TLC plates _____ Standardized sorbents for reliable results	page 121
Accessories _____	page 123
Technical appendix _____	page 124

Analytical HPLC _____	page 134
Method development & optimization _____	page 136
Column selection guide _____	page 152
Chromolith® _____	page 160
Speed and performance based on revolutionary monolithic silica technology	
Chromolith® CapRod® _____	page 161
Monolithic capillary	
Chromolith® HPLC columns _____	page 166
Speed and performance in monolithic form	
Chromolith® RP-18 endcapped _____	page 172
Chromolith® RP-18 endcapped columns are the fastest C18 columns in the world.	
Chromolith® RP-8 endcapped _____	page 188
Chromolith® Si _____	page 190
Chromolith® NH ₂ _____	page 192
Chromolith® guard cartridges and cartridge kits _____	page 195
Chromolith® column coupler _____	page 198
Chromolith® SemiPrep _____	page 200
Perfect scale-up from analytical to preparative LC	
Chromolith® Prep _____	page 204
Chromolith® – increase in speed, efficiency and productivity	
Purospher® _____	page 212
The all-around high performance solution for complex HPLC separations	
Purospher® STAR RP-18 endcapped _____	page 219
The versatility you need!	
Purospher® STAR columns for LC/MS applications _____	page 232
Purospher® STAR UHPLC columns for ultra fast HPLC _____	page 234
Where speed meets performance	
Purospher® STAR RP-8 endcapped _____	page 236
Optimized for more polar compounds	
Purospher® STAR Si (Silica) and NH ₂ (Amino-phase) _____	page 238
Purospher® RP-18 endcapped _____	page 240
Excellent peak symmetry with either basic or strongly acidic compounds	
Purospher® RP-18 _____	page 242
Accelerate and simplify method development for basic compounds	
Purospher® RP-18 HC _____	page 244
High resolution separation of explosives and related compounds	
Superspher® _____	page 246
Silica carrier for highly efficient separations	
Superspher® _____	page 248
For highly efficient HPLC of complex mixtures where high peak capacity required	
LiChrospher® _____	page 250
Silica carrier for constant top-rate results	
LiChrospher® 100 RP-18 and RP-18 endcapped _____	page 252
LiChrospher® WP 300 RP-18 _____	page 256
High-resolution separations of peptides and tRNA molecules	
LiChrospher® PAH _____	page 258
Indispensable in PAH trace analysis	

LiChrospher® 100 RP-8 and RP-8 endcapped	page 261
For reproducible reversed phase separation	
LiChrospher® 60 RP-select B	page 264
Excellent separations even with basic compounds	
LiChrospher® 100 CN	page 268
Excellent for complex samples with polar and hydrophobic characteristics	
LiChrospher® 100 NH ₂	page 269
A versatile sorbent for both reversed phase and normal phase chromatography	
LiChrospher® 100 DIOL	page 270
Excellent for complex samples with polar and hydrophobic characteristics and for exclusion chromatography	
LiChrospher® Si 60 and Si 100	page 271
LiChrosorb®	page 272
Irregular shaped silica sorbent	
LiChrosorb®	page 273
A successful packing material from the start	
Aluspher®	page 275
Alkaline stable HPLC separations	
Aluspher® RP-select B	page 276
A stable reversed phase stationary phase optimized for applications up to pH 12	
SeQuant® ZIC®-HILIC and ZIC®-pHILIC	page 278
The ideal columns for all classes of polar and hydrophilic compounds	
SeQuant® ZIC®-HILIC	page 282
High-performance columns for hydrophilic compounds	
SeQuant® ZIC®-pHILIC	page 287
Polymeric columns with extended pH stability for demanding separations of hydrophilic compounds	
Chiral stationary phases	page 288
Always the proper column for enantiomer analysis	
ChiraDex®	page 290
Specially for the separation of enantiomers	
Customized packings	page 292
Customized packings	page 293
Always the right column	
Accessories	page 296
manu-CART® cartridge holder for LiChroCART® cartridges	page 296
Accessories for particulate HPLC columns	
LiChroCART® cartridge	page 299
Accessories for particulate HPLC columns	
Hibar® column	page 301
Accessories for particulate HPLC columns	
LiChroTest®	page 306
Standard samples for HPLC system qualification	
Column care and use	page 308
Trouble-Shooting	page 316

www.merck-chemicals.com/preparative-hplc

Preparative HPLC	page 333
Aluminium oxide	page 334
For preparative chromatography	
Standardized silica gels	page 336
LiChroprep®	page 338
LiChrospher®	page 341
Other sorbents	page 342
For preparative chromatography	
Micro-crystalline cellulose	page 343
Florisil®	page 344
Chromolith® Prep	page 345
Chromolith® – increase in speed, efficiency and productivity	
Hibar® pre-packed columns	page 346
Hibar® customized pre-packed columns	page 347
25 and 50 mm internal diameter	
Scaling the separation	page 348

www.merck-chemicals.com/ion-chromatography

Ion Chromatography	page 362
SeQuant® SAMS & CARS suppressor system	page 363
High sensitivity and low background in anion chromatography	

www.merck-chemicals.com/gas-chromatography

Gas Chromatography	page 371
High purity solvents for gas chromatography	page 372
SupraSolv® Solvents for gas chromatography	page 373
SupraSolv® Solvents for headspace gas chromatography	page 376
UniSolv® Solvents for organic trace analysis	page 378
Sorbents for packed columns	page 382
Derivatization reagents	page 383
Reference substances	page 385

Subject index	page 389
Index of ordering numbers	page 392
Merck Millipore around the world	page 398
Analytical Application Finder and more educational material	page 405



Mobile Phases & Reagents

First stop: Merck Millipore laboratories, Darmstadt, Germany. Here you are bound to find many steady hands and agile minds – busy producing breakthrough mobile phases and reagents, which will be used to analyze chemical compounds in everything from food to pharmaceuticals. The task involves selecting the best raw materials and performing countless purification steps. This obsession with quality is the reason mobile phases from Merck Millipore are found in every HPLC laboratory worldwide. From a city in southern central in Germany to the rest of the globe ...

01

Contents

Mobile Phases & Reagents for HPLC and TLC page 15

LiChrosolv® page 16
Solvents for analytical chromatography

LiChrosolv® hypergrade page 21
A new standard in HPLC solvents

Prepsolv® page 24
Solvents for preparative chromatography

Solvent Management System page 25

Solvents handling in bottles page 26

Options for solvents handling in barrels page 28

Lab Water Purification page 31
Production of ultrapure water suitable for HPLC

Elix® Advantage system page 34
Infinte water purification

Milli-Q® Advantage system page 35
User-adapted ultrapure water

Milli-Q® Integral system page 36
Integrated pure and ultrapure water

LiChropur® reagents for analytical HPLC page 37

Mobile Phases & Reagents for HPLC and TLC

Introduction

Analytical HPLC has taken on a position of central importance in research and development, in pharmaceutical quality control and in environmental analysis. The various tasks involved place high requirements on the performance of the solvents used.

High purity, low UV absorbance, low particle count, low acidity and alkalinity combined with low evaporation residue are the basic preconditions for solvents to ensure reproducible and accurate chromatographic results, both in HPLC and TLC. These requirements are ideally fulfilled by **LiChrosolv® solvents**, which are manufactured using specially selected raw materials and purified in a multi-stage process with the highest batch-to batch consistency. **LiChrosolv® HPLC solvents** are manufactured to completely eliminate any trace contamination which may cause inaccurate results when using UV or fluorescence detectors.

The combination of classical Liquid Chromatography (LC) with Mass Spectrometry (MS) is fast becoming the dominant analytical tool for researchers in virtually every field of chemical analysis. LC-MS combines the advantages of a chromatographic separation with mass detection by MS: low detection limits and analysis of molecular structures e.g. identification and characterization of metabolites. **LiChrosolv® hypergrade solvents** are designed with very high UV-transmittance as well as very low metal ion content and very low LC-MS background signal. Application-oriented solvent quality ensures optimum chromatographic results, and avoids costly analysis repetition and loss of valuable samples.

Prepsolv® solvents are tailored to facilitate scale-up from analytical to preparative separations. With their special characteristics, e.g. of low residue on evaporation, this solvent quality ensures optimal product yield and column protection.

Solvent Management System

Merck Millipore's high purity solvents are available in returnable stainless steel barrels, as well as in glass and aluminum bottles. Whatever vessel is used, the Merck Millipore Solvent Management System is designed to ensure safe and contamination-free solvent usage in laboratory applications.

The Solvent Management System includes options for:

- safe carrying of bottles
- safe and contamination-free connection of bottles and barrels to instruments
- contamination-free waste bottle connection
- central storage in safety cabinets / with fume hood supply rooms

Lab Water Purification Systems

The production of "ultrapure water" using a Merck Millipore Lab Water Purification System is a crucial step prior to liquid chromatography to efficiently reduce water contaminants to minimum levels.

LiChrosolv®

Solvents for analytical chromatography

Modern analytical HPLC often uses gradient methods, which require higher solvent quality compared to isocratic methods. For this reason, we provide many LiChrosolv® solvents in both isocratic and gradient quality.

LiChrosolv® high purity solvents are available in an extensive product range: volumes of 1 liter, 2.5 liters and 4 liters are available in glass bottles, 5 liters in aluminum bottles and 10 liters, 30 liters and 185 liters in returnable stainless steel barrels. Higher volume vessels are available on request. The advantages of such barrels are described in our product information brochure "Accuracy – you can count on".

For information on safe and contamination-free solvent withdrawal from bottles and barrels, please refer to the section "Solvent Management System".



LiChrosolv® Acetonitrile hypergrade for LC-MS suitability in 1 and 2.5 L specially treated amber glass bottles.

► **Superspher®**
Silica carrier for highly efficient separations
page 246

► **LiChrosorb®**
Irregular shaped silica sorbent
page 272

Accessories for particulate HPLC columns:

► **LiChroCART®** cartridge
Different lengths, different internal diameter
page 299

Ordering information – LiChrosolv® A-C

Product	Ordering No.	Content / Packaging	Purity (GC) min. [%]	Evap. residue max. [mg/L]	Water max. [%]	Acidity max. [meq/g]	Alkalinity max. [meq/g]	UV-transm. at [nm]
Acetone	1.00020.1000	1 L GL	99.8	2	0.05	0.0002	0.0002	335 (50%), 340 (80%), 350 (98%)
	1.00020.2500	2.5 L GL						
	1.00020.4000	4 L GL						
	1.00020.5000	5 L AL						
	1.00020.9010	10 L ST						
	1.00020.9030	30 L ST						
Acetonitrile hypergrade, LC-MS suitability ¹⁾	1.00029.1000	1 L GL*	99.9	1	0.01	0.0001	0.0002	191 (25%), 195 (85%), 200 (96%), 215 (98%), 230 (99%)
	1.00029.2500	2.5 L GL*						
	1.00029.9010	10 L ST						
	1.00029.9030	30 L ST						
Acetonitrile gradient grade, suitable for UPLC UHPLC, Reag. Ph Eur ²⁾ , ACS ³⁾	1.00030.1000	1 L GL	99.9	2	0.02	0.0002	0.0002	193 (60%), 195 (80%), 230 (98%)
	1.00030.2500	2.5 L GL						
	1.00030.4000	4 L GL						
	1.00030.5000	5 L AL						
	1.00030.9010	10 L ST						
	1.00030.9030	30 L ST						
1.00030.9185	185 L ST							
Acetonitrile isocratic grade	1.14291.1000	1 L GL	99.8	4	0.05	0.0005	0.0002	195 (70%), 200 (90%), 240 (98%)
	1.14291.2500	2.5 L GL						
	1.14291.4000	4 L GL						
	1.14291.5000	5 L AL						
	1.14291.9010	10 L ST						
	1.14291.9030	30 L ST						
1.14291.9185	185 L ST							
Benzene	1.01768.1000	1 L GL	99.8	2	0.03	0.0002	0.0002	285 (70%), 290 (80%), 340 (98%)
	1.01988.1000	1 L GL						
1-Butanol	1.01988.1000	1 L GL	99.8	2	0.05	0.0002	0.0002	230 (75%), 240 (85%), 310 (99%)
	1.01988.2500	2.5 L GL						
tert-Butyl methyl ether	1.01845.1000	1 L GL	99.8	2	0.02	0.0002	0.0002	240 (60%), 255 (85%), 280 (98%)
	1.01845.2500	2.5 L GL						
	1.01845.9010	10 L ST						
	1.01845.9030	30 L ST						
	1.01845.9185	185 L ST						
1-Chlorobutane	1.01692.1000	1 L GL	99.8	2	0.01	0.0002	0.0002	227 (60%), 232 (80%), 250 (98%)
Chloroform stabilized with 2-methyl-2-butene and methanol	1.02444.1000	1 L GL	99.8	5	0.01	0.0002	0.0002	255 (70%), 260 (85%), 300 (98%)
	1.02444.2500	2.5 L GL						
	1.02444.4000	4 L GL						
	1.02444.9010	10 L ST						

All solvents are filtered through 0.2 µm. | GL = glass bottle | AL = aluminium bottle | ST = stainless steel returnable barrel | * specially treated amber glass |
 1) New extended specification | 2) Conforms to Acetonitrile for chromatography and Acetonitrile R1 acc. to Reag. Ph Eur | 3) Conforms to the requirements of ACS liquid chromatography suitability

Ordering information – LiChrosolv® C-L

Product	Ordering No.	Content / Packaging	Purity (GC) min. [%]	Evap. residue max. [mg/L]	Water max. [%]	Acidity max. [meq/g]	Alkalinity max. [meq/g]	UV-transm. at [nm]
Cyclohexane	1.02827.1000	1 L GL	99.9	2	0.01	0.0002	0.0002	230 (75%), 240 (90%), 260 (99%)
	1.02827.2500	2.5 L GL						
	1.02827.9030	30 L ST						
1,2-Dichloroethane	1.13713.1000	1 L GL	99.8	2	0.02	0.0002	0.0002	240 (85%), 245 (90%), 270 (99%)
Dichloromethane stabilized	1.06044.1000	1 L GL	99.9	5	0.01	0.0002	0.0002	240 (70%), 245 (90%), 260 (99%)
	1.06044.2500	2.5 L GL						
	1.06044.4000	4 L GL						
	1.06044.9010	10 L ST						
	1.06044.9030	30 L ST						
	1.06044.9185	185 L ST						
1,4-Dioxane	1.03132.1000	1 L GL	99.8	2	0.02	0.0002	0.0002	245 (50%), 270 (80%), 300 (98%)
	1.03132.2500	2.5 L GL						
Ethanol gradient grade, suitable for UPLC UHPLC	1.11727.1000	1 L GL	99.9	2	0.1	0.0002	0.0002	225 (60%), 240 (85%), 260 (98%)
	1.11727.2500	2.5 L GL						
	1.11727.4000	4 L GL						
	1.11727.9030	10 L ST						
	1.11727.9185	185 L ST						
Ethyl acetate	1.00868.1000	1 L GL	99.8	2	0.05	0.0002	0.0002	260 (50%), 265 (80%), 270 (98%)
	1.00868.2500	2.5 L GL						
	1.00868.4000	4 L GL						
	1.00868.9010	10 L ST						
n-Heptane	1.04390.1000	1 L GL	99.3	2	0.005	0.0002	0.0002	210 (50%), 220 (80%), 245 (98%)
	1.04390.2500	2.5 L GL						
	1.04390.9010	10 L ST						
	1.04390.9030	30 L ST						
	1.04390.9185	185 L ST						
n-Hexane	1.04391.1000	1 L GL	98.0	1	0.01	0.0002	0.0002	210 (50%), 220 (85%), 245 (98%)
	1.04391.2500	2.5 L GL						
	1.04391.4000	4 L GL						
	1.04391.5000	5 L AL						
	1.04391.9010	10 L ST						
	1.04391.9030	30 L ST						
	1.04391.9185	185 L ST						
Isohexane (C ₆ H ₁₄ Isomere)	1.04335.2500	2.5 L GL	99.0	2	0.005	0.0002	0.0002	210 (60%), 220 (80%), 245 (98%)
Isooctane	1.04717.1000	1 L GL	99.0	2	0.01	0.0005	0.0002	210 (50%), 220 (80%), 245 (98%)
	1.04717.2500	2.5 L GL						

All solvents are filtered through 0.2 µm. | GL = glass bottle | AL = aluminium bottle | ST = stainless steel returnable barrel

Ordering information – LiChrosolv® M-Z

Product	Ordering No.	Content / Packaging	Purity (GC) min. [%]	Evap. residue max. [mg/L]	Water max. [%]	Acidity max. [meq/g]	Alkalinity max. [meq/g]	UV-transm. at [nm]	
NEW Methanol hypergrade, suitable for LC-MS	1.06035.1000	1 L GL	99.9	1	0.01	0.0002	0.0002	210 (35%), 220 (60%), 230 (75%), 260 (98%)	
	1.06035.2500*	2.5 L GL							
	1.06035.9030	30 L ST							
Methanol gradient grade, suitable for UPLC UHPLC, Reag. Ph Eur, ACS	1.06007.1000	1 L GL	99.9	2	0.02	0.0005	0.0002	210 (20%), 220 (60%), 230 (75%), 235 (83%), 250 (95%), 260 (98%)	
	1.06007.2500	2.5 L GL							
	1.06007.4000	4 L GL							
	1.06007.5000	5 L AL							
	1.06007.9010	10 L ST							
	1.06007.9030	30 L ST							
Methanol isocratic grade	1.06018.1000	1 L GL	99.8	3	0.03	0.0005	0.0002	225 (50%), 240 (80%), 265 (98%)	
	1.06018.2500	2.5 L GL							
	1.06018.4000	4 L GL							
	1.06018.5000	5 L AL							
	1.06018.9010	10 L ST							
1-Propanol	1.01024.1000	1 L GL	99.8	2	0.02	0.0005	0.0002	230 (70%), 240 (80%), 270 (98%)	
	1.01024.2500	2.5 L GL							
	2-Propanol gradient grade, suitable for UPLC UHPLC	1.01040.1000	1 L GL	99.9	2	0.05	0.0005	0.0002	220 (80%), 230 (90%), 250 (98%)
		1.01040.2500	2.5 L GL						
		1.01040.4000	4 L GL						
1.01040.5000		5 L AL							
1.01040.9010	10 L ST								
1.01040.9030	30 L ST								
1.01040.9185	185 L ST								
Tetrahydrofuran not stabilized	1.08101.1000	1 L GL	99.9	1	0.02	0.0005	0.0002	218 (30%), 230 (35%), 250 (65%), 280 (95%)	
	1.08101.2500	2.5 L GL							
	1.08101.4000	4 L GL							
	1.08101.9010	10 L ST							
	1.08101.9030	30 L ST							
Toluene	1.08327.1000	1 L GL	99.9	2	0.05	0.0005	0.0002	300 (70%), 310 (80%), 350 (98%)	
	1.08327.2500	2.5 L GL							
	1.08327.4000	4 L GL							
NEW Water gradient grade, suitable for LC-MS and UPLC UHPLC	1.15333.1000	1 L GL	-	5	-	-	-	-	
	1.15333.2500	2.5 L GL							
	1.15333.9010	10 L ST							
	1.15333.9030	30 L ST							

All solvents are filtered through 0.2 µm. | GL = glass bottle | AL = aluminium bottle | ST = stainless steel returnable barrel | * specially treated amber glass |

1) New extended specification | 2) Conforms to Methanol R1 and R2 acc. to Reag. Ph Eur | 3) Conforms to the requirements of ACS liquid chromatography suitability

Specifications of LiChrosolv® gradient grade products for UPLC and UHPLC

Product	Cat. No.	Evaporation residue [max. mg/L]	Gradient at nm [max. mAU]			Fluorescence ¹ at nm [max. ppb]	
			210	235	254	254	365
Acetonitrile	100030	2	1.0	–	0.5	1.0	0.5
Ethanol	111727	2	–	5.0	2.0	–	–
Methanol	106007	2	–	2.0	1.0	1.0	0.5
2-Propanol	101040	2	–	1.0	1.0	–	–
Water	115333	5	5.0	–	0.5	1.0	0.5

¹ = calculated as Quinine in 0.05 mol/l H₂SO₄

Batch chromatogram (gradient profile) of LiChrosolv® Acetonitrile gradient grade [100030]

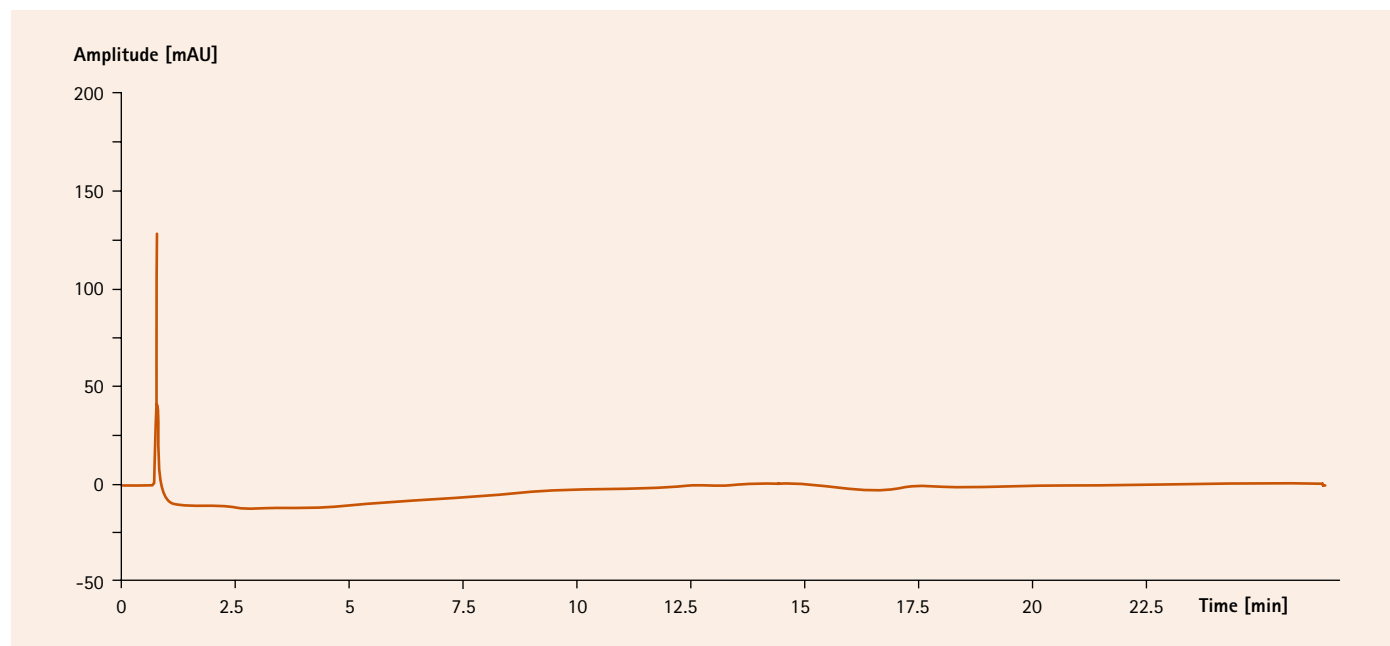

LiChrosolv® hypergrade

A new standard in HPLC solvents

Solvents for LC-MS and trace analysis with UV and fluorescence detection;

0.2 µm filtered – perfect for use in UPLC® and UHPLC

The determination of polycyclic aromatic hydrocarbons (PAHs) in environmental samples is one of the more complex problems to be solved by HPLC. LiChrosolv® hypergrade solvents enable analysis in the low ppb trace range and can be used for both the isocratic separation of 6 PAHs according to the German DIN method and the gradient separation of 16 PAHs according to the methods EPA 610 (analysis of drinking water) and EPA 550 + benzo(e) pyrene + perylene (analysis of waste water). Particularly when using wavelength switching with fluorescence detection, reliable results are highly dependent on the degree of purity of the solvents used. The LiChrosolv® hypergrade grade provides the highest degree of application reliability in HPLC gradient methods with subsequent UV or fluorescence detection. A new standard for HPLC solvent quality has been set. Acetonitrile LiChrosolv® hypergrade is manufactured using particularly precise performance processes and is tested using highly sensitive analytical methods for its suitability for the analysis of pesticides and PAHs by HPLC. By using the method of total fluorimetry in quality assurance, we are able to specify emission intensities in the range from 250 to 700 nm at excitation wavelength between 240 and 600 nm to be smaller than those produced by the following standard test solutions: a) quinine (1ng/ml in 0.05 mol/L H₂SO₄) and b) PAH (1:100000 in acetonitrile; NIST SRM 1647b). The optimized validation of the UV-VIS measuring technique enables us to describe practically ideal transmittance values. LC-MS is another analytical technique placing strong demands on solvent quality. LC-MS combines the advantages of a chromatographic separation with mass detection: low detection limits and analysis of molecular structures e.g. characterization of metabolites. LiChrosolv® hypergrade solvents ensure very high UV-transmittance, excellent baseline stability in gradient elution and also very low total ionic current (TIC) in LC-MS, thanks to high purity and low metal ion concentration. LiChrosolv® hypergrade solvents are the best choice for LC-MS applications.

Specifications of LiChrosolv® hypergrade solvents

Product	Purity [%]	Evap. residue max. [mg/L]	Water max. [%]	Acidity max. [meq/g]	Alkalinity max. [meq/g]	UV-transmission at nm
Acetonitrile	99.9	1	0.01	0.0001	0.0002	191 nm (25%)
						195 nm (85%)
						200 nm (96%)
						215 nm (98%)
						230 nm (99%)
Methanol	99.9	1	0.01	0.0002	0.0002	210 nm (35%)
						220 nm (60%)
						230 nm (75%)
						260 nm (98%)
Suitability for LC-MS			Mode: ESI 200 ul pos/APCI 200 ul pos	≤ 2 ppb		
			Mode: ESI 200 ul neg/APCI 200 ul neg	≤ 20 ppb		
			Na (Sodium)	≤ 100 ppb		
			K (Potassium)	≤ 10 ppb		

Specifications of LiChrosolv® water for chromatography (LC-MS)

Product	Colony count	Spec. conductance at 25°C [at time of manufacturing]	Evap. residue max. [mg/L]
Water	≤ 25 CFU/g	≤ 1 µS/cm	5
Suitability for LC-MS (detected by iontrap-MS)			
Intensity of single mass peak based on reserpine standard		APCI/ESI (+)	< 1 ppb
		APCI/ESI (-)	< 20 ppb

► Customized packings
Always the right column
page 292

Accessories for particulate HPLC columns:

► LiChroCART® cartridge
Different lengths, different internal diameter
page 299

Ordering information – LiChrosolv® hypergrade

Product	Ordering No.	Content
Acetonitrile	1.00029.1000	1 L*
	1.00029.2500	2.5 L*
	1.00029.9010	10 L
	1.00029.9030	30 L
Methanol	1.06035.1000	1 L*
	1.06035.2500	2.5 L*
	1.06035.9030	30 L

* specially treated amber glass

Ordering information – LiChrosolv® ready-to-use mixtures

Product	Ordering No.	Content	Assay TFA
Acetonitrile + 0.1% TFA (v/v)	4.80448.2500	2.5 L	0.095 - 0.105%
Acetonitrile + 0.05% TFA (v/v)	4.80672.2500	2.5 L	0.045 - 0.055%
Water + 0.05% TFA (v/v)	4.80170.2500	2.5 L	0.045 - 0.055%
Water + 0.1% TFA (v/v)	4.80112.2500	2.5 L	0.095 - 0.105%
	4.80112.9030	30 L	
Methanol + Water 30:70 (v/v)	4.80508.9030	30 L	-
Acetonitrile + Water 60:40 (v/v)	4.80853.4004	4 x 4 L	-
Acetonitrile + Water 80:20 (v/v)	4.80159.2500	2.5 L	-

Ordering information – LiChrosolv® water for chromatography (LC-MS)

Product	Ordering No.	Content
Water	1.15333.1000	1 L*
	1.15333.2500	2.5 L*
	1.15333.9010	10 L
	1.15333.9030	30 L

* specially treated amber glass

Separation examples with LiChrosolv® hypergrade

16 PAH acc. to EPA 610/550 + benzo(e)pyrene + perylene by fluorescence detection

Column	LiChroCART® 250-4 LiChrospher® PAH, 5 µm		
Mobile phase	A: Acetonitrile hypergrade LiChrosolv® B: Water LiChrosolv®		
Gradient	0-3 min 60% A 3-15 min 60% A – 100% A 15-50 min 100% A		
Flow rate	1.0 mL/min		
Detection	Programmed fluorescence detection		
	Peak No.	Ex nm	Em nm
	1, 3, 4	280	330
	5	246	370
	6	250	486
	7	280	450
	8	270	390
	9, 10	265	380
	11 – 15	290	430
	16, 17	290	410
	18	300	500
Temperature	20°C		

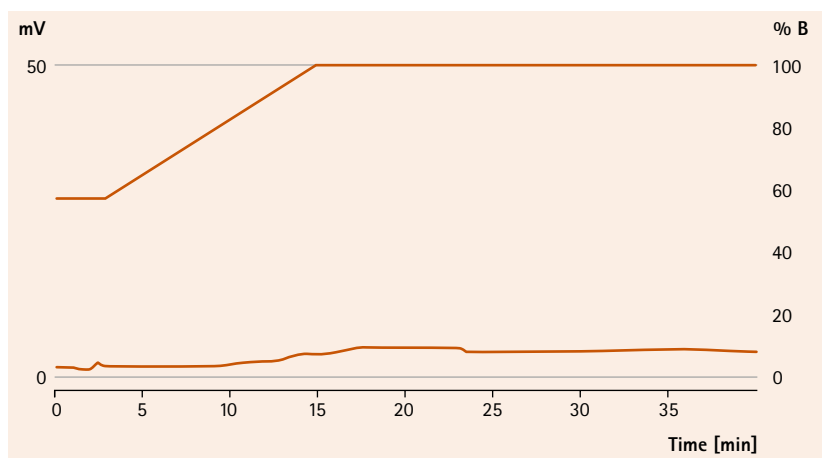

Blank value of Acetonitrile LiChrosolv® hypergrade in PAH determination according to EPA 610

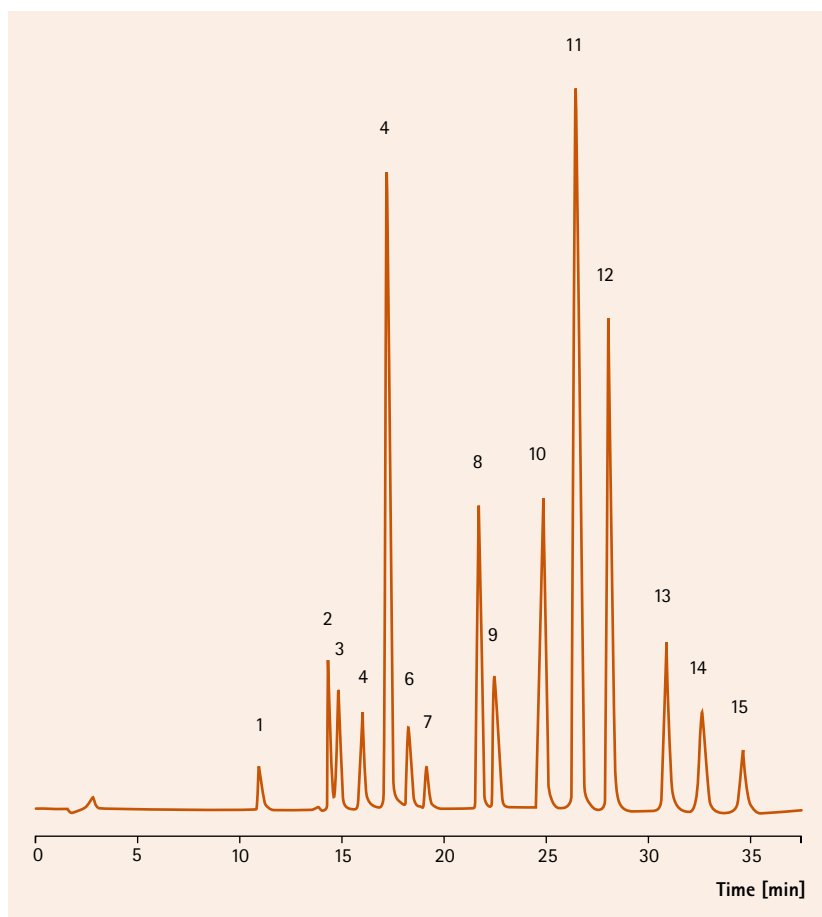

Application: Determination of 16 PAH acc. to EPA 610/550 with programmed fluorescence detection

In order to facilitate scale-up from analytical to preparative scale, Prepsolv[®] HPLC solvents are manufactured for the special requirements of preparative chromatography. These are characterized by an extremely low evaporation residue (< 1 mg/L) and a low water content. Preparative chromatography installations using significant quantities of high quality solvents have to ensure that the solvents are delivered and used in the right way to ensure optimum results.

Prepsolv[®] solvents for large-scale application are supplied in returnable stainless steel barrels, which are inert to the chemical contents, strong for repeated transport and are provided complete with two types of opening for versatility of connection. The extensive range of withdrawal systems ensure that the solvents can always be safely and easily used without any risk of contamination. Standard sizes are 30 liters, 185 liters and 1000 liters. If desired Merck Millipore will supply tailor-made volumes to fit the need of the individual customer.

Specifications of Prepsolv[®] solvents

Product	Purity (GC) min. [%]	Evap. residue max. [mg/L]	Water max. [%]	Acidity max. [meq/g]	Alkalinity max. [meq/g]	UV-transmission at nm	
						50%	98%
Acetonitrile	99.8	1	0.05	0.0005	0.0002	220	240
Methanol	99.8	1	0.05	0.0002	0.0002	225	265
2-Propanol	99.8	1	0.05	0.0002	0.0002	220	260
Ethyl acetate	99.8	5	0.05	0.0002	0.0002	270	300
n-Hexane	95.0	5	0.01	0.0002	0.0002	220	250

Ordering information of Prepsolv[®]

Product	Ordering No.	Contents	Packaging
Acetonitrile	1.13358.2500	2.5 L	glass bottle
	1.13358.9030	30 L	stainless steel returnable barrel
	1.13358.9185	185 L	stainless steel returnable barrel
	1.13358.9910*	1000 L	stainless steel 1000 L container
Ethyl acetate	1.13353.9030	30 L	stainless steel returnable barrel
n-Hexane	1.04394.9030	30 L	stainless steel returnable barrel
Methanol	1.13351.2500	2.5 L	glass bottle
	1.13351.9030	30 L	stainless steel returnable barrel
	1.13351.9185	185 L	stainless steel returnable barrel
	1.13351.9910*	1000 L	stainless steel 1000 L container
2-Propanol	1.13350.2500	2.5 L	glass bottle
	1.13350.9910*	1000 L	stainless steel 1000 L container

* customized

Solvent Management System

Options for safe solvent handling

Merck Millipore invests heavily in innovative solvent handling technology and product development, focussing on customer requirements and offering a wide range of products and accessories. Our primary goal is to help ensure user safety and the reliability of chromatographic results in the laboratory.

For many years, Merck Millipore has worked closely with customers to develop solvent withdrawal systems that are tailor-made according to packaging types.

Today, our broad range of withdrawal systems and containers is unrivalled in the industry. As a result, customers are assured that whatever the application, Merck Millipore can supply an integrated solution with the right container and the right withdrawal system with matched components for optimal results.

Benefits

- Safe and contamination-free solvent handling, minimizing health and environmental risks
- Easy handling
- Optimization of chromatographic reproducibility and accuracy of results
- Direct connections to instruments, central storage and supply
- Customized solvent supply solutions are available
- Cost saving



Carry solvent bottles safely

A primary aim of Merck Millipore is to focus on customer's safety. Based on this, Merck Millipore has developed a broad range of safety accessories according to official laboratory regulations, including "Working Safely in Laboratories – Basic Principles and Guidelines" (BGI 850-0e / GUV-I 850-0e).

Handling of solvents in breakable glass bottles has to be treated with particular caution. Merck Millipore provides a special safety carrier for glass bottles with the following properties:

- If the carrier is dropped, the glass bottle is specially protected against breakage, thanks to the high compression strength inlay
- The user is protected against contact with harmful solvents and solvents vapors by the leak-proof cover (special feature compared to the bottle baskets or open carriers from other suppliers)
- Even heavy bottles can be easily carried, thanks to the broad carrier handle
- Only special solvent-compatible materials are used in manufacture
- The inlay is specially shaped for the Merck Millipore 2.5 or 4 liter bottles and is also suitable for 1 liter glass bottles

Ordering information – Safety carrier

Product	Ordering No.
Safety carrier for 2.5 L Merck Millipore glass bottles	9.20078.0001
Safety carrier for 4 L Merck Millipore glass bottles	1.20080.0001



Benefits

Maximum user safety:

- no risk of cuts due to glass splinters
- no spillage of hazardous chemicals
- no health risk – no contact with solvents and vapors

High convenience due to broad carrier handle.

Direct connection of solvent-bottles to instruments

Direct connection of solvent bottles to instruments prevents both solvent vapor contaminating the laboratory and solvents themselves being contaminated from the environment.

The Merck Millipore HPLC adapter is specially designed to connect Merck Millipore HPLC solvents in bottles with S40 thread. It is made completely from high quality solvent-resistant PTFE and PE. The adapter ensures that the bottle is completely sealed and the solvents protected against contamination e.g. by dust. The filter technology prevents harmful emissions.

Benefits

- **Maximum protection of users and environment from harmful emissions, thanks to integrated air vent and air filter**
- **Reliable analytical results and cost efficiency, thanks to contamination-free solvent handling in a "closed system"**
- **Minimum downtime, thanks to fixed capillaries, thus also avoiding air absorption by the solvent**
- **Easy exchange of bottles due to free rotation (360°) of the HPLC adapter inlay**



HPLC adapter for solvent supply

The HPLC adapter for solvent supply (order no. 1.03830.0001) is equipped with an air valve that opens when the HPLC pump is working and allows filtered air to flow into the bottle. As soon as the pump stops, the membrane closes immediately, so that no harmful solvent vapor can exhaust. We recommend replacing the filter every 6 months (order no. 1.03832.0001).



HPLC adapter for waste solvent

The HPLC adapter for waste solvents (order no. 1.03831.0001) also keeps the system completely sealed. The overpressure, due to solvent entering the bottle, is released through an exhaust air filter. This filter contains special activated charcoal granules that prevent any harmful evaporation entering the lab. The exhaust air filter should also be exchanged regularly, depending on the application but not later than every 3 months (order no. 1.03833.0001).

Ordering information – Direct connection of solvent-bottles to instruments

Product	Ordering No.
HPLC bottle adapter with 3 tube connections 3.2 mm i.d., solvents supply by Merck Millipore-bottles	1.03830.0001
HPLC bottle adapter S40 with 3 tube connections and 1 connection for exhaust air filter, solvents disposal	1.03831.0001
Air valve for HPLC bottle adapter S40	1.03832.0001
Exhaust air filter for HPLC bottle adapter S40, disposal	1.03833.0001
Fittings for capillaries with 3.2 mm o.d., for HPLC bottle adapter S40 (pack of 10)	1.03834.0001
PTFE-ferrule for capillaries with 3.2 mm o.d., for HPLC bottle adapter S40 (pack of 10)	1.03835.0001
Blanking plug for capillary connections with 3.2 mm i.d., for HPLC bottle adapter S40 (pack of 10)	1.03836.0001

Direct withdrawal

Using specially developed withdrawal systems and safety accessories, HPLC solvents can be safely and easily withdrawn from stainless steel barrels without risk of contamination.

Withdrawal system with manual pressurization

- Suitable for 10 liter and 30 liter returnable stainless steel barrels
- Safe manual pressurization
- Includes exchangeable dip-tubes, clamp for outlet tube, ball valve, pump ball with rapid action connector and 3-way stopcock



Ordering information –

Withdrawal system for manual pressure build-up in barrels

Product	Ordering No.
Withdrawal system for solvents with manual pressure build-up for 10 L and 30 L stainless steel barrels with 2" opening	1.01123.0001
Antistatic device for earthing metal containers	1.07070.0001
Opening key	1.08803.0001

Withdrawal system with inert gas pressurization

- Suitable for all returnable stainless steel barrels
- Safe pressurization with inert gas (max. pressure 0.2 bar)
- Includes threaded adapter, spiral gas-feed tube, stainless steel coated PTFE-tube and self-closing filling nozzle
- Dip tube must be selected according to the barrel size



Ordering information –

Withdrawal system for inert gas pressurizing in barrels

Product	Ordering No.
Withdrawal system for stainless steel barrels and drums with threaded adapter, gas feeding tube and filling nozzle with flexible line (necessary in addition: dip tube suit the particular type of container)	1.06710.0001
Dip tube for 10 L stainless steel barrel for withdrawal systems with 2" threaded adapter	9.67100.1040
Dip tube for 30 L stainless steel barrel for withdrawal systems with 2" threaded adapter	9.67100.1041
Dip tube for 185 L stainless steel barrel for withdrawal systems with 2" threaded adapter	9.67100.1185
Antistatic device for earthing metal containers	1.07070.0001
Opening key	1.08803.0001
Pressure reducer with integrated overpressure relief	9.67100.9100

Safety cabinet storage

Using special installations our customers reach maximum safety standards in solvents handling. One important option is to store solvents barrels inside a safety cabinet.

A customized installation with stainless steel tubing directly from the safety cabinet to the fume hood avoids having any open solvent barrel in the laboratory during solvent withdrawal. One flexible filling nozzle placed inside the fume hood can be safely operated, while the solvent barrel itself is stored inside the safety cabinet. No hazardous solvent vapours enter the laboratory, thus ensuring maximum safety for users and environment! Please ask us for your individual installation!



Direct connection to instruments

Another option is to connect solvent barrels directly from the safety cabinet to the HPLC instrument, thereby offering maximum user safety and environment protection. Inert gas back-pressure can be applied to the barrel. Further process security can be provided by using the solvent level sensor technology. These customized installations are available on request – please contact your Merck Millipore supplier to discuss your individual requirements.

HPLC adapter for direct instrument connection



Merck Millipore has developed a special "S40-to-G2" adaptor 1.01111.0001 to connect solvents in barrels (10 or 30 liters) directly to HPLC instruments with the HPLC bottle connector 1.03830.0001 or 1.03831.0001 (see page 27).



Central storage

Customized central storage installations are always an option to meet the individual needs of our solvents customers. One option is the central storage of solvent barrels inside a safety room from which solvents are supplied to various laboratories.

Please talk to your Merck Millipore supplier to find out your individual installation for your maximum safety.

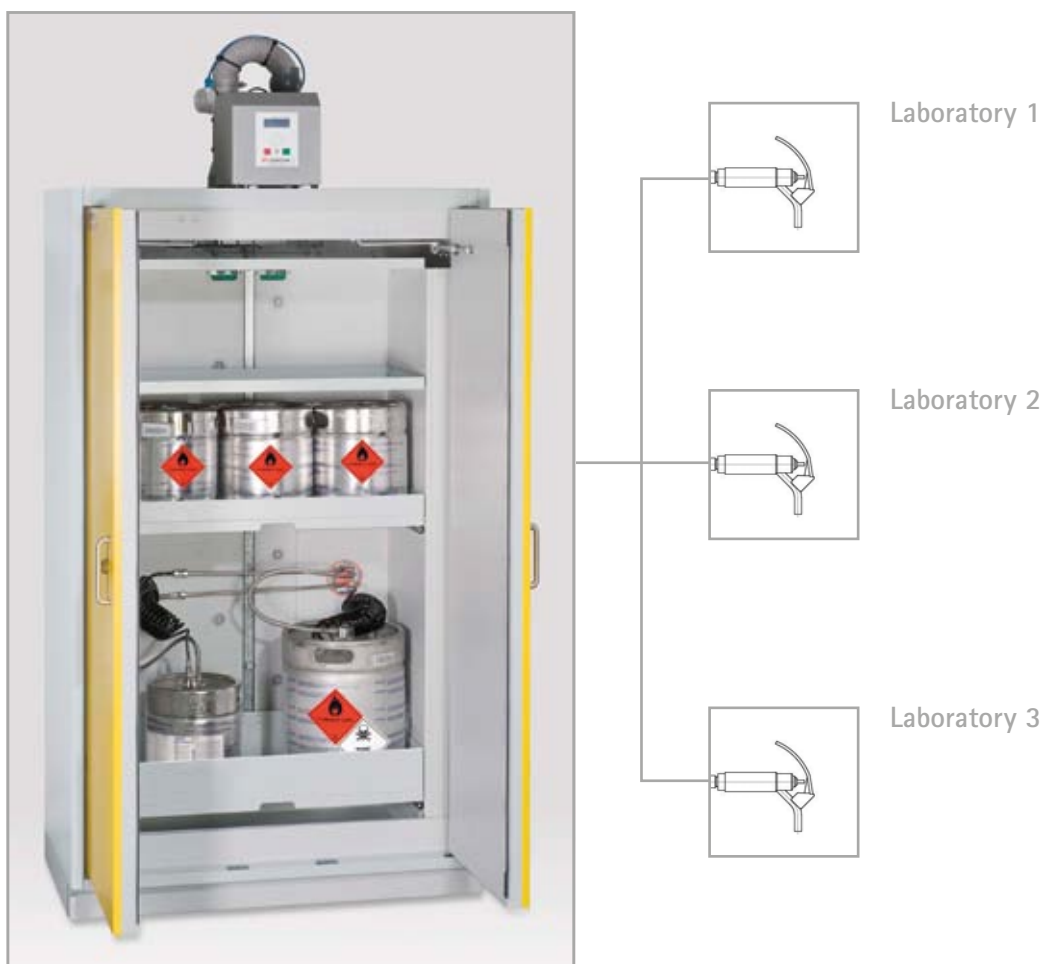

Central supply from one safety cabinet to several laboratories / fume hoods.

Lab Water Purification

Production of ultrapure water suitable for HPLC

The production of ultrapure water from potable tap involves a combination of different purification technologies to efficiently reduce contaminants to minimum levels. Water purification can be divided in two major steps: a pretreatment step, during which 95 to 99% of the contaminants originally present in water are removed, and a so-called polishing step, where the remaining contaminants are removed from the water to deliver ultrapure water.

Schematic of water purification chain that delivers ultrapure water suitable for HPLC use

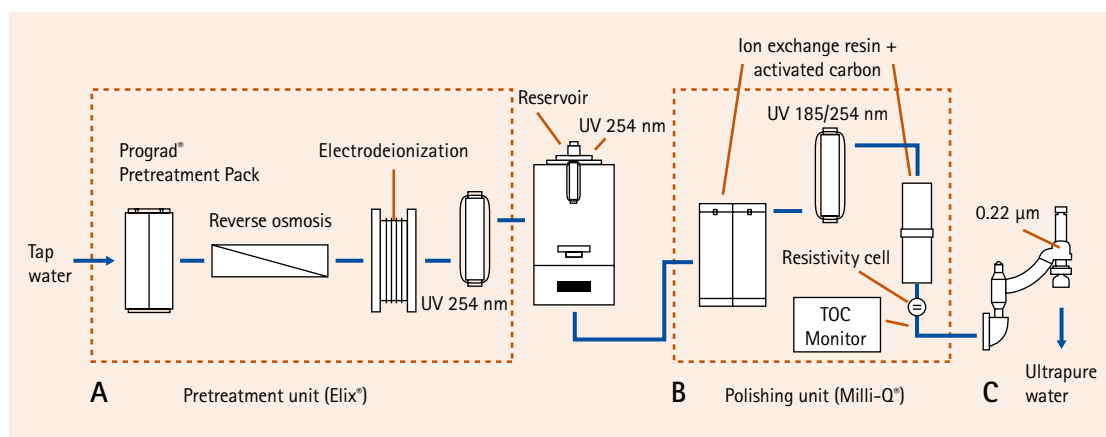

A = Elix® system

B + C = Milli-Q® Advantage system

A + B + C = Milli-Q® Integral system



Benefits of Merck Millipore ultrapure water purification system

- Range of systems with daily production volumes adapted to your needs: from 1 to 300L/ day,
- Ease of pure and ultrapure water dispense, with adjustable flow rate and automatic volume dispense
- Quality exceeding the most stringent norms demand, meeting the requirements of HPLC and UHPLC
- On line Resistivity and TOC monitoring for quality check at the delivery moment
- Full Validation support available to meet easily the cGMP and GLP demands
- Low running cost and water waste thanks to proprietary technologies
- Built-in Millitrack® software for immediate and easy access to data
- Flexible installation: on the bench, wall mounted or bench integrated to save laboratory space

► Contact information:
h2o@merckgroup.com

► Analytical HPLC
page 128

► Preparative HPLC
page 330

1 Pretreatment step – Pure Water Purification Step

The step Pure Water Production removes the bulk of the contaminants originally present in water to produce water with quality superior to double distilled water. It involves three major technologies: **A.** reverse osmosis, **B.** electrodeionization, and **C.** irradiation with germicidal UV.

A. Reverse osmosis [RO]

Reverse osmosis constitutes an excellent first purification step because it has the ability to remove a fair percentage of the major classes of contaminants present in potable tap water. RO will typically remove more than 97% of the ions, more than 99% of organics with molecular weight above 200 Dalton and more than 99% of the colloids, particulates and bacteria. The RO membrane being sensitive to particulates, chlorine and CaCO₃ deposits, an adequate protection is provided by the Progard cartridge located upstream of the RO membrane.

B. Electrodeionization [EDI]

The RO purification step is followed by the Elix® module, an electrodeionization [EDI] patented device combining electrodes, selective anionic and cationic permeable membranes, and ion exchange resins. The ion-exchange resin beads in the EDI module are permanently regenerated by a weak electric current, enabling its operation for several years without any maintenance. The Elix® module is able to remove from the RO permeate most of the remaining inorganic and organic ions.

The combination of RO and EDI is a very powerful pretreatment. It provides Type 2 water on a consistent and reliable basis, with water resistivity typically > 10 MΩ.cm and TOC < 30 ppb (measured in-line).

C. Germicidal UV

A low pressure mercury lamps, emitting light at 254 nm wavelength, placed at the Elix® module outlet, inactivates micro-organisms and prevent bacterial growth and contamination in the pure water produced, just before storage in the reservoir. An optional programmable 254 nm UV lamp in the reservoir maintains low bacterial contamination in the stored pure water and prevents biofilm development.

Polishing step – Ultrapure Water Production Step

2

Pure water momentarily stored in an adequate design reservoir can be used directly for glassware washing process, or further purified for critical chromatography applications. Polishing steps typically combine three purification technologies: **A.** ion-exchange resins, **B.** activated carbon, and **C.** UV photo-oxidation, often followed by the use of a final filter at the point of water delivery, i.e. point-of-use.

A. Ion exchange resins

Ion-exchange resins are small (< 1.2 mm) polystyrene based porous beads with ion-exchange binding sites covalently bound on the surface and inside the beads. Merck Millipore Jetpore® ion-exchange resins are characterized by high-binding capacity, fast ion exchange kinetics to reach high resistivity and low TOC release. The purpose of ion-exchange resins is to remove ions from the water, producing water with an 18.2 MΩ.cm resistivity.

B. Synthetic activated carbon

The synthetic activated carbon is made of porous beads with a large developed surface (> 1000 m²/g) and binds organic molecules on the walls of the pores by Van der Waals forces, π - π or hydrophobic interactions.

C. UV photo-oxidation

A dual-wavelength UV lamp (185 and 254 nm) oxidizes organics dissolved in water, so that they become electrically charged, and are afterwards removed by ion-exchange resins. This technology allows to decrease the organics to a TOC level below 5 ppb.

The combination of the three polishing technologies described above, ion exchange resins, activated carbon, and UV photo-oxidation, yields water with high resistivity (18.2 MΩ.cm) and low TOC level (< 5 ppb).

Point-of-use cartridges

3

Finally, a point-of-use [POU] cartridge is placed at the end of the water purification chain, with two major purposes:

1. removing the contaminants most critical for the experimentation right before water is delivered and used, and
2. prevent retro-contamination of the purification chain from air-borne sources. The final purification cartridge is selected according to the requirements of the instruments or applications used in the laboratory.

Two options are offered for POU cartridges that could be used to produce ultrapure water that is suitable for HPLC, LC-MS, and UHPLC: **A.** 0.22 µm filter and **B.** C18-based cartridge.

A. 0.22 µm screen membrane filter

The 0.22 µm final screen filter retains particles larger than 0.22 µm and bacteria. Merck Millipore membrane filters such as the Millipak filter have been validated for sterilizing filtration and are delivered with a certificate of quality. This 0.22 µm filter is widely used for the production of water for chromatography applications.

B. C18-based cartridge

In rare cases where small contaminant peaks are still present and are a concern, a cartridge packed with C18 particles can be used (LC-Pak).

Elix[®] Advantage system

Tap to Pure Water



Product	Ordering No.
Elix [®] Advantage (3 l/hour), water purification kit, pre-equipped for E-POD unit	ZRXV003WW
Elix [®] Advantage (5 l/hour), water purification kit, pre-equipped for E-POD unit	ZRXV005WW
Elix [®] Advantage (10 l/hour), water purification kit, pre-equipped for E-POD unit	ZRXV010WW
Elix [®] Advantage (15 l/hour), water purification kit, pre-equipped for E-POD unit	ZRXV015WW
E-POD water Delivery Unit dispenser	ZRXSP0D01
E-POD Wall-mounting bracket	WMBQP0D01
POD protection in silicone crystal	PODCOVER01
Footswitch for E-POD dispenser	ZMQSFTS01
Water sensor	ZFWATDET4
30-Liter Polyethylene Pure Water Storage Reservoir	TANKPE030
60-Liter Polyethylene Pure Water Storage Reservoir	TANKPE060
100-Liter Polyethylene Pure Water Storage Reservoir	TANKPE100
200-Liter Storage and Distribution System 200	ZFRE00200
350-Liter Storage and Distribution System 350	ZFRE00350
Automatic Sanitization Module for PE tank	TANKASMIN
Wall-mounting Bracket	WMBSMT002
Lab Close Kit	LABCLOSE1
E-Gard Upgrade Kit	ZRXSUPEG1
Clinical Upgrade Kit	ZRXSUPCL1
UV Upgrade Kit	ZRXSUPUV1

► Analytical HPLC
page 128

► Preparative HPLC
page 330

Milli-Q® Advantage system

Pure to Ultrapure Water

Ordering information – Milli-Q® Advantage system

Product	Ordering No.
Milli-Q® Advantage A10 ultrapure water production unit with built-in resistivity and TOC meter, delivered with UV lamps in place	Z00Q0V0WW
Q-POD ultrapure water delivery unit	ZMQSP0D01
Footswitch for Q-POD (1/pk)	ZMQSFTS01
Cabinet Wall Mounting Bracket	WMBQP0D01
Water sensor	ZFWATDET4
Q-Gard T1 pre-treatment pack	QGARDT1X1
Quantum TEX polishing cartridge	QTUM0TEX1
Millipak® Express 40 0.22 µm final filter	MPGP04001
LC-Pak Reverse Phase Polisher	LCPAK0001



- ▶ Analytical HPLC
page 128
- ▶ Preparative HPLC
page 330

Milli-Q® Integral system

Tap to Pure & Ultrapure Water



Ordering information – Milli-Q® Integral system

Product	Ordering No.
Milli-Q® Integral 3 Pure (3 L/hour) and Ultrapure Water Production Unit with built-in resistivity and TOC meter	ZRXQ003WW
Milli-Q® Integral 5 Pure (5 L/hour) and Ultrapure Water Production Unit with built-in resistivity and TOC meter	ZRXQ005WW
Milli-Q® Integral 10 Pure (10 L/hour) and Ultrapure Water Production Unit with built-in resistivity and TOC meter	ZRXQ010WW
Milli-Q® Integral 15 Pure (15 L/hour) and Ultrapure Water Production Unit with built-in resistivity and TOC meter	ZRXQ015WW
PE Reservoir Designed for optimum storage of pure water (30 L)	TANKPE030
PE Reservoir Designed for optimum storage of pure water (60 L)	TANKPE060
PE Reservoir Designed for optimum storage of pure water (100 L)	TANKPE100
Q-POD ultrapure water delivery unit	ZMQSP0D01
E-POD ultrapure water delivery unit	ZRXSP0D01
Footswitch for Q-PDO and E-POD (1/pk)	ZMQSFTS01
Cabinet Wall Mounting Bracket	WMBSMT002
Q-POD or E-POD Wall Mounting Bracket	WMBQP0D01
Water sensor	ZFWATDET4
ASM (Automatic Sanitization Module) for prevention of biofilm development inside the 30/60/100 L PE reservoir	TANKASMIN
Progard® S2 pre-treatment pack	PROG0T0S2
Quantum TEX polishing cartridge	QTUM0TEX1
Millipak® Express 40 0.22 µm final filter	MPGP04001
LC-Pak Reverse Phase Polisher	LCPAK0001

► Analytical HPLC
page 128

► Preparative HPLC
page 330

LiChropur® reagents for analytical HPLC

Ion pair reagents – what are they?

These are strongly hydrophobic ionic compounds, which form neutral ion pairs with oppositely charged sample molecules. In this way, the simultaneous separation of charged and non-charged molecules is possible. LiChropur® reagents are manufactured to ensure high UV-transmittance even at low detection wavelengths.

What concentrations are recommended?

In practice, a concentration of 5×10^{-3} mol/L has proved suitable for most applications using short-chain ion pair reagents and 5×10^{-4} mol/L for long-chain ion pair reagents.

How can buffers be prepared?

Instructions for preparing buffer solutions with LiChropur® ion pair reagents are included in the product packaging (these instructions may be modified as required by the specific chromatographic method).

Which columns and eluents can be used with these reagents?

They can be used basically with all stationary phases; the eluent should contain at least 10% water as otherwise there is a danger of precipitation (especially if acetonitrile is the organic component).

When using long-chain ion pair reagents such as cetyltrimethylammonium hydrogen sulphate or the sodium salt of dodecanesulfonic acid, the column used for the separation should be reserved for this exclusive purpose as irreversible adsorption can take place on the stationary phase leading to changes in separation behaviour.

Ordering information – Ion pair reagents for analytical HPLC LiChropur®

Product	Ordering No.	Package	Quantity
1-Butanesulfonic acid sodium salt	1.18303.0025	Glass	25 g
1-Pentanesulfonic acid sodium salt	1.18304.0025	Glass	25 g
1-Hexanesulfonic acid sodium salt	1.18305.0025	Glass	25 g
1-Heptanesulfonic acid sodium salt	1.18306.0025	Glass	25 g
1-Octanesulfonic acid sodium salt	1.18307.0025	Glass	25 g
1-Dodecanesulfonic acid sodium salt	1.18308.0025	Glass	25 g
1-Dodecylhydrogensulfate sodium salt	1.18309.0025	Glass	25 g
Tetramethylammonium hydrogen sulfate	1.18310.0025	Glass	25 g
Tetrabutylammonium hydrogen sulfate	1.18312.0025	Glass	25 g
Cetyltrimethylammonium hydrogen sulfate	1.18313.0025	Glass	25 g

Ordering information – Buffer salts for HPLC LiChropur®

Product	Ordering No.	Package	Quantity
di-Potassium hydrogen phosphate trihydrate	1.19754.0250	Glass	250 g
di-Sodium hydrogen phosphate dihydrate	1.19753.0250	Glass	250 g

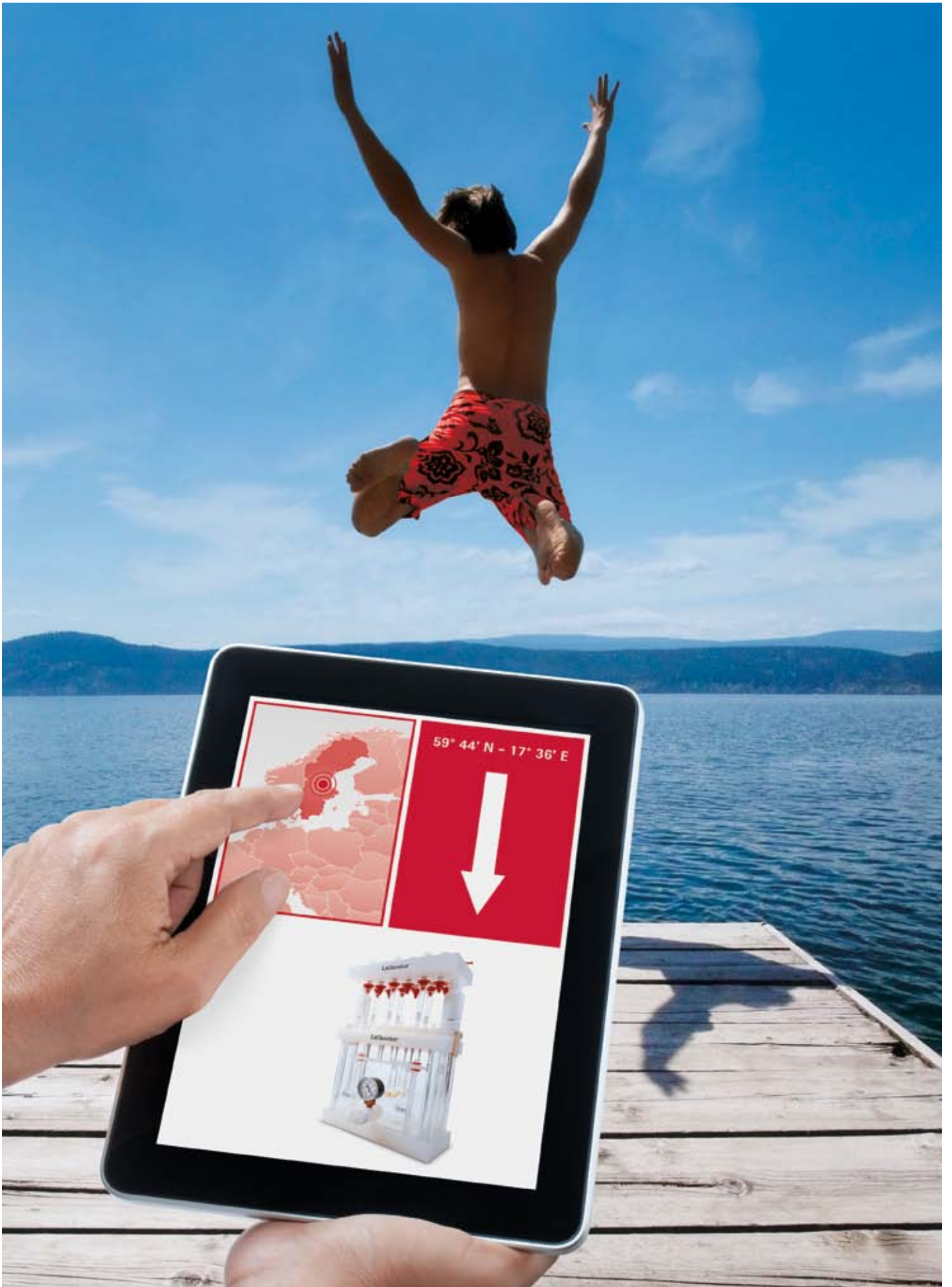

Sample Preparation

We now dive into the field of sample preparation: the essential first step before any analysis. Experts at Merck Millipore are always developing fresh ways to optimize samples for analysis. Products like EXtrelut[®], LiChrolut[®], LiChrospher[®] ADS, Smplicity[™] and Millex[®] can greatly increase analyte detection sensitivity to make analysis as reliable and economical as possible. With our high-quality, innovative products, we support a variety of customers in pharmaceuticals, the food and beverage industry, governmental and academic institutions and many others. One important application of our products is environmental sample preparation. Here they are regularly used to protect our most valuable natural resource: water.

02

Contents

Sample Preparation page 42

EXtrelut® NT working principle page 44
Liquid-liquid extraction in its most effective form

EXtrelut® NT1, EXtrelut® NT3 and EXtrelut® NT20 page 45

EXtrelut® NT refill packs and bulk materials page 46

EXtrelut® NT accessories page 47

Important EXtrelut® NT extraction parameters page 48

LiChrolut® page 50

LiChrolut® selection guide page 51

LiChrolut® page 52
Solid-phase extraction (SPE) with LiChrolut® – the reliable and rapid route to successful sample preparation

LiChrolut® EN page 53
Highest capacity for solid-phase extraction

LiChrolut® extraction unit and drying attachment page 56

LiChrolut® operating principle page 57

LiChrospher® ADS	page 58
LiChrospher® ADS For direct in-line sample preparation of untreated bio-fluids	page 60
LiChrospher® ADS working principle	page 62
Ion exchangers and working principle	page 66
Application guide	page 67
Ion exchangers	page 68
Millex® Syringe Filters Filter with confidence	page 72
Millex® Syringe Filters Sample preparation for chromatography	page 73
Millex® Syringe Filters Sample preparation for UHPLC	page 76
Millex® Syringe Filters Automation-compatible filter	page 80
Samplicity™ Filtration System Break free from routine sample filtration	page 82
Millex Samplicity™ Filters Provide maximum versatility with highest quality.	page 85
Samplicity™ Filtration System Break free from routine sample filtration	page 88

Sample Preparation

Introduction

Thanks to the development of high performance analytical instruments, highly sensitive detectors and advances in the compilation and collation of measurement data, numerous samples can now be analyzed. However, comprehensive control of the most important parameters is necessary to ensure product quality, prevent damage and maintain the quality of columns.

In order to utilize the possibilities offered by chromatographic analysis, samples must be optimally prepared. This is often the most critical step of the analysis, as well as the most time-consuming. Selective and specific sample preparation ensures rational, economical and meaningful analysis.

Advantages of sample preparation:

- Removal of interfering sample components to avoid blocking of HPLC and GC columns
- Selective enrichment of analytes
- Increased concentration of analytes by a factor of 100 to 5,000

Merck Millipore's broad portfolio of sample preparation products can be first classified into off- and on-line methods.

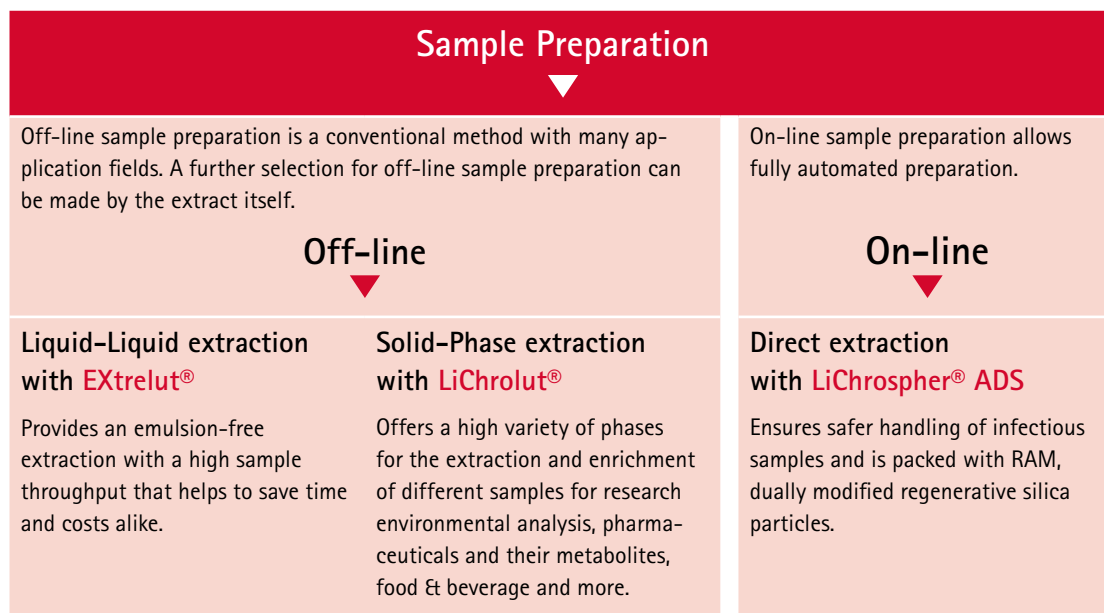

Apart from products for purely mechanical sample preparation procedures, e.g. filtration, we developed the **EXtrelut®** sorbents and columns specially for sample preparation of aqueous matrices; thus we introduced the efficient method of liquid-liquid extraction. With the **LiChrolut®** sorbents and extraction columns for solid-phase extraction, a further efficient alternative to classical extraction using a separating funnel is on offer. **LiChrospher® ADS** represents the third line of products for sample preparation, namely LC-integrated sample preparation, which can help to reduce the needed time for sample preparation dramatically.

An essential component of high quality separation and purification processes, **Millex® Syringe Filters** can be found in virtually every laboratory. The **Samplivity™ Filtration System** is designed to filter up to 8 samples directly into standard HPLC vials.



EXtrelut® NT working principle

Liquid-liquid extraction in its most effective form

EXtrelut® NT simplifies liquid-liquid extraction by replacing separation funnels. Using a single step is more efficient, saves solvent, as well as material and time in contrast to classical funnel separation.

Benefits of EXtrelut® NT

- Saves solvent
- Easy-to-use
- Highly efficient

With its easy-to-use working principle a higher recovery and cleaner extraction can be achieved. The aqueous sample is simply applied to the EXtrelut® NT sorbent. It distributes itself in the form of a thin film over the chemically inert matrix and thus acts as a stationary phase.

Subsequently, elution takes place using organic solvents that are non miscible with water, solvents like e.g. diethyl ether, ethyl acetate or halogenated hydrocarbons. All the lipophilic substances are extracted from the aqueous into the organic phase. During this process the aqueous phase remains on the stationary phase. The eluate is free from emulsions and can be evaporated for further analysis.

Specifications of EXtrelut® NT

Characteristics	Specially processed, wide-pore kieselguhr with a high pore volume Chemically inert Naturally occurring product		
Capacity limit with aqueous sample	EXtrelut® NT1	1 mL	without any breakthrough
	EXtrelut® NT3	3 mL	
	EXtrelut® NT20	20 mL	
pH range	pH 1-10		
Uniform batch-to-batch quality			

Please review also our important extraction parameters.

The working principle of EXtrelut® NT

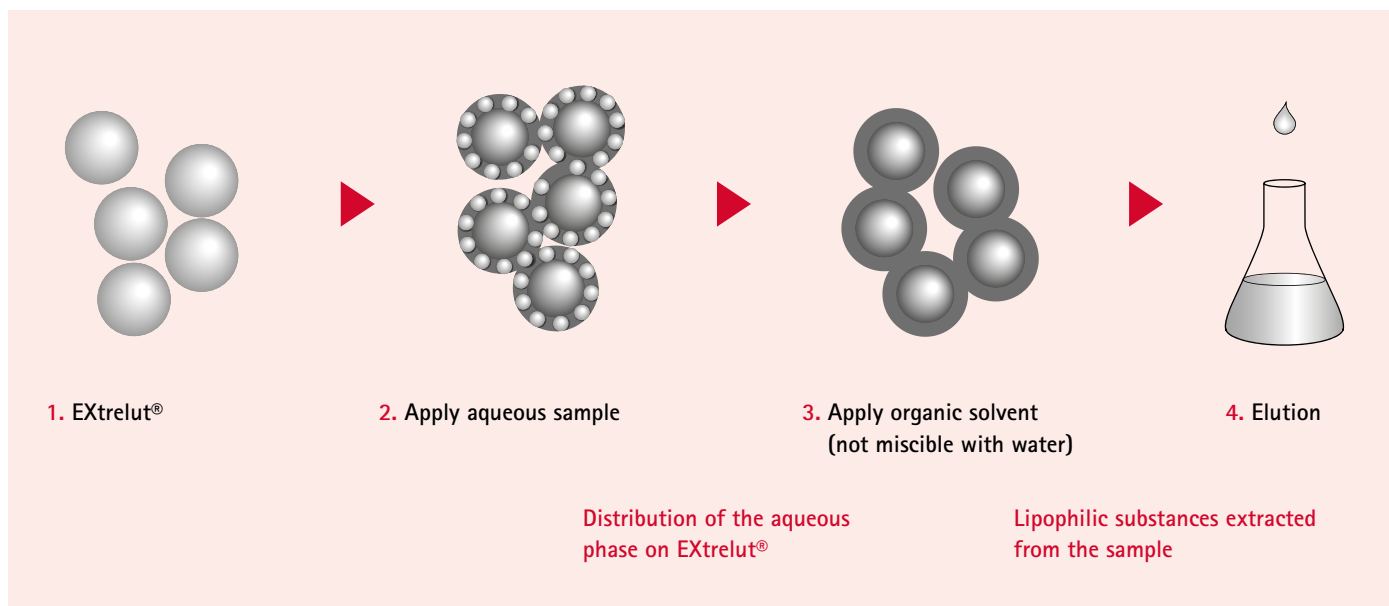

EXtrelut[®] NT1, EXtrelut[®] NT3 and EXtrelut[®] NT20

Classical extraction using a separation funnel is often associated with certain disadvantages: Formation of emulsion, poor phase separation, high solvent consumption, low degree of automation and high personnel costs.

In contrast liquid-liquid extraction is more efficient using EXtrelut[®] NT. The simple and excellent performance of EXtrelut[®] NT eliminates emulsions and therefore higher recoveries and cleaner extracts can be achieved. Therefore EXtrelut[®] NT is available as glass columns. This is particularly recommended if high degrees of purity have to be achieved for subsequent analyses. The column filling is kept between two pure paper filters.

EXtrelut[®] NT20 is a special polyethylene column which avoids contamination of the sample that might otherwise occur when using conventional plastics and plasticizers. This also applies to the special adhesive-free glass fibre and pure paper filters.

Ordering information – EXtrelut[®] NT prepacked columns

Product	Ordering No.	Contents of one package
EXtrelut [®] NT1 glass columns for 0.1 to 1 mL sample solution	1.15094.0001	100 columns
EXtrelut [®] NT3 glass columns for 1 to 3 mL sample solution	1.15095.0001	50 columns
EXtrelut [®] NT20 polyethylene columns including special outlet cannulae for up to 20 mL sample solution	1.15096.0001	25 columns

These products are not intended for use as in-vitro diagnostics in terms of European Directive 98/79/EC. They are for research purposes only, for investigating in-vitro samples derived from the human body without any medical objective.

The capacity of EXtrelut[®] NT prepacked columns for aqueous samples are specified by the designation

EXtrelut [®] NT1	EXtrelut [®] NT3	EXtrelut [®] NT20
can take up a maximum of 1 mL of aqueous sample	can take up a maximum of 3 mL of aqueous sample	can take a maximum of 20 mL of aqueous sample

Significantly smaller samples must be appropriately diluted. If larger volumes are applied, the columns are overloaded; water breaks through into the solvent. Elution is carried out with 2-3 times the sample volume. The liquid may simply be allowed to run through the column. The column outlet cannula regulates the solvent flow appropriately.

EXtrelut® NT refill packs and bulk materials

EXtrelut® NT20 refill packs have an absorption capacity (g of aqueous sample/g EXtrelut® NT support) of the respective EXtrelut® NT batch but with a different weight. These are defined in such a way that at least 20 mL of aqueous sample (+ 10% reserve) can be absorbed. Thus, one complete refill pack should be used for every EXtrelut® NT20 column. The individual packs allow the content to be emptied without any remaining residues. Refill packs also include glass fibre (24 mm) and pure paper filters (10 mm) for the EXtrelut® NT20 columns.

EXtrelut® NT packing material is available in 1 kg quantity. The absorption capacity of this packing material should first be established by carrying out pre-testing of the respective batch since changes in capacity can occur. This is due to different quality of the diatomaceous earth which is a pure natural product. This filling material is ideal for applications which require large volume columns.

Ordering information – EXtrelut® NT packing material

Product	Ordering No.	Contents of one package
EXtrelut® NT bulk packing for preparing large-volume columns	1.15092.1000	1 kg
EXtrelut® NT refill packs for refilling 50 EXtrelut® NT20 columns (incl. replacement filters)	1.15093.0001	50 bags

These products are not intended for use as in-vitro diagnostics in terms of European Directive 98/79/EC. They are for research purposes only, for investigating in-vitro samples derived from the human body without any medical objective.



EXtrelut® NT – liquid-liquid extraction in its most effective form

EXtrelut[®] NT accessories



EXtrelut[®] NT collection tube for EXtrelut[®] NT1 and EXtrelut[®] NT3 glass columns

Ordering information – EXtrelut[®] NT accessories

Product	Ordering No.	Contents of one package
EXtrelut [®] NT accessories cannulae 0.60/30 with Luer tip for EXtrelut [®] NT1 and EXtrelut [®] NT3	1.15373.0001	100 pieces
EXtrelut [®] NT collection tubes with tapered bottom and screw cap (normal capacity 15 mL) for EXtrelut [®] NT1 and EXtrelut [®] NT3	1.15622.0001	30 pieces
Replacement filter for EXtrelut [®] NT1 (10 mm Ø)	1.14236.0001	100 pieces
Replacement filter for EXtrelut [®] NT3 (15 mm Ø)	1.14237.0001	100 pieces
Replacement filter for EXtrelut [®] NT20 (24 mm Ø)	1.14567.0001	50 pieces

Important EXtrelut[®] NT extraction parameters

Important EXtrelut[®] NT extraction parameters

EXtrelut [®] NT [®] extraction columns	Outlet cannulae	Maximum sample volume ¹⁾ [mL]	Waiting period ²⁾ (before elution) [min]	Recommended elution volume ³⁾ [mL]
EXtrelut [®] NT1	0.60 x 30 mm	1	5 – 10	6
EXtrelut [®] NT3	0.60 x 30 mm	3	5 – 10	15
EXtrelut [®] NT20	0.70 x 30 mm	20	10 – 15	40

1. In order to prevent that water breaks through the sample, don't overload the column.
2. Shorter waiting times can affect the recoveries adversely.
3. The recommended sample volumes must be adhered to. Solutions of smaller volumes must be diluted to give indicated volumes.

Application example of EXtrelut[®] NT

EXtrelut[®] NT has been used for quite some time within research, for the sample preparation of urine, whole blood, plasma, serum, gastric juice, liquor, amniotic fluid, faeces, animal and plant tissue. Other applications are in the areas of environmental and residue analysis, e.g. the analysis of industrial, domestic and waste water. The fractionated elution of acidic and basic substances (e.g. drugs and their metabolites) from body fluids is also possible.

Determination of antiepileptic drugs (AEDs) in serum

500 µL serum 500 µL phosphate buffer*	▼	Apply in sequence onto the column
EXtrelut [®] NT1	▼	Wait 8 minutes
1 mL dichloromethane / 2-propanol (9+1)	▼	Wait 10 minutes then elute with
6 mL dichloromethane / 2-propanol (9+1)	▼	Evaporate to dryness under nitrogen stream
Redissolve residue in 1 mL of methanol	▼	
Inject 10 µL into HPLC column		

* 17.6 g NaH₂PO₄, 4.5 g Na₂HPO₄ · 2 H₂O, 1.5 g NaN₃, dissolve in 1 L water (pH 6.0–6.1)

HPLC separation of AEDs after sample preparation with EXtrelut® NT1

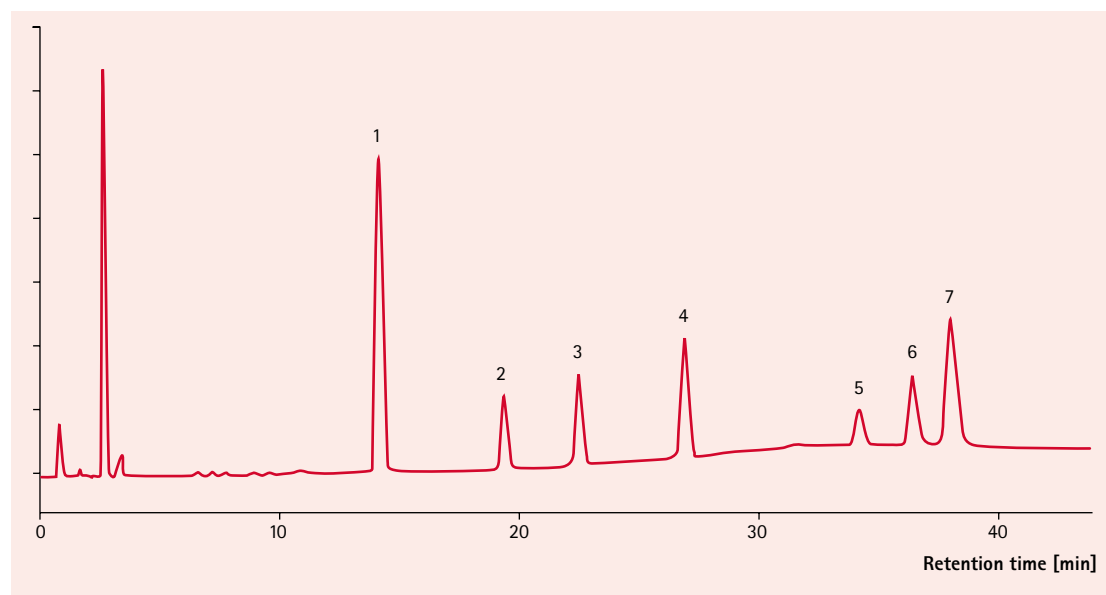

HPLC conditions

HPLC	LaChrom® system		
Column	LiChroCART® 250 x 4 LiChrospher® RP-select B 5 µm Cat. No. 150839		
Mobile phase	A: Water LiChrosolv® [Cat. No. 115333] Acetonitrile LiChrosolv® (1+1) [Cat. No. 100030] B: Water LiChrosolv® [Cat. No. 115333]		
Gradient	Time/min	%A	%B
	0	10	90
	30	60	40
	44	60	40
	44.1	100	0
	50	100	0
	51	10	90
	75	10	90
Flow	1 mL/min		
Temperature	30 °C		
Detection	UV 205 nm		

Recoveries [mean values N = 3]

1	Ethosuximide*	14.1 min	84 ± 7%
2	Primidone	19.4 min	100 ± 2%
3	a-Methyl-a-propylsuccinimide	22.5 min	Internal standard
4	Phenobarbital	26.9 min	96 ± 2%
5	Hexobarbital	34.2 min	99 ± 2%
6	Carbamazepine	36.4 min	97 ± 1%
7	Phenytoin	38.0 min	100 ± 1%

* ethosuximide is volatile on evaporation

Solid-phase extraction (SPE) with LiChrolut® – the reliable and rapid route to successful sample preparation

The primary goal of solid-phase extraction with LiChrolut® is the selective extraction of the components of interest from a complex sample or much larger sample volume prior to actual analysis (e.g. HPLC, GC, TLC). As solid-phase extraction works on the principle of liquid chromatography, this is achieved by using strong but reversible interactions between the analyte and surface of the stationary phase. Typical interactions are e.g. hydrophobic (Van-der-Waals forces), polar (hydrogen bonding, dipole-dipole forces) or ion exchange interactions. Interaction between stationary phase and matrix should not occur.

It is thus meaningful to carry out appropriate sample pretreatment as this emphasizes the differences in chemical properties between the substance to be analyzed and matrix components so that these are then achieved by altering the pH or the ionic strength of the sample solution. Under these conditions, the analyte is enriched as a narrow zone on the stationary phase. Subsequent to a washing step, which serves to remove possible adsorbed sample components, the actual selective elution of the analytes takes place.

Benefits in working with LiChrolut®

- Saves time and solvent
- Higher recoveries without the formation of emulsion.
- High precision of analytical results by use of disposable cartridges.
- Optimized, validated and certified manufacturing with the possibilities for automating the entire process.

Specifications of LiChrolut®

Characteristics	High porosity synthetic silica gel particles
Particle size	40-63 µm
Pore size	60 Å
Specific surface area	~ 600 m ² /g
Stability	pH 2-8
Wide spectra of chemically modified phases	Si 60 high purity, NH ₂ , CN, RP-18e, RP-18, SCX (Strong Cation Exchanger), TSC (Tox Screening Cation)

Specifications of Florisil®

Characteristics	Magnesia-loaded silica gel
Particle size	150-250 µm

► LiChrolut® EN
Highest capacity for
solid-phase extraction
page 53

LiChrolut[®] selection guide

For optimal choice of the extraction method, extensive knowledge of the analyte and sufficient information regarding structure, solubility, polarity and lipophilic properties (distribution coefficients) are necessary. In order to achieve best results you find below our selection guide. It contains information about the typical applications for each LiChrolut[®] product. If you do not find what you are looking for, please review our Analytical Application Finder under www.merck-chemicals.com/aaf or simply contact us.

Application	LiChrolut [®] extraction column	Typical sample matrix	Typical sample substances	Typical elution solvent
Non-polar extraction	RP-18 RP-18e (endcapped) CN	Aqueous buffer solution	Aromatic ring systems, compounds with alkyl chains, aromatic ring systems	Acetonitrile, methanol, ethyl acetate
Polar extraction	Si CN NH ₂	Hexane, oils, chlorinated hydrocarbons	Hydroxyl groups, amines, compounds with hetero atoms (S,N,O)	Methanol, 2-propanol
Cation exchange extraction	SCX (strong)	Methanolic/aqueous buffer with low ionic strength; 2 pH units under pK value of the sample substance	Cations: amines, pyrimidines	Aqueous buffer of high ionic strength (0.1 mol/L); 2 pH units over pK value of the sample substance
Mixed mode extraction	TSC	Body fluids*	Cationic and neutral analytes	Chloroform-acetone, NH ₃ -ethyl-acetate or NH ₃ -methanol
Anion exchange extraction	NH ₂ (weak)	Methanolic/aqueous buffer with low ionic strength; 2 pH units under pK value of the sample substance	Anions: carboxylic acids, sulfonic acids, phosphates	Aqueous buffer of high ionic strength (0.1 mol/L); 2 pH units over pK value of the sample substance
Non-polar extraction on a polymer phase	EN	Drinking, ground and surface water	Polar contaminants: pesticides, phenols, explosives, anilines	Ethyl acetate, methanol, acetonitrile:methanol (1:1)
Non-polar extraction on a polymer phase	EN	Body fluids*	Pharmaceuticals	Acetonitrile, methanol
Medium polar extraction of environmental pollutants	Florisil [®]	Waste/ground/drinking water, soil samples	Herbicides, pesticides, PCBs, PCPs, dioxins, phenols, nitro compounds, HCHs	n-Hexane, dichloromethane

* These products are not intended for use as in-vitro diagnostics in terms of European Directive 98/79/EC. They are for research purposes only, for investigating in-vitro samples derived from the human body without any medical objective.

LiChrolut®

Solid-phase extraction (SPE) with LiChrolut® – the reliable and rapid route to successful sample preparation

Characterization of LiChrolut®

The LiChrolut® sorbents are subject to stringent quality control which begins with the selection of the raw materials. Continuous quality control of the raw material through immediate steps to the final product ensures the user constant batch-to-batch quality. The batch-to-batch reproducibility of LiChrolut® sorbents is ensured by one particular characteristic, the capacity. The capacity, measured in "mg analyte/g sorbent" means that under identical test conditions, the various batches adsorb and desorb the same quantity of analyte. In the case of LiChrolut® RP-phases and LiChrolut® EN this is characterized by the caffeine capacity for hydrophilic substances and by the diisodecylphthalate capacity (DIDP) for lipophilic substances. Capacity determination in the case of LiChrolut® NH₂ is carried out with 4-nitrophenol and benzyldimethyldodecylammonium bromide. The capacity of LiChrolut® SCX is determined with dopamine hydrochloride. The multi-stage purification procedures carried out on LiChrolut® raw materials become particularly valuable when it comes to trace analysis. The proportion of elutable components is negligibly small, which results in more pure extracts. The specially developed, validated and certificated production processes ensure a high degree of purity of the LiChrolut® sorbents. As all stationary phases are monitored with the most sensitive analytical methods, it is ensured that the very narrow set tolerances can be adhered to, thus providing the user with a highly pure material of uniform quality.

Ordering information – LiChrolut®

Product	Ordering No.	Filling amount	Tube size	Contents of one package
LiChrolut® CN (40-63 µm)	1.19698.0001	200 mg	3 mL PP	50 pieces
LiChrolut® CN (40-63 µm)	1.19699.0001	500 mg	3 mL PP	50 pieces
LiChrolut® EN (40-120 µm)	1.19693.0001	200 mg	3 mL PP	30 pieces
LiChrolut® EN (40-120 µm)	1.19870.0001	200 mg	3 mL PP	30 pieces
LiChrolut® EN (40-120 µm)	1.19691.0001	500 mg	6 mL PP	30 pieces
LiChrolut® EN / RP-18 (top)	1.19912.0001	100 / 200 mg	6 mL PP	30 pieces
LiChrolut® EN (40-120 µm)	1.19941.0001	200 mg	6 mL PP	30 pieces
Florisil® (150-250 µm)	1.19127.0001	1,000 mg	6 mL PP	30 pieces
Florisil®	1.19129.0001	500 mg	15 mL-12 cc	50 pieces
LiChrolut® NH ₂ (40-63 µm)	1.19696.0001	200 mg	3 mL PP	50 pieces
LiChrolut® RP-18 (40-63 µm)	1.19855.0001	100 mg	1 mL PP	100 pieces
LiChrolut® RP-18 (40-63 µm)	1.02014.0001	200 mg	3 mL PP	50 pieces
LiChrolut® RP-18 (40-63 µm)	1.02023.0001	500 mg	3 mL PP	50 pieces
LiChrolut® RP-18 (40-63 µm)	1.19687.0001	500 mg	6 mL PP	30 pieces
LiChrolut® RP-18 (40-63 µm)	1.02122.0001	1,000 mg	6 mL PP	30 pieces
LiChrolut® RP-18 (40-63 µm)	1.19686.0001	2,000 mg	6 mL PP	30 pieces
LiChrolut® RP-18e (40-63 µm)	1.19847.0001	200 mg	3 mL PP	50 pieces
LiChrolut® RP-18e (40-63 µm)	1.19849.0001	500 mg	3 mL PP	50 pieces
LiChrolut® SCX (40-63 µm)	1.02016.0001	200 mg	3 mL PP	50 pieces
LiChrolut® SCX (40-63 µm)	1.02022.0001	500 mg	3 mL PP	50 pieces
LiChrolut® Si (40-63 µm)	1.02021.0001	200 mg	3 mL PP	50 pieces
LiChrolut® Si (40-63 µm)	1.02024.0001	500 mg	3 mL PP	50 pieces
LiChrolut® TSC (40-63 µm)	1.19767.0001	300 mg	3 mL PP	50 pieces

These products are not intended for use as in-vitro diagnostics in terms of European Directive 98/79/EC. They are for research purposes only, for investigating in-vitro samples derived from the human body without medical objective.

LiChrolut® EN

Highest capacity for solid-phase extraction

LiChrolut® EN was especially developed for application in environmental analysis where highly contaminated samples occur and very polar organic compounds have to be analyzed. Due to the extremely large specific surface (approximately 1,200 m²/g according to the BET-method) the adsorption capacity for polar organic substances (e.g. triazines, phenylurea compounds, phenoxy-carboxylic acids, phenols, naphthols, aromatic nitro compounds and anilines) is excellent. In comparison to LiChrolut® RP-18, LiChrolut® EN has a tenfold higher capacity. Thus, only 200 mg of sorbent is sufficient for reproducible extractions and high recovery rates.

Benefits in working with LiChrolut® EN

- Use of common organic solvents, buffer solutions, acids and bases over the entire pH-range.
- Saving of solvent, as little solvent is required for conditioning and elution of the cartridge bed.
- Time saving, as less adsorbent requires less time for conditioning and drying.
- Improved analysis, as the reduced quantity of solvent required for elution leads to a lower degree of contamination and to an increase in detection sensitivity.

Specifications of LiChrolut® EN

Sorbent type	Ethyl vinyl benzene divinyl benzene polymer (orange)
Particle shape	Irregular
Particle size distribution	40 - 120 µm
Specific surface	1,200 m ² /g (according to BET)
Pore volume	0.75 mL/g
Stability	pH 1 - 13
Capacity	500 mg Caffeine/g sorbent (model substance for polar analytes) 500 mg Diisodecylphthalate DIDP/g sorbent (model substance for nonpolar analytes)

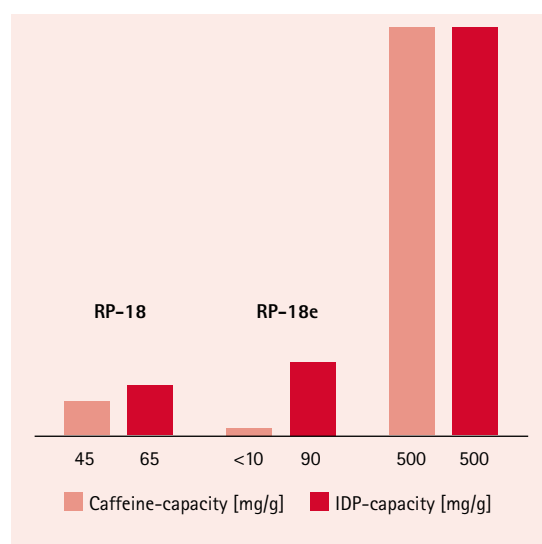

Capacity of LiChrolut® EN

Ensured capacity of LiChrolut® EN in comparison to LiChrolut® RP phases. The increase of sorbent capacity **(by a factor of at least 10)** in comparison to commonly used C-18 sorbent means that only 200 mg of LiChrolut® EN are necessary for the complete enrichment of different contaminants from water.

Ordering information – LiChrolut® EN columns

Product	Ordering No.	Filling amount	Tube size	Contents of one package
LiChrolut® EN (40-120 µm)	1.19693.0001	200 mg	3 mL glass	30 pieces
LiChrolut® EN (40-120 µm)	1.19870.0001	200 mg	3 mL PP	30 pieces
LiChrolut® EN (40-120 µm)	1.19691.0001	500 mg	6 mL PP	30 pieces
LiChrolut® EN (40-120 µm) / LiChrolut® RP-18 (40-63 µm) [top]	1.19912.0001	100 mg / 200 mg	6 mL PP	30 pieces

These products are not intended for use as in-vitro diagnostics in terms of European Directive 98/79/EC. They are for research purposes only, for investigating in-vitro samples derived from the human body without any medical objective.

Ordering information – LiChrolut® EN columns

Product	Ordering No.	Contents of one package
LiChrolut® EN for environmental analysis	1.19853.0020	20 g

Application of LiChrolut® EN – Sample preparation of drinking water samples

Anilines pH 9 with NaOH	Explosives pH 5.5 – 6.0	Solid phase extraction LiChrolut® EN 200 mg, 3 mL	Pesticides pH 5.5 – 6.0	Phenols pH 2 with 25% HCl
3 mL ethyl acetate 3 mL methanol 3 mL water	3 mL methanol 3 mL water	conditioning	3 mL methanol 3 mL water	3 mL ethyl acetate 9 mL water, pH 2
1000 mL sample within 2 h	1000 mL sample within 2 h	sample application	1000 mL sample within 2 h	1000 mL sample within 2 h
1 mL water 1 min with nitrogen	not required not required	wash dry	1 mL water 10 min with nitrogen	1 mL water, pH 2 5 min with nitrogen
2 x 1.5 mL methanol/ acetonitrile/acetone (50/50/1)	2 x 1.5 mL acetonitrile/ methanol (50/50)	elution	2 x 3 mL methanol/ ethyl acetate (50/50)	3 x 0.3 mL ethyl acetate

Typical applications LiChrolut® EN

General remark	Mixed polarity copolymer perfectly suited for: <ul style="list-style-type: none"> • Mixed polar analytes (sorbent provides both polar and non-polar interaction sites) • Trace analysis (extremely high surface area of 1200-1400 m²/g) • Extreme pH conditions (sorbent stability from pH 1-13)
Typical analytes	Environmental pollutants: Fungicides, herbicides, phenols, pesticides, parabens and hydrocarbons Food & beverage: Dyes, essential oils, organic acids, fat/water soluble vitamins, steroids, phthalate esters, surfactants, theophylline. Pharma: Antibiotics, barbiturates, benzodiazepines, caffeine, drugs and their metabolites
Typical matrix	Polar, aqueous buffer, serum, plasma, urine, beverages, environmental samples (waste/drinking water, soil)
Typical eluent	Organic solvent, alcohols, acetonitrile, hexane, methylene chloride, ethyl acetate

Pesticide recovery rates of samples of tap water [N = 10] containing the 33-multicomponent standard [c = 200 ng/L per pesticide]

Pesticide 1. - 17.	Recovery rate ± rsd [%]	Pesticide 18. - 33.	Recovery rate ± rsd [%]
1. Desisopropylatrazine	100 ± 2.7	18. Metobromuron	99 ± 3.2
2. Metamitron	98 ± 1.4	19. Metazachlor	108 ± 5.6
3. Chloridazon	96 ± 1.8	20. Methoprotryne	99 ± 3.8
4. Desethylatrazine	101 ± 2.6	21. Dimefuron	100 ± 1.7
5. Crimidine	86 ± 3.2	22. Sebutylazine	99 ± 1.7
6. Carbetamide	87 ± 3.8	23. Propazine	102 ± 1.9
7. Bromacil	103 ± 3.4	24. Terbutylazine	98 ± 1.5
8. Simazine	99 ± 1.7	25. Linuron	97 ± 1.9
9. Cyanazine	100 ± 1.9	26. Chloroxuron	101 ± 1.1
10. Desethylterbutylazine	95 ± 2.2	27. Prometryne	95 ± 2.3
11. Karbutilate	82 ± 4.7	28. Chlorpropham	101 ± 2.8
12. Methabenzthiazuron	94 ± 2.4	29. Terbutryne	96 ± 1.6
13. Chlortoluron	100 ± 2.5	30. Metolachlor	102 ± 1.5
14. Atrazine	100 ± 3.8	31. Pencycuron	91 ± 2.5
15. Monolinuron	98 ± 1.8	32. Bifenox	102 ± 4.1
16. Isoproturon	101 ± 3.8	33. Pendimethalin	98 ± 5.0
17. Diuron	102 ± 5.0		

LiChrolut® extraction unit and drying attachment

All the individual steps associated with solid-phase extraction can be carried out using the LiChrolut® extraction unit rapidly and reliably. This transparent and vacuum-suitable unit made of glass can be used to prepare up to 12 samples simultaneously.

Your benefits

- Control of the vacuum via a manometer located at the front.
- Individual and easy setting of the various flow rates using valves.
- Glass vessel, lid and standard accessories consist of inert and easily cleaned materials.
- Standard accessories enable various sized collection vessels from volumetric flasks to autosampler vials to be used.



Ordering information – LiChrolut® extraction unit and drying attachment

Product	Ordering No.	Contents of one package
LiChrolut® extraction unit, complete	1.19851.0001	1 lid with 12 standard valves and seal, 1 glass chamber with gauge and vacuum valve, 12 standard stainless steel cannules, 1 collecting rack (base plate with 3 support rods, center plate, top plate with 10 mm boring and 12 clamps), 1 rack for volumetric flasks, 1 rack for test tubes 16 mm, 1 rack for autosampler vials
LiChrolut® drying attachment, complete	1.19852.0001	1 piece
Disposable fluoroplastic liners	1.19874.0001	100 pieces
Large volume capillaries	1.19902.0001	6 pieces stainless steel, electro-polished 2.0 o.d. x 1,5 i.d. x 300 mm lg
PTFE adapter Adapter (PTFE) Luer inlet for solvent reservoir, suitable for LiChrolut® columns of various sizes	1.02206.0001	10 pieces for 119828 and 119878 and all 1 and 3 mL PP SPE columns
Frits (PTFE) for 3 mL glass columns, porosity 10 µm	1.19891.0001	100 pieces

LiChrolut[®] operating principle

Four steps are necessary for solid-phase extraction

These should be optimized in order to obtain maximum recovery.

1. Conditioning the sorbent

In the case of chemically modified silica gels, solvation with an organic solvent (acetonitrile or methanol) is necessary prior to the actual conditioning i.e. the preparation of the sorbent for the sample milieu with water or buffer solution (in order to be accessible for the analyte). This is a pre-requisite for reproducible sorption of the analyte. Excess organic solvent is removed using water or a buffer solution.

2. Application of the sample

The sample solution is forced by vacuum or pressure through the conditioned extraction cartridge. In this process the substance to be analyzed concentrates itself as a narrow zone on the sorbent. In the ideal case no matrix components will be adsorbed and run through the extraction cartridge to waste.

3. Washing

Other interfering matrix components are removed from the surface of the stationary phase with a small volume of water or buffer. A water buffer mixture containing a small quantity of methanol can also be used.

4. Elution of adsorbed analytes

In this final step of solid-phase extraction, the substance to be analyzed is desorbed with a suitable solvent and eluted as a narrow zone. Subsequent to concentration or dilution of the eluate, analysis can follow immediately. The solvent should be so selected that the reaction between analyte and sorbent is weakened and a distribution of the analyte throughout the eluent takes place. Thus, for optimal choice of the solvent, extensive knowledge of the analyte and sufficient information regarding structure, solubility, polarity and lipophilic properties (distribution coefficients) are necessary.

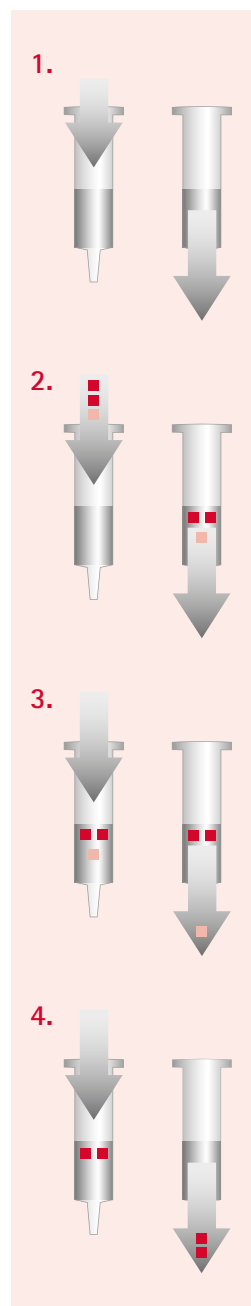

■ Interfering matrix components
■ Substance to be determined

► **LiChrolut[®] selection guide** providing more details on this general principle and more specific information for non-polar, polar and ionic compounds.
page 51

LiChrospher® ADS

LiChrospher® ADS allows the direct extraction and enrichment of hydrophobic, low molecular weight analytes from untreated samples such as haemolysed blood, plasma, serum, milk, salivary fluid, fermentation broth, supernatants of cell cultures and tissue as well as food homogenates.

LiChrospher® ADS sorbents belong to the family of restricted access materials (RAM) with two chemically different surfaces, a hydrophilic external surface and a hydrophobic inner surface. Extraction and fractionation is based on the simultaneous performance of two chromatographic processes: reversed phase/ion-pair chromatography and size exclusion chromatography.

Specifications of LiChrospher® ADS

Sorbent characteristic	Spherical silica gel particles with two chemical different surface modifications	
Surface modifications	1. Exterior surface 2. Interior surface (surface of pores)	DIOL modification C-4, C-8, or C-18 modification
ADS	Alkyl-DIOL-Silica	
Particle size	25 µm	
Pore diameter	60 Å (6 nm)	
Stability	pH 2-7.5	

Analysis with LiChrospher® ADS

The task	<ul style="list-style-type: none">• HPLC analysis of low molecular weight compounds (e.g. drugs, metabolites) in biological samples such as blood, plasma, serum, milk, fermentation broth, supernatants of cell culture or tissue homogenates.• Remove macromolecular compounds (e.g. proteins) prior to HPLC-analysis, as they are irreversibly bound or precipitated.
This leads to	<ul style="list-style-type: none">• Irreversible increase in back pressure• Loss of capacity• Drop in selectivity• Serious damage of HPLC column
The solution	<p>LiChrospher® ADS</p> <ul style="list-style-type: none">• Especially designed as precolumn packing(s) for coupled-column LC-analysis• Outer particle surface is non-adsorptive towards matrix components due to its electroneutral and hydrophilic modification• Inner pore surface is accessible only for low molecular compounds (MW < 15000 Dalton) and retention (extraction, enrichment) is due to classical (conventional) RP-partitioning• Extraction and enrichment can be optimized by using either C-18, C-8 or C-4 modified LiChrospher® ADS

Benefits in working with LiChrospher® ADS compared to conventional "off line" sample preparation

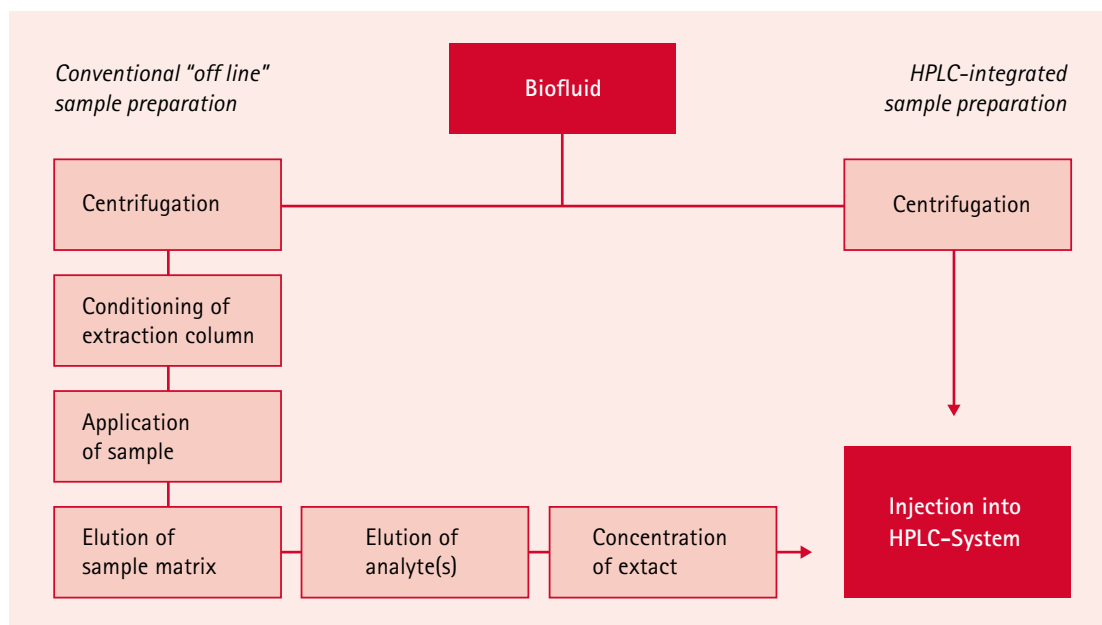

Benefits of LiChrospher® ADS at a glance

- Saves money and time: The high amount of analysis cycles, the direct injection of untreated biological fluids, and the fully automated system, extends column lifetime as well as saving time significantly
- Improved precision, accuracy, and sensitivity
- Quantitative elimination of protein matrix
- On-column enrichment of analytes



*LiChrospher® ADS
for direct on-line sample preparation*

LiChrospher® ADS

For direct on-line sample preparation of untreated bio-fluids

Ordering information – LiChrospher® RP-4 ADS

Product	Ordering No.	Particle size	Dimension length	Dimension i.d.	Contents of one package
LiChrospher® RP-4 ADS	1.50380.0001	25 µm	25 mm	2 mm	1 piece
LiChrospher® RP-4 ADS	1.50381.0001	25 µm	25 mm	2 mm	3 pieces
LiChrospher® RP-4 ADS	1.50208.0001	25 µm	25 mm	4 mm	3 pieces
LiChrospher® RP-4 ADS cartridge set	1.50206.0001	25 µm	25 mm	4 mm	1 LiChroCART® 25-4 LiChrospher® RP-4 ADS 1 manu-CART® holder 25-4

These products are not intended for use as in-vitro diagnostics in terms of European Directive 98/79/EC. They are for research purposes only, for investigating in-vitro samples derived from the human body without any medical objective.

Ordering information – LiChrospher® RP-8 ADS

Product	Ordering No.	Particle size	Dimension length	Dimension i.d.	Contents of one package
LiChrospher® RP-8 ADS	1.50382.0001	25 µm	25 mm	2 mm	1 piece
LiChrospher® RP-8 ADS	1.50209.0001	25 µm	25 mm	4 mm	3 pieces
LiChrospher® RP-8 ADS cartridge set	1.50207.0001	25 µm	25 mm	4 mm	1 LiChroCART® 25-4 LiChrospher® RP-8 ADS 1 manu-CART® holder 25-4

These products are not intended for use as in-vitro diagnostics in terms of European Directive 98/79/EC. They are for research purposes only, for investigating in-vitro samples derived from the human body without any medical objective.

Ordering information – LiChrospher® RP-18 ADS

Product	Ordering No.	Particle size	Dimension length	Dimension i.d.	Contents of one package
LiChrospher® RP-18 ADS	1.50385.0001	25 µm	25 mm	2 mm	1 piece
LiChrospher® RP-18 ADS	1.50386.0001	25 µm	25 mm	2 mm	3 pieces
LiChrospher® RP-18 ADS	1.50947.0001	25 µm	25 mm	4 mm	3 pieces
LiChrospher® RP-18 ADS cartridge set	1.50187.0001	25 µm	25 mm	4 mm	1 LiChroCART® 25-4 LiChrospher® RP-18 ADS 1 manu-CART® holder 25-4

These products are not intended for use as in-vitro diagnostics in terms of European Directive 98/79/EC. They are for research purposes only, for investigating in-vitro samples derived from the human body without any medical objective.

Ordering information – LiChrospher® ADS cartridge kit and accessories

Product	Ordering No.	Particle size	Dimension length	Dimension i.d.	Contents of one package
LiChrospher® ADS cartridge kit	1.50210.0001	25 µm	25 mm	4 mm	1 LiChroCART® 25-4 LiChrospher® RP-4 ADS 1 LiChroCART® 25-4 LiChrospher® RP-8 ADS 1 LiChroCART® 25-4 LiChrospher® RP-18 ADS 1 manu-CART® holder 25-4
LiChrospher® ADS In-line filter (replacement pack)	1.51192.0001	25 µm	-	-	5 pieces
In-line filter holder	1.51193.0001	25 µm	-	-	1 piece
Filter insert In-line	1.51194.0001	2 µm	-	-	10 pieces

These products are not intended for use as in-vitro diagnostics in terms of European Directive 98/79/EC. They are for research purposes only, for investigating in-vitro samples derived from the human body without any medical objective.

Ordering information – LiChrospher® ADS loose sorbents

Product	Ordering No.	Particle size	Filling amount	Packaging
LiChrospher® RP-4 ADS	1.50349.0010	25 µm	10 g	Plastic bottle
LiChrospher® RP-8 ADS	1.50348.0010	25 µm	10 g	Plastic bottle
LiChrospher® RP-18 ADS	1.50347.0010	25 µm	10 g	Plastic bottle

These products are not intended for use as in-vitro diagnostics in terms of European Directive 98/79/EC. They are for research purposes only, for investigating in-vitro samples derived from the human body without any medical objective.

LiChrospher® ADS working principle

Prior to its first use the LiChrospher® ADS precolumn has to be conditioned as follows:

15 mL	2-propanol
15 mL	methanol
15 mL	water

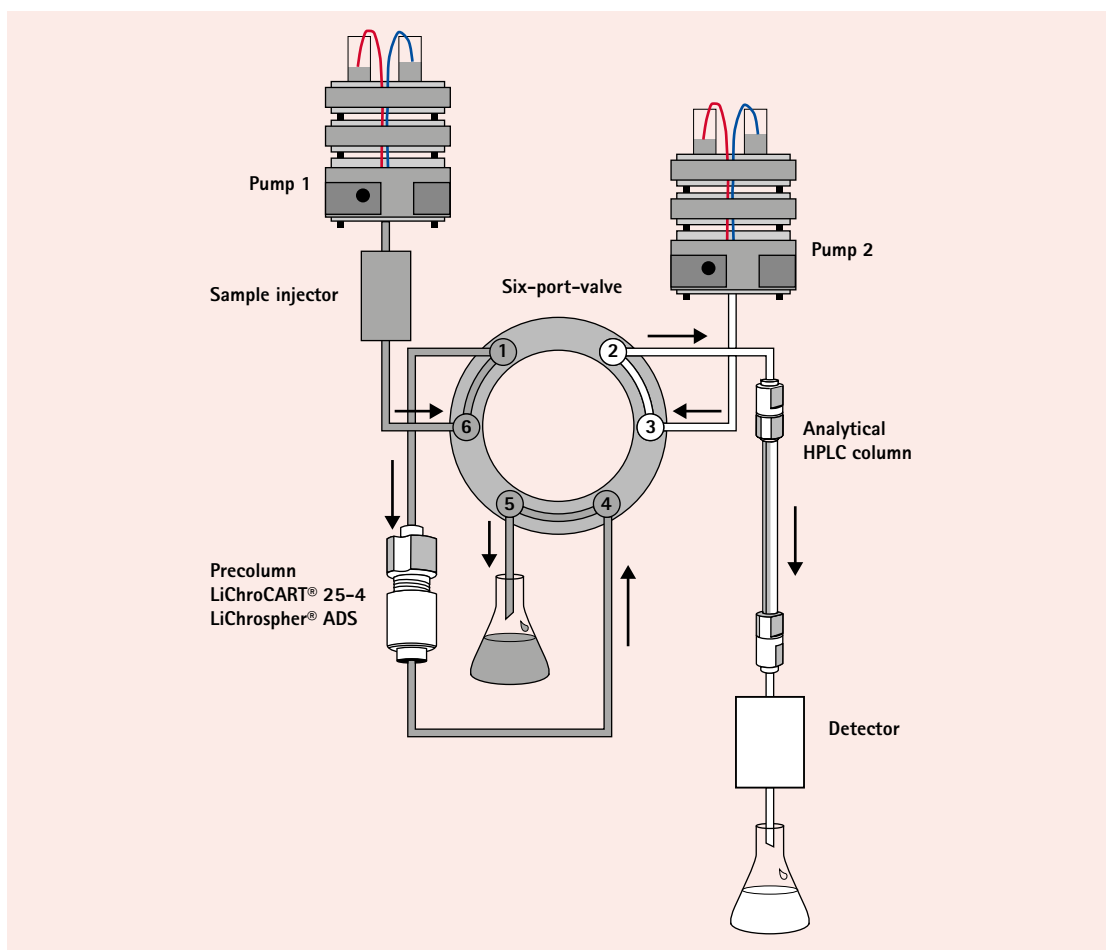

1. Sample injection and fractionation

The sample is injected directly onto the precolumn. In an ideal situation the precolumn packing only retains, i.e. extracts and enriches the analyte(s) while all other sample components (unwanted matrix) are discharged to waste with the eluent delivered by pump 1.

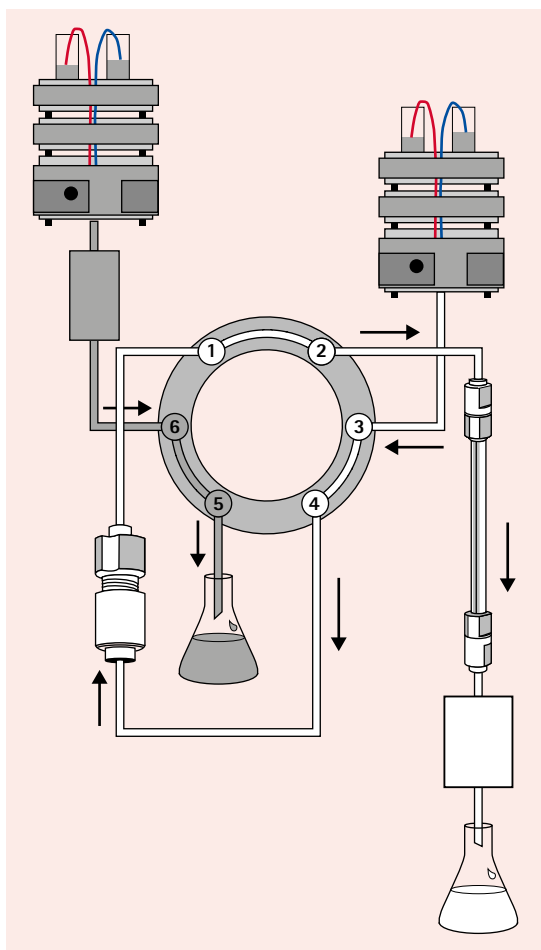

2. Transfer of the analytes

Transfer of the analytes to the analytical column. A conventional, manually or electrically driven six-port valve is used to couple the precolumn and an analytical column in series. An eluent delivered by pump 2 flushes the precolumn under reversal of the flow direction (back-flush peak compression). The stronger elution power of this eluent causes the analyte(s) to be desorbed from the precolumn and to be transferred on top of the analytical column.

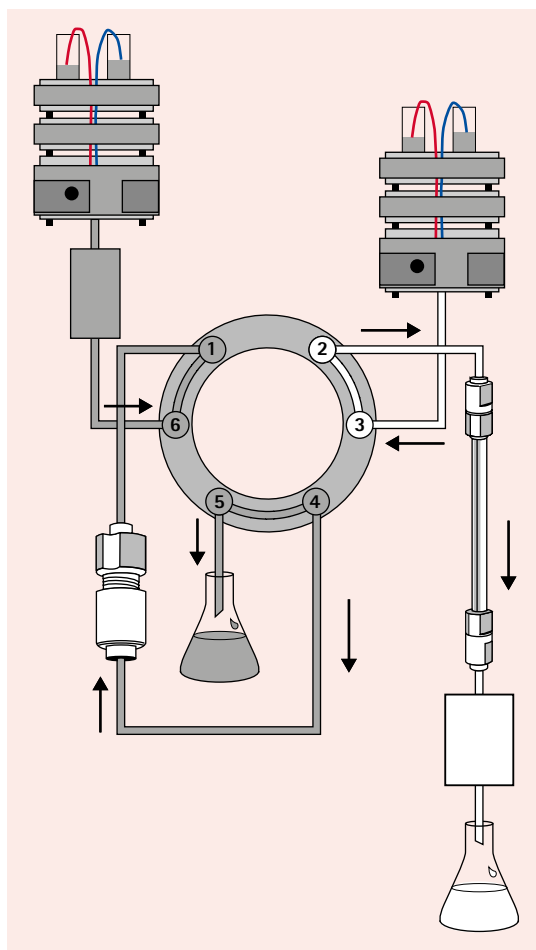

3. HPLC-Separation

After switching back into the original valve position the analytes are separated in a conventional manner. While separation and detection take place, the precolumn is re-equilibrated with the initial eluent to be ready for the next sample injection.

LiChrospher® ADS working principle

Choose the right column

The inner surface of the porous particles exclusively is covered with a hydrophobic dispersion phase (C4, C8, C18 alkyl chains). These adsorption centers are freely accessible for low molecular analytes. Owing to the classical reversed-phase chromatographic properties of LiChrospher® RP ADS these sorbents also can be used for ion-pair chromatography. This means that also charged compounds can be enriched and extracted by adding an appropriate ion-pair reagent (e.g. octanesulfonic acid) to the mobile phase.

Three types of LiChrospher® ADS precolumns are available showing different hydrophobicity, retention, and extraction properties for non polar sample compounds

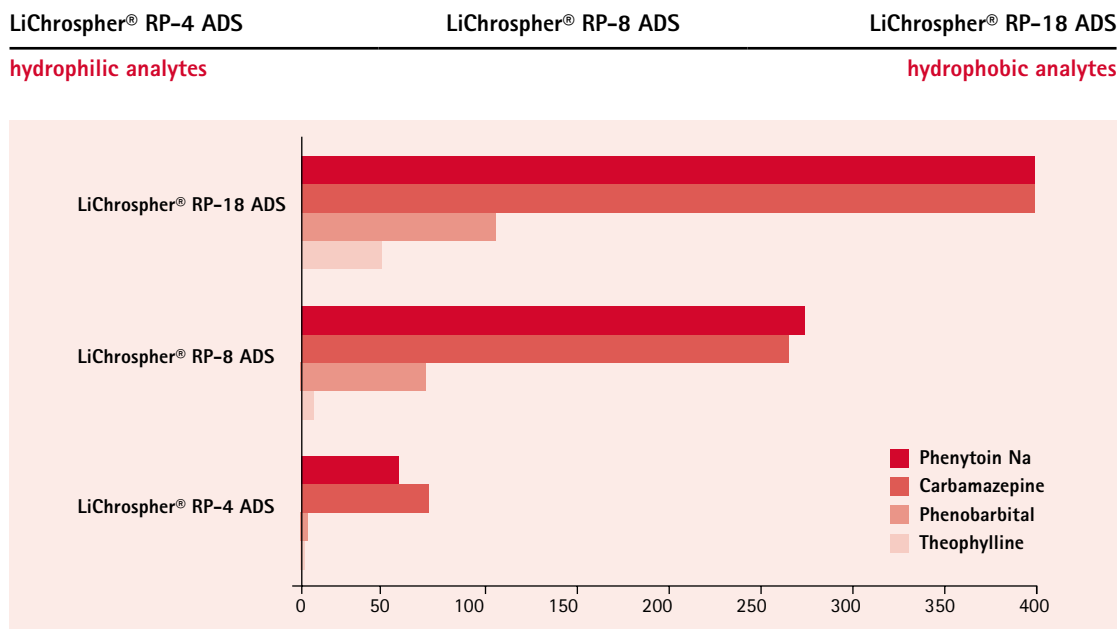

The selection of a LiChrospher® RP ADS precolumn with a low hydrophobicity has a further advantage with respect to the transfer step. E.g. if the sample cleanup is performed using a LiChrospher® RP-8 ADS precolumn and the analyte separation is achieved using a RP-18 column, then it is possible to lower the amount of organic modifier so that the transferred analyte fraction is enriched at the top of the analytical column.

LiChrospher® ADS instrumental set-up

The LiChroCART® 25-4 LiChrospher® ADS precolumn is connected via a 6-port switching valve to a conventional analytical column. The 6-port valve used for column switching has – in contrast to a sample injection valve – no direct sample or syringe inlet but an additional connection between connecting positions 4 - 5 or 5 - 6 subject to a 60 degree rotation. The valve can be operated manually, pneumatically or electrically.

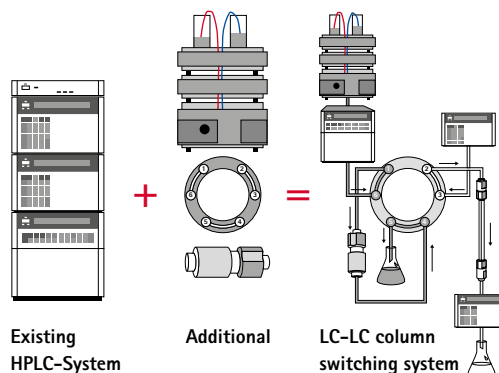

Applications of LiChrospher® ADS

Epirubicin in liver tumor

Precolumn	LiChrospher® RP-4 ADS, 20 x 4 mm i.d.
Analytical column	LiChrospher® 60 RP-select B, 250 x 4 mm i.d.
Flow rate	1 mL/min
Loading	95% water, 5% methanol 10 min
Transfer	30% acetonitrile, 70% water (0.1% TEA, pH 2.0 with TCA) 5 min
Separation	30% acetonitrile, 70% water (0.1% TEA, pH 2.0 with TCA) 10 min
Detection	Fluorescence Ex 445 nm, Em 560 nm
Sample	50 µl
1. Standard: 4'-Epirubicin-HCl	31 ng/mL
2. Supernatant of liver homogenate (protein)	207 mg/mL
3. Supernatant of liver tumor homogenate (protein) after tumor chemoembolization with Lipiodol/4'-Epirubicin-emulsion	1.34 mg/mL

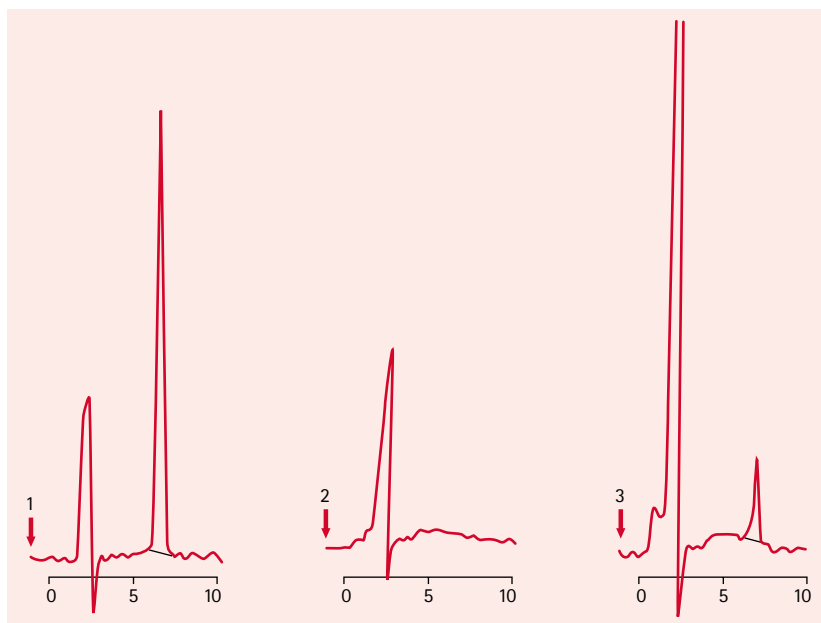

HPLC / Integrated BioDetection of biomarkers in biological samples

On-line coupling of Bioassays to HPLC

Precolumn	LiChrospher® RP-4 ADS, 10 x 2.1 mm i.d.
Analytical column	Chromasil C4, 100 x 2.1 mm i.d.
Mobile phase	Acetonitrile / 20 mM phosphate buffer pH 7.4 (30:70)
Flow rate	0.2 mL/min
Injection volume	500 µl
Label	Biodipy-LTE4
Antibody	Monoclonal anti-LTD4
Reagent flow	0.4 mL/min for both antibody and label
Detection	Fluorescence Ex 544 nm, Em 572 nm
Sample	Sulfidpeptide leukotrienes

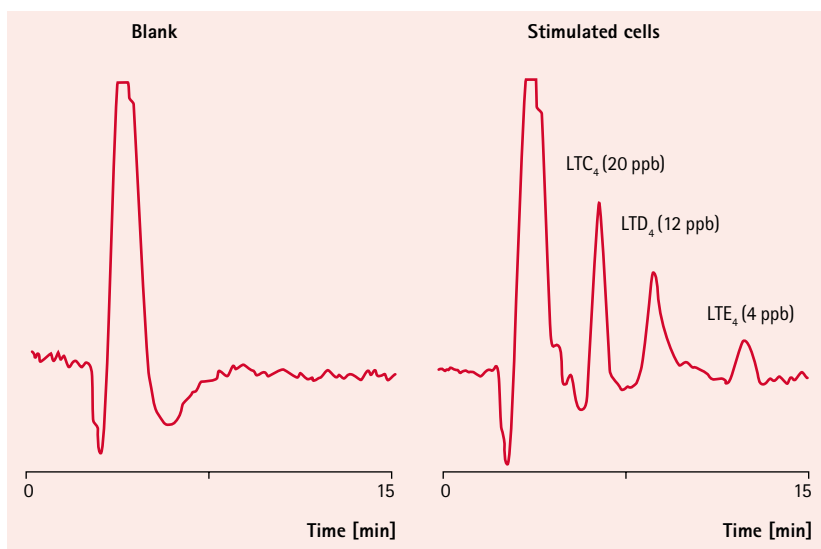

Ion exchangers and working principles

Ion exchangers

All natural and artificial substances which are capable of exchanging bounded ions for an equivalent amount of other ions from a surrounding solution are called ion exchangers.

In general, ion-exchangers consist of a cross-linked polymer matrix with a uniform distribution of fixed ionic sites throughout the resin structure. These must be balanced by a similar number of ions of the opposite charge, the counter ions, to maintain electrical neutrality. Cation exchangers therefore exchange and enrich only cations, anion exchangers only anions. In contrast adsorber resins have a non-ionic, but depending on the structure a somewhat polar character and don't adsorb stoichiometrically both: anions, cations, as well as uncharged compounds.

In essence, four types of ion exchanger can be distinguished:

- Gel ion exchangers
- Macroporous ion exchangers
- Fluid ion exchangers
- Adsorber resins

Ion exchangers have many different applications and therefore find many usages. The most commonly used application methods are the batch process and the column method.

Possible applications are:

- Trace enrichment by using chelating ion exchangers
- Determination of total salt content of solutions and water by H⁺ exchange
- Removal of interfering cations or anions
- Chromatographic separation
- Digestion of insoluble compounds
- Application as a catalyst

The two most commonly used working principles: batch and column method

Batch method

When the batch method is used the solution is shaken together with the according ion exchanger until the balance between the different ions is reached.

This method has many advantages when reactions have to be performed in closed systems where adding further ion exchange material is not possible due to technical reasons. This method also finds its usage whenever a catalytically effect is desired.

Column method

Within the technique as well as within the analytic often a different effect is desired. Usually a complete exchange of ions is needed at best possible utilization of reagent. For this purpose the column method is convenient. Within this method a wished treated solution runs through a column which is packed with the needed exchange material. Washing the packed exchange material within the column in between the steps is essential to remove a surplus of reagent solution within.

Working cycle of the exchangers for the column method:

- Exchange of ions
- Washing of the packing
- Regeneration or elution

The exchange of ions itself can be carried out differently, always according to the existing problem and the specifically needed application.

Application guide

Ion exchanger	Typical application
Strong acid cation exchanger	<ul style="list-style-type: none">• Water treatment• Separation of noble earths• Separation of amino acids• Used in the analysis and food industry
Weak acid cation exchanger	<ul style="list-style-type: none">• Purification and production of antibiotics, vitamins and alkaloids• Purification of enzymes
Strong basic anion exchanger	<ul style="list-style-type: none">• Water treatment• Acidimetric determination of aqueous salt solutions• Purification of complex isolation and determination of alkalis• Determination of pectin in fruit juices• Removal of interfering anions• Catalysis• Deionization of water• Purification of formaldehyde• Separation of amino acids
Weak basic anion exchanger	<ul style="list-style-type: none">• Separation from strong acids• Adsorption of basic dyes in an alkaline medium• Deionization of process solutions• Deacidification of non-aqueous solutions• Desalination of water
Mixed-bed ion exchangers	<ul style="list-style-type: none">• Demineralisation of water
Adsorber resins	<ul style="list-style-type: none">• Separation of surface-active agents such as detergents, emulsifiers and dispersants• Removal of phenol• Isolation of vitamins and antibiotics

Please be aware that this is only a selection of typical application areas. In order to distinguish the ion exchanger needed for your specific application, please also visit our internet under www.merck-chemicals.com/chromatography where you find more information.

Ion exchangers

The following pages show general information about ion exchangers available at Merck Millipore. If you are interested in additional information please visit www.merck-chemicals.com/ionexchangers

Strongly acid cation exchangers

The bond strength of equivalent ions increases with decreasing diameter of the hydrated ion.

This leads to following selectivity series:

$\text{Li}^+ < \text{H}^+ < \text{Na}^+ < \text{NH}_4^+ < \text{K}^+ < \text{Rb}^+ < \text{Cs}^+ < \text{Ag}^+$

$\text{Be}^{2+} < \text{Mg}^{2+} < \text{Ca}^{2+} < \text{Sr}^{2+} < \text{Ba}^{2+}$

$\text{Hg}^{2+} < \text{Be}^{2+} < \text{Mn}^{2+} < \text{Mg}^{2+} = \text{Zn}^{2+} < \text{Co}^{2+} < \text{Cd}^{2+} < \text{Cu}^{2+} < \text{Ni}^{2+} < \text{Ca}^{2+} < \text{Pb}^{2+}$

$\text{Cr}^{3+} < \text{Ce}^{3+} < \text{La}^{3+}$

Specifications of strongly acid cation exchangers

Max. working temperature	120°C		
pH range	0-14		
Regenerant	HCl	H ₂ SO ₄	NaCl
Concentration in water [%]	5-10	2-4	8-10

Ordering information – Strongly acid cation exchangers

Product	Ordering No.	Form	Size	Exchange capacity [mval/mL]
Ionexchanger I	1.04765.0500	H ⁺	500 g	> 1.7
Ionexchanger I	1.04765.5000	H ⁺	5 kg	> 1.7
Amberlite® IR-120	1.15131.0500	H ⁺	500 mL	> 1.7
Amberlite® IR-120	1.15131.5000	H ⁺	5 L	> 1.7
Amberlite® IR-120	1.15966.0500	Na ⁺	500 mL	> 1.9
Amberlyst® 15	1.15635.0500	H ⁺	500 mL	> 1.75
Dowex® 50 WX 8	1.05221.0250	H ⁺	250 g	> 1.7
Dowex® 50 WX 4	1.05238.0250	H ⁺	250 g	> 1.1
Dowex® HCR-W 2	1.05241.0500	H ⁺	500 g	> 1.8

Weak acid cation exchangers

The most important feature weak acid cation exchangers show is the very high selectivity in relation to H⁺ ions. Also they have a relatively high affinity for alkaline earth metal ions.

General: $\text{Na}^+ < \text{Mg}^{2+} < \text{Ca}^{2+} < \text{H}^+$

At pH level 7: $\text{Mg}^{2+} < \text{Ca}^{2+} < \text{Ni}^{2+} < \text{Co}^{2+} < \text{Cu}^{2+}$

Specifications of weak acid cation exchangers

Max. working temperature	120°C	
pH range	4-14	
Regenerant	HCl	H ₂ SO ₄
Concentration in water [%]	2-3	0.5-1

Ordering information – Weak acid cation exchangers

Product	Ordering No.	Form	Size	Exchange capacity [mval/mL]
Ionexchanger IV	1.04835.0500	H ⁺	500 g	> 3.2
Ionexchanger IV	1.04835.5000	H ⁺	5 kg	> 3.2

Ordering information – Chelateexchanger

Product	Ordering No.	Form	Size	Exchange capacity [mval/mL]
Chelex® 100	1.01767.0500	Na ⁺	500 g	> 0.3

Strong basic anion exchangers

An example for the binding strength of strong basic anion exchangers for Type I is as followed:

$F^- < OH^- < \text{Acetate} < H_2PO_4^- < HCO_3^- < Cl^- < NO_2^- < HSO_3^- < CN^- < Br^- < NO_3^- < HSO_4^- < I^- < SO_4^{2-}$
 $\text{Acetate} < \text{Formate} < \text{Tartrate} < \text{Citrate}$

For strong basic anion exchanger of Type II occurs a slight shift in accordance with the following selectivity series:

$F^- < OH^- < \text{Acetate} < IO_3^- < H_2PO_4^- < HCO_3^- < OH^- < BrO_3^- < Cl^- < CN^- = NO_2^- < Br^- = CF_3COO^- < CCl_3COO^- < SCN^-$
 $< HSO_4^- < I^- < ClO_4^-$

Specifications of strong basic anion exchangers

pH range	0-14	
Regenerant	NaCl	NaOH
Concentration in water [%]	8-10	2-4

Ordering information – Strong basic anion exchangers

Product	Ordering No.	Form	Size	Exchange capacity [mval/mL]
Ionexchanger III	1.04767.0500	OH ⁻	500 g	> 0.9
Ionexchanger III	1.04767.5000	OH ⁻	5 kg	> 0.9
Amberlite® IRA-402	1.12463.0500	Cl ⁻	500 mL	> 0.9
Amberlite® IRA-410	1.15262.0500	Cl ⁻	500 mL	> 1.35
Amberjet® 4200 CL	1.05245.0500	Cl ⁻	500 mL	> 1.3
Dowex® 1-X8	1.05242.0250	Cl ⁻	250 mL	> 1.2

Weak basic anion exchangers

The binding strength order of weak basic anion exchangers is as following:

$F^- < Cl^- < Br^- < I^- < \text{Acetate} < MoO_4^{2-} < PO_4^{3-} < AsO_4^{3-} < NO_3^- < \text{Tartrate} < \text{Citrate} < CrO_4^{2-} < SO_4^{2-} < OH^-$

Ordering information – Weak acid cation exchangers

Product	Ordering No.	Form	Size	Exchange capacity [mval/mL]
Amberlite® IRA-67	1.15959.0500	OH ⁻	500 g	> 1.5
Amberlyst® A 21	1.15261.0500	OH ⁻	500 mL	> 1.0

Mixed bed exchangers

This mixed bed exchangers are mixtures of strong acid cation exchangers and strongly basic anion exchanger. They are mainly used in the demineralisation of water, working within a pH value of 0-14.

Ordering information – Mixed bed exchangers

Product	Ordering No.	Form	Size	Anion exchange capacity [mval/mL]	Cation exchange capacity [mval/mL]
Ionexchanger V	1.04836.0500	H ⁺ / OH ⁻	500 g	> 0.4	> 0.5
Ionexchanger V	1.04836.5000	H ⁺ / OH ⁻	5 kg	> 0.4	> 0.5
Amberlite® MB-3	1.15127.0500	H ⁺ / OH ⁻	500 mL	> 0.6	> 0.5
Amberlite® MB-3	1.15127.5000	H ⁺ / OH ⁻	5 L	> 0.6	> 0.5
Amberlite® IRN-150	1.15965.0500	H ⁺ / OH ⁻	500 mL	> 0.6	> 0.7
Amberlite® MB-6113	1.15165.0500	H ⁺ / OH ⁻	500 g	> 0.6	> 0.5

Adsorber resin

The adsorbent resins are synthetic, mechanically stable, insoluble polystyrene divinyl-benzene polymerical, which are characterized by a macroreticular structure and a non-ionic character. In comparison to ion exchangers they show no shrinking or swelling.

Ordering information – Adsorber resin

Product	Ordering No.	Size
Amberlite® XAD-4	1.15256.0500	500 mL
Amberlite® XAD-7	1.15257.0500	500 mL

Millex® Syringe Filters

Filter with confidence

Merck Millipore has a long history of enabling efficient sample preparation within the life science, environmental monitoring, clinical and industrial quality control markets. We constantly strive to advance sample preparation methods and help scientists meet the demands of lower detection limits and increased sample throughput.

An essential component of high quality separation and purification processes, Millex® Syringe Filters can be found in virtually every laboratory. The unsurpassed quality and consistency of results they provide has led to the creation of many sample preparation methods specifying Millex® filters. Global availability allows these methods to be easily transferred to any laboratory, anywhere in the world.



13 mm Millex® filters have high density polyethylene or polypropylene housings and a male Luer slip outlet or MLS outlet with extension tube.



33 mm filters have polypropylene housings with a male Luer slip outlet.

Millex[®] Syringe Filters

Sample preparation for chromatography

Applications

- High performance liquid chromatography (HPLC)
- Ultra high performance liquid chromatography (UHPLC)
- Ion chromatography (IC)
- Gas chromatography (GC)
- Dissolution testing
- General particulate removal

Membranes

- **LCR (hydrophilic PTFE):** Aqueous or mild organic solutions; low binding and extractables
- **Durapore[®] (PVDF):** Aqueous or mild organic solutions; low binding and extractables
- **Nylon:** Aqueous or organic solutions
- **Millipore Express[®] (PES):** Fast flow and low protein binding
- **Fluoropore[™] (hydrophobic PTFE):** Organic solvents

Housings

- High density polyethylene or polypropylene



Choosing the appropriate Millex[®] filter size

Process volume	Millex [®] filter diameter
< 1 mL	4 mm
1 – 10 mL	13 mm
10 – 100 mL	25 mm
10 – 100 mL	33 mm

Low extractables

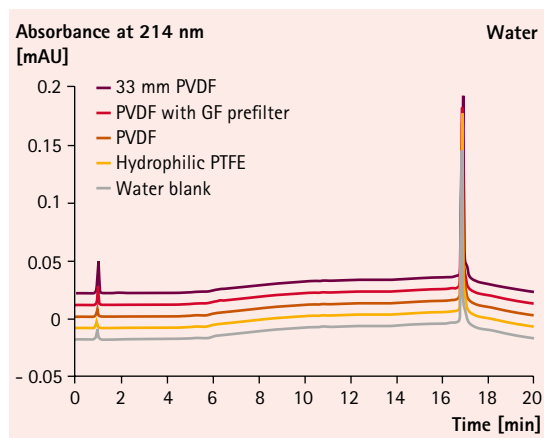

Low water extractables indicate that Millex[®] filters are ideal for dissolution studies and other aqueous-based sample prep protocols.

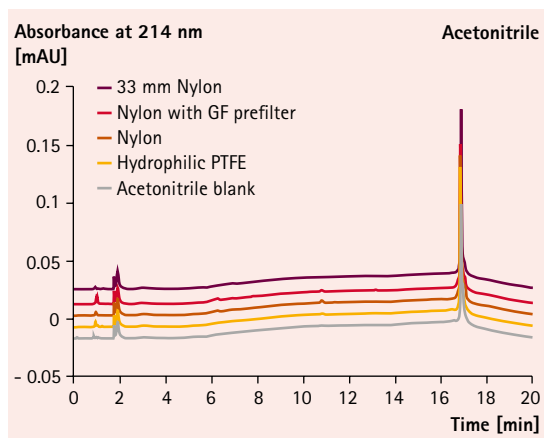

Low extractables are also observed with organic solvents.

► For further information please have a look at our website: www.millipore.com/filtration

Millex® Syringe Filters | Sample preparation for chromatography

Ordering information – Millex® Syringe Filters, 4 mm diameter

Product	Ordering No.	Content / Packaging	Outlet connection	Pore size	Type	Process volume	Hold-up volume [after air purge]
Millex® LCR (Hydrophilic PTFE) Membrane	SLLGR04NL	100	Male stepped	0.20 µm	LG	1 mL	< 10 µL
	SLLHR04NL	100	Male stepped	0.45 µm	LH	1 mL	< 10 µL
	SLLHR04NK	1000					
Durapore® (PVDF) Membrane	SLGVR04NL	100	Male stepped	0.22 µm	GV	1 mL	< 10 µL
	SLGVR04NK	1000					
	SLHVR04NL	100	Male stepped	0.45 µm	HV	1 mL	< 10 µL
	SLHVR04NK	1000					
Fluoropore™ (Hydrophobic PTFE) Membrane	SLFGR04NL	100	Male stepped	0.20 µm	FG	1 mL	< 10 µL
	SLFHR04NL	100	Male stepped	0.45 µm	FH	1 mL	< 10 µL

Ordering information – Millex® Syringe Filters, 13 mm diameter

Product	Ordering No.	Content / Packaging	Outlet connection	Pore size	Type	Process volume	Hold-up volume [after air purge]
Millex® LCR (Hydrophilic PTFE) Membrane	SLLGH13NL	100	Male Luer slip	0.20 µm	LG	10 mL	< 25 µL
	SLLGH13NK	1000					
	SLCR013NL	100	Male Luer slip	0.45 µm	LCR	10 mL	< 25 µL
	SLCR013NK	1000					
	SLCRT13NL	100	Tube outlet				
Durapore® (PVDF) Membrane	SLGVX13NL	100	Male Luer slip	0.22 µm	GV	10 mL	< 25 µL
	SLGVX13NK	1000					
	SLGVX13TL	100	Tube outlet				
	SLHVX13NL	100	Male Luer slip	0.45 µm	HV	10 mL	< 25 µL
	SLHVX13NK	1000					
	SLHVX13TL	100	Tube outlet				
Nylon Membrane	SLGNX13NL	100	Male Luer slip	0.20 µm	GN	10 mL	< 25 µL
	SLGNX13NK	1000					
	SLGNX13TL	100	Tube outlet				
	SLHNX13NL	100	Male Luer slip	0.45 µm	HN	10 mL	< 25 µL
	SLHNX13NK	1000					
	SLHNX13TL	100	Tube outlet				
IC Millex® Filters (Hydrophilic PTFE) Membrane	SLLGC13NL	100	Male Luer slip	0.20 µm	IC Millex®-LG	10 mL	< 10 µL
	SLLHC13NL	100	Male Luer slip	0.45 µm	IC Millex®-LH	10 mL	< 10 µL
Fluoropore™ (Hydrophobic PTFE) Membrane	SLFGX13NL	100	Male Luer slip	0.20 µm	FG	10 mL	< 25 µL
	SLFGX13NK	1000					
	SLFGX13TL	100	Tube outlet				
	SLFHX13NL	100	Male Luer slip	0.45 µm	FH	10 mL	< 25 µL
	SLFHX13NK	1000					
	SLFHX13TL	100	Tube outlet				

Millex® Syringe Filters | Sample preparation for chromatography

Ordering information – Millex® Syringe Filters, 25 mm diameter

Product	Ordering No.	Content / Packaging	Outlet connection	Pore size	Type	Process volume	Hold-up volume [after air purge]
Millex® LCR (Hydrophilic PTFE) Membrane	SLLGH25NS	50	Male Luer slip	0.20 µm	LCR	100 mL	< 100 µL
	SLLGH25NB	250					
	SLLGH25NK	1000					
	SLCR025NS	50	Male Luer slip	0.45 µm	LCR	100 mL	< 100 µL
	SLCR025NB	250					
	SLCR025NK	1000					
IC Millex® Filters (Hydrophilic PTFE) Membrane	SLLGC25NS	50	Male Luer slip	0.20 µm	IC Millex®-LG	100 mL	< 100 µL
	SLLHC25NS	50	Male Luer slip	0.45 µm	IC Millex®-LH	100 mL	< 100 µL
Fluoropore™ (Hydrophobic PTFE) Membrane	SLFG025NS	50	Male Luer slip	0.20 µm	FG	100 mL	< 100 µL
	SLFG025NB	250					
	SLFG025NK	1000					
	SLFH025NS	50	Male Luer slip	0.45 µm	FH	100 mL	< 100 µL
	SLFH025NB	250					
	SLFH025NK	1000					
	SLLS025NS	50	Male Luer slip	5.0 µm	LS	100 mL	< 100 µL

Ordering information – Millex® Syringe Filters, 33 mm diameter

Product	Ordering No.	Content / Packaging	Outlet connection	Pore size	Type	Process volume	Hold-up volume [after air purge]
Durapore® (PVDF) Membrane	SLGV033NS	50	Male Luer slip	0.22 µm	GV	100 µL	≤ 80 µL
	SLGV033NB	250					
	SLGV033NK	1000					
	SLHV033NS	50	Male Luer slip	0.45 µm	HV	100 µL	≤ 80 µL
	SLHV033NB	250					
	SLHV033NK	1000					
Nylon Membrane	SLGN033NS	50	Male Luer slip	0.20 µm	GN	100 mL	≤ 80 µL
	SLGN033NB	250					
	SLGN033NK	1000					
	SLHN033NS	50	Male Luer slip	0.45 µm	HN	100 µL	≤ 80 µL
	SLHN033NB	250					
	SLHN033NK	1000					
Millipore Express® (PES) Membrane	SLGP033NS	50	Male Luer slip	0.22 µm	GP	200 mL	≤ 80 µL
	SLGP033NB	250					
	SLGP033NK	1000					
	SLHP033NS	50	Male Luer slip	0.45 µm	HP	100 µL	≤ 80 µL
	SLHP033NB	250					
	SLHP033NK	1000					

Millex[®] Syringe Filters

Sample preparation for UHPLC

UHPLC/UPLC[®] is a revolutionary chromatography technique using columns packed with very small (sub-2 μm) particles.

This technology provides

- Improved resolution
- Shorter chromatographic runs
- Fast method development
- 3-10 fold decrease in reagent use/disposal costs

However, the small size of the particles used to pack UHPLC columns means that very high pressures are required to operate UHPLC instruments, posing challenges in sample and mobile phase preparation. Any impurities can create backpressure buildup in the UHPLC system, causing system failure.



Membrane filtration removes contaminating particles from samples, solvents and mobile phases, increasing column life, minimizing backpressure, and preventing system failure. That's why most UHPLC instrument manufacturers, recommend filtration of mobile phases using 0.2 μm filters.

Membranes that display the highest particle retention tend to be the most effective at minimizing backpressure. Polypropylene membranes exhibit poor particle retention, and therefore filtering UHPLC mobile phases through polypropylene is the least effective for reducing backpressure buildup. In contrast, filtering the mobile phase through PTFE membranes, which show excellent particle retention, enabled the UHPLC system to run without significant backpressure buildup.

Filtration through 0.2 μm hydrophilic PTFE Millex[®] filters prevents backpressure buildup on a UHPLC system.

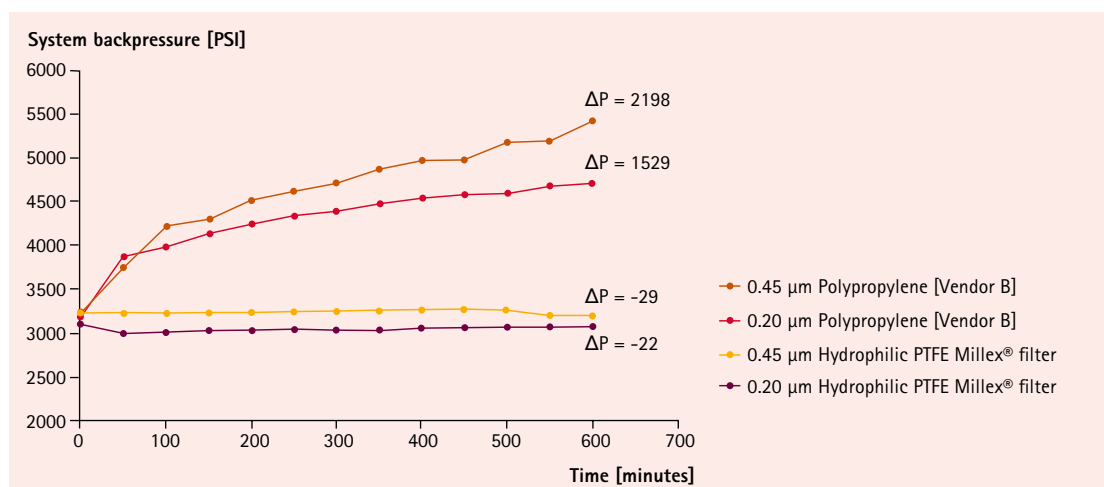

► For further information please have a look at our website: www.millipore.com/filtration

Water and acetonitrile were passed through polypropylene or PTFE syringe filters (as indicated in legend), then used 1:1 (v/v) to prepare the mobile phase for UHPLC. The system was run at 0.25 mL/min for 600 min with backpressure recorded every 50 min. DP represents total change in backpressure after 600 min.

Filtration tools for preparing UHPLC buffers and mobile phases

Ordering information – Disc filters

Product	Ordering No.	Pore size	Filter diameter
Durapore® PVDF Membrane Filter	GVWP04700	0.2 µm	47 mm
Durapore® PVDF Membrane Filter	GVWP09050	0.2 µm	90 mm
Millipore Express® PLUS PES Membrane Filter	GPWP04700	0.2 µm	47 mm
Millipore Express® PLUS PES Membrane Filter	GPWP09050	0.2 µm	90 mm
Omnipore® PTFE Membrane Filter	JGWP04700	0.2 µm	47 mm
Omnipore® PTFE Membrane Filter	JGWP09025	0.2 µm	90 mm
Nylon Membrane Filter	GNWP04700	0.2 µm	47 mm
Fluoropore™ Membrane Filter	FGLP04700	0.22 µm	47 mm
Stericup®-GP Filter, 500 mL	SCGPU05RE	0.22 µm	
Steritop®-GP Filter, 500 mL	SCGPS05RE	0.22 µm	



Ordering information – Filter holders and pumps

Product	Ordering No.	Filter diameter
All glass filter holder with 250 mL funnel	XX1504700	47 mm
Glass filter holder with stainless steel screen, with 1 L funnel	XX1009020	90 mm
Filter forceps, blunt-tipped, sterilizable	XX6200006P	
Chemical Duty Vacuum Pump, 115 V	WP6111560	
Chemical Duty Vacuum Pump, 220 V	WP6122050	
Millivac® Vacuum Pump, 115 V	SD1M001V00	
Millivac® Vacuum Pump, 230 V	XF5423050	
Millivac® Maxi Vacuum Pump, 230 V	SD1P014M04	



Merck Millipore filters for preparing UHPLC samples

Reduce signal-to-noise ratios and maintain clean baselines by filtering samples with Millex® syringe filter units. With their broad chemical compatibility, low holdup volumes, and consistent quality, Millex® filters are ideal for preparing samples for UHPLC analysis.



Low analyte binding Millex® filters

Millex® filters with PTFE membrane consistently provide greater than 90% drug recovery in the first mL of filtrate, indicating low drug binding to PTFE.

Samples filtered through PTFE and nylon membrane syringe filters

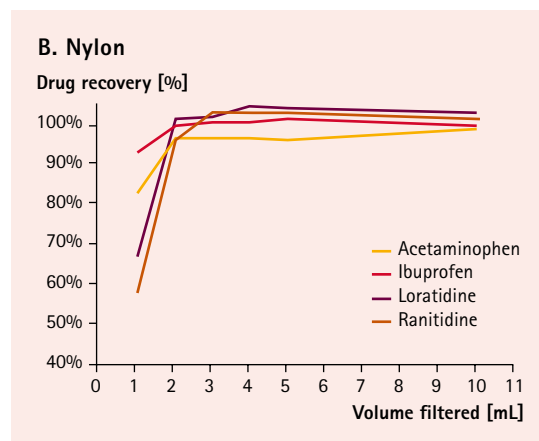
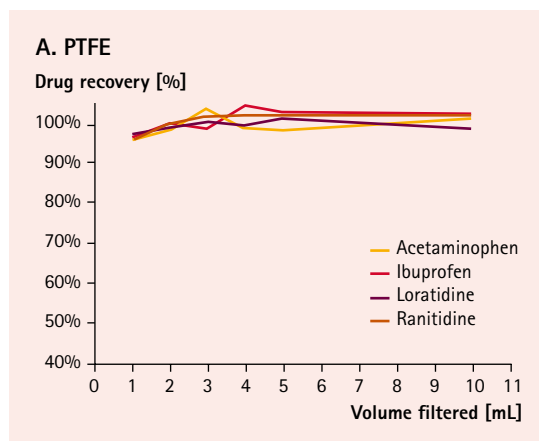

In drug dissolution tests, four different commercially available drug tablets (Acetaminophen, Ibuprofen, Loratidine, and Ranitidine) were dissolved in dissolution media. At the end of the dissolution period, samples were filtered through PTFE (A) and nylon (B) membrane syringe filters. Fractions were analyzed by UV spectroscopy.

Millex® filter units feature low extractables

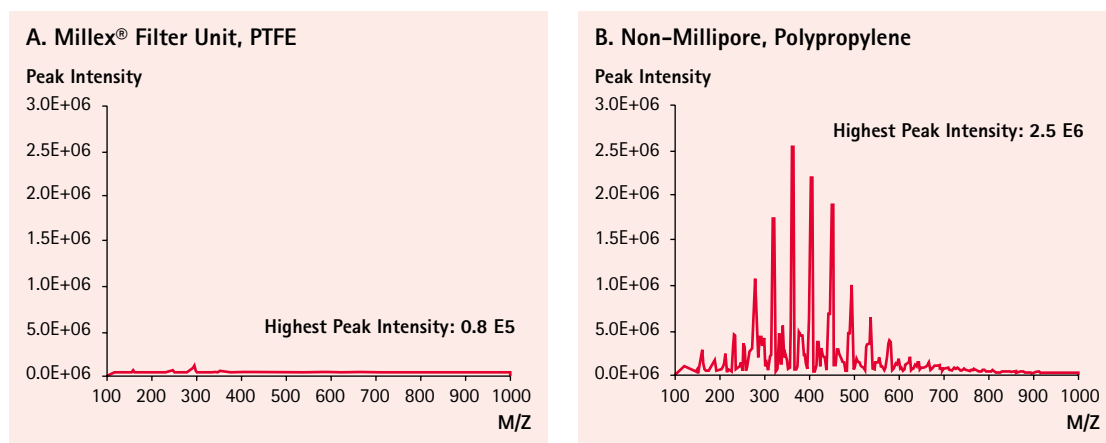

Mass spectrometry detects few extractable impurities from Millex® syringe filter (A) containing 0.45 µm pore hydrophilic PTFE membrane. In contrast, a syringe filter containing 0.45 µm pore polypropylene membrane (non-Merck Millipore, B) shows significant leaching of impurities.

Ordering information – Filtration tools for preparing UHPLC samples

UHPLC system manufacturers recommend filtering samples through 0.2 µm membranes for optimal removal of interfering particulates, better separation, and less column clogging.

Product	Ordering No.	Pore size	Filter diameter
PTFE Millex® Filter Unit	SLFGX13NL	0.2 µm	13 mm
PTFE Millex® Filter Unit	SLFG025NS	0.2 µm	25 mm
PTFE Millex®-LG Filter Unit	SLLGH25NB	0.2 µm	25 mm
PTFE Millex®-HPF LCR Filter Unit with prefilter	SLLGM25NS	0.2 µm	25 mm



Ordering information – Low extractable filtration

Low binding hydrophilic PTFE membrane filters both aqueous and organic solvents.

Product	Ordering No.	Pore size	Filter diameter
PTFE Millex®-LCR Filter Unit	SLCR013NL	0.45 µm	13 mm
PTFE Millex®-LCR Filter Unit	SLCR025NS	0.45 µm	25 mm

Millex® Syringe Filters

Automation-compatible filters



Applications

- Dissolution testing
- HPLC sample preparation

Membranes

- **Glass Fiber:** Clarifying aqueous or organic solutions with high particulate levels
- **Millex® LCR (hydrophilic PTFE)*:** Clarifying aqueous or organic solutions
- **Durapore® (PVDF)*:** Clarifying aqueous and mild organic solutions; ultra-low protein binding
- **Nylon*:** Clarifying aqueous or organic solutions
- **Multi-layer prefilter configuration:** Clarification of high particulate and viscous solutions

**Also available with glass fiber prefilter for clarifying solutions with high particulate levels.*

Automation-compatible filter benefits

- Engineered specifically for robotic systems, automation-compatible 25 mm Millex® Syringe Filters deliver trouble-free operation in automated filter changing stations
- Domed housing ensures reliable delivery of filters
- Pressure resistant housing resists bursting
- Luer-Lok® connection optimized for precise alignment and fit
- Available in either bulk or delivery tubes for use with automated filter changing system, including Caliper, Varian and Sotax workstations

Housings

- Low-extractable, high-density polyethylene

Merck Millipore advantage

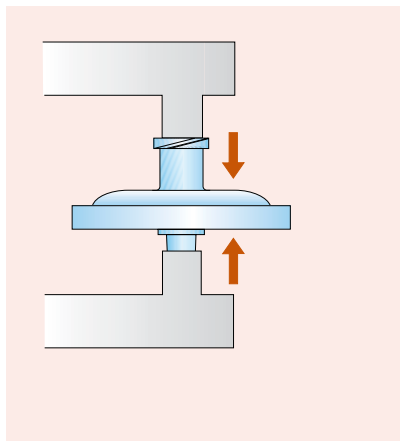

A rigid domed housing design helps prevent backpressure, which can cause a workstation shut-down.

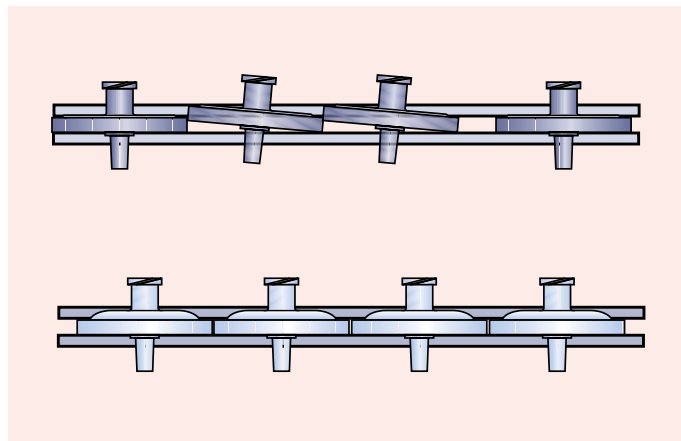

The domed housing of automation-compatible 25 mm Millex® Syringe Filters enables smooth, reliable delivery by eliminating shingling between filters in the transport rack.

► For further information please have a look at our website: www.millipore.com/filtration

Millex® Syringe Filters | Automation-compatible filter

Ordering information – Millex® Syringe Filters, 25 mm diameter | Automation-compatible filter

Product	Ordering No.	Content / Packaging	Pore size	Type	Process volume [max]
Glass Fiber Filter	SLPBDZ5NZ	200 (8x25)	1.0 µm	PB	100 mL
	SLPBDZ5NK	1000			
Millex® LCR (Hydrophilic PTFE) Membrane	SLLGDZ5NZ	200 (8x25)	0.20 µm	LG	100 mL
	SLLGDZ5NK	1000			
	SLCRDZ5NZ	200 (8x25)	0.45 µm	LCR	100 mL
	SLCRDZ5NK	1000			
Millex® LCR (Hydrophilic PTFE) Membrane with 1.0 µm Glass Fiber Prefilter	SLCRBZ5NZ	200 (8x25)	0.45 µm / 1.0 µm	LCR / PB	100 mL
	SLCRBZ5NK	1000			
Durapore® (PVDF) Membrane	SLHVDZ5NZ	200 (8x25)	0.45 µm	HV	100 mL
	SLHVDZ5NK	1000			
Durapore® (PVDF) Membrane with 1.0 µm Glass Fiber Prefilter	SLHVBZ5NZ	200 (8x25)	0.45 µm / 1.0 µm	HV / PB	100 mL
	SLHVBZ5NK	1000			
Nylon Membrane	SLHNDZ5NZ	200 (8x25)	0.45 µm	HN	100 mL
	SLHNDZ5NK	1000			
	SLGNDZ5NZ	200 (8x25)	0.20 µm	GN	100 mL
	SLGNDZ5NK	1000			
Nylon Membrane with 1.0 µm Glass Fiber Pre-filter	SLHNBZ5NZ	200 (8x25)	0.45 µm / 1.0 µm	HN / PB	100 mL
	SLHNBZ5NK	1000			

Standard (1000 packs) for individual use or 200 pack tubes for use on robotic systems.



Samplicity™ Filtration System

Break free from routine sample filtration

Samplicity™ is the ideal sample filtration system for most chromatographers

The first vacuum-driven system with the designed in flexibility to filter 1 to 8 samples directly into standard HPLC sample vials, the Samplicity™ Filtration System has the potential to break the sample prep bottleneck. Just attach a vacuum pump, load your samples, and flip the lever. Recover your particulate-free samples in seconds.

Built upon decades of our membrane filtration expertise, the system's Millex Samplicity™ Filters have a unique funnel shape for easy pipette loading and are provided in strips of four for faster loading. The filter strips are perforated for use with fewer samples.



*Choose the unit color to fit your lab –
bold blue or glossy green!*

Over 60% of chromatographers process 10–100 samples a day

Most chromatographers (65%, according to a recent Merck Millipore survey) process 10–100 samples a day into vials. For them, single-sample syringe filters and robotics and plate-based filtration systems are equally impractical. The Samplicity™ Filtration System eliminates the tedium of syringe filtration and the space requirements and expense of robotics.

The Samplicity™ Filtration System is ideal for medium throughput users in diverse fields, including:

- Drug dissolution testing – mandatory evaluation of the dissolution rate of solid dosage forms in the digestive tract
- Food safety – testing foods and beverages for unknown and known toxins, including glycol, melamine, and cyanobacteria
- Cosmetics – separation and detection of cosmetic ingredients and formulations
- Biofuels – analysis and extraction of lipids from algae and other biomass
- Pharmacokinetic/pharmacodynamic (PK/PD) testing – quantification of interactions of drugs with the body with respect to time

Low throughput

[1–10 samples/day]



Medium throughput

[10–100 samples/day]



High throughput

[> 96 samples/day]



The Samplicity™ Filtration System outperforms manual filtration

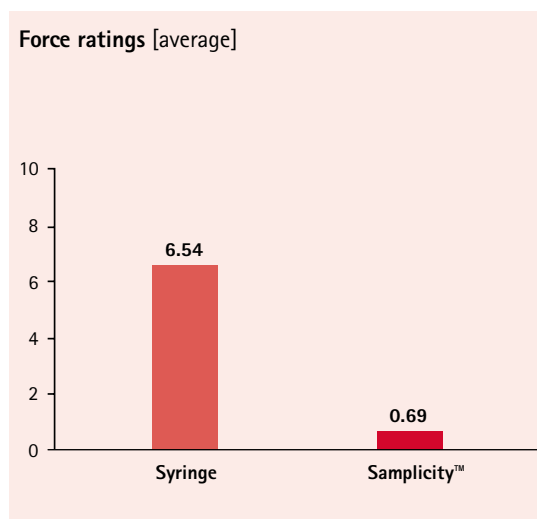
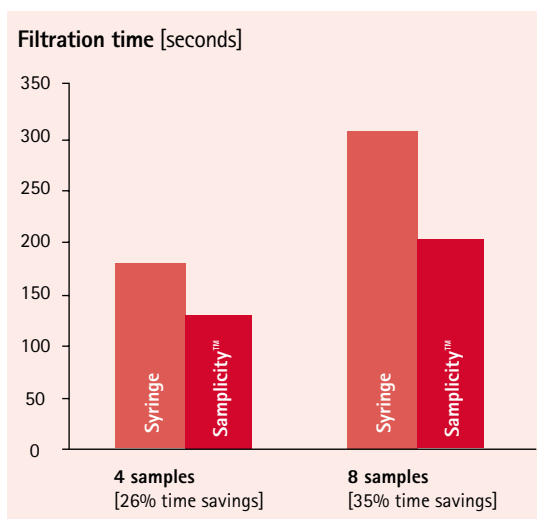

Faster processing time: Up to eight samples in seconds.

To compare the speed of the Samplicity™ system with syringe filtration, either four or eight 1.0 mL samples of 1% Pepto-Bismol (viscosity 7-10 cP) were filtered by 13 users. On average, the Samplicity™ system accelerated four-sample filtration by 26%, and it accelerated eight-sample filtration by 35%.*

No sample foaming or bubbles, for better sample recovery and accurate autosampling.

Average user ratings of manual force required and comfort levels for operating syringe filters versus the Samplicity™ Filtration System show the Samplicity™ system requires virtually no manual force for filtration.

Ergonomic benefits: Less force, more comfort.

Average user ratings of manual force required and comfort levels for operating syringe filters versus the Samplicity™ Filtration System show the Samplicity™ system requires virtually no manual force for filtration.*



*The information presented is based on preliminary development results. Device performance in specific applications may be different.

Millex Smplicity™ Filters

Provide maximum versatility with highest quality.

Built on over 40 years of membrane expertise

Millex Smplicity™ filters were designed with the best, most versatile membrane for filtering chromatography samples – our hydrophilic polytetrafluoroethylene (PTFE) filters retain > 95% of particulate impurities.

Higher yields for small sample volumes:

low holdup volume enables you to do more analyses with each precious sample.

Syringe filtration

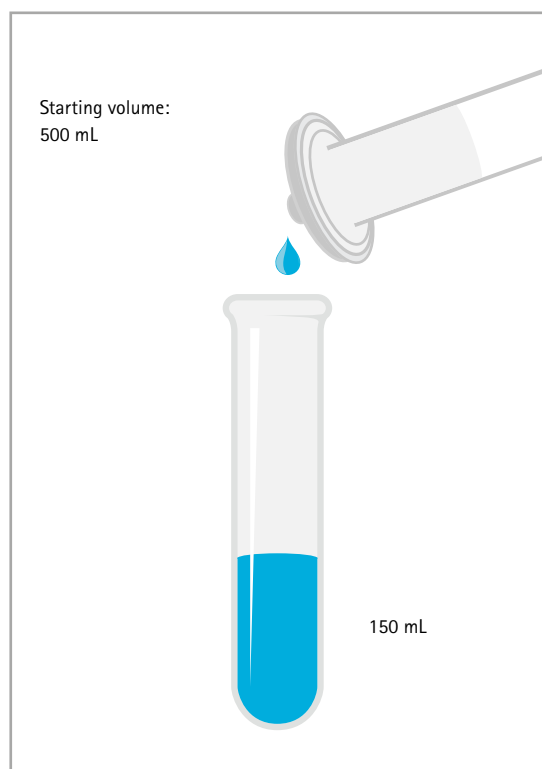

Smplicity™ filtration

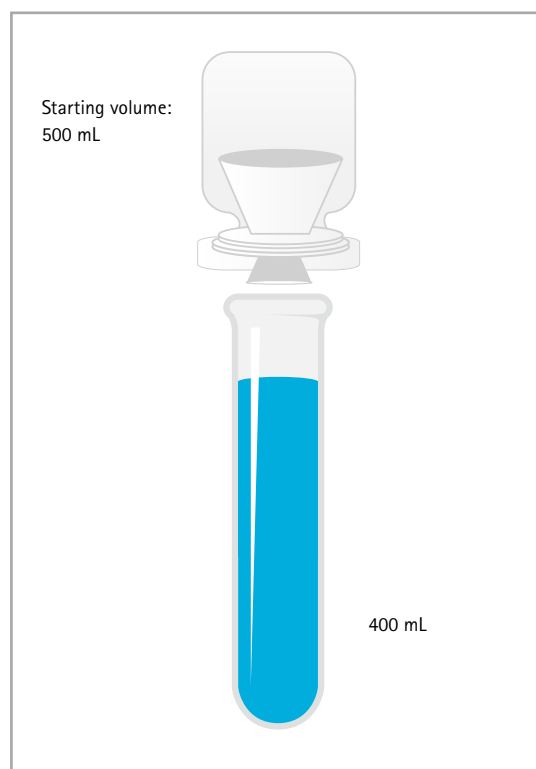

Pre-washing Millex Smplicity™ Filters is easy.

If your application requires pre-washing filters prior to final filtration and analysis, a waste tray can be inserted into the Smplicity™ system to facilitate this step. When pre-washing filters using the Smplicity™ system, the waste tray is placed on the base in place of the vial tray and the solvent or sample is filtered through the Millex Smplicity™ filters using vacuum, similar to normal operation. Once the filters are pre-washed, use the same filters for sample filtration and collection into vials.

Low extractables from hydrophilic PTFE: broad chemical compatibility of hydrophilic PTFE mean fewer leached impurities can contaminate the sample for downstream analysis.

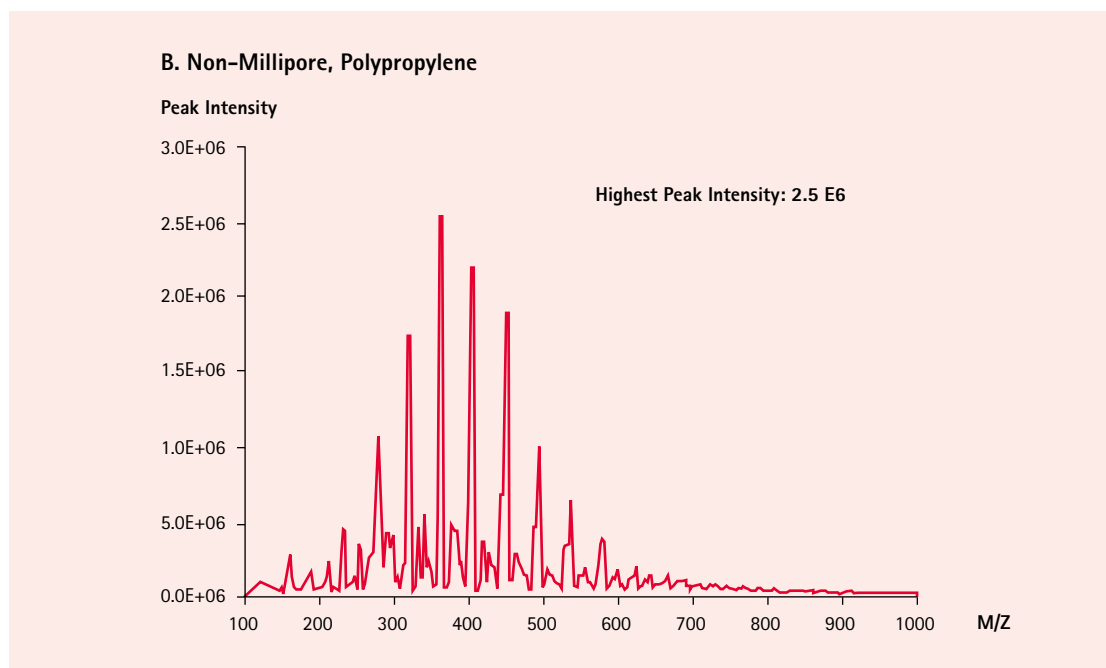
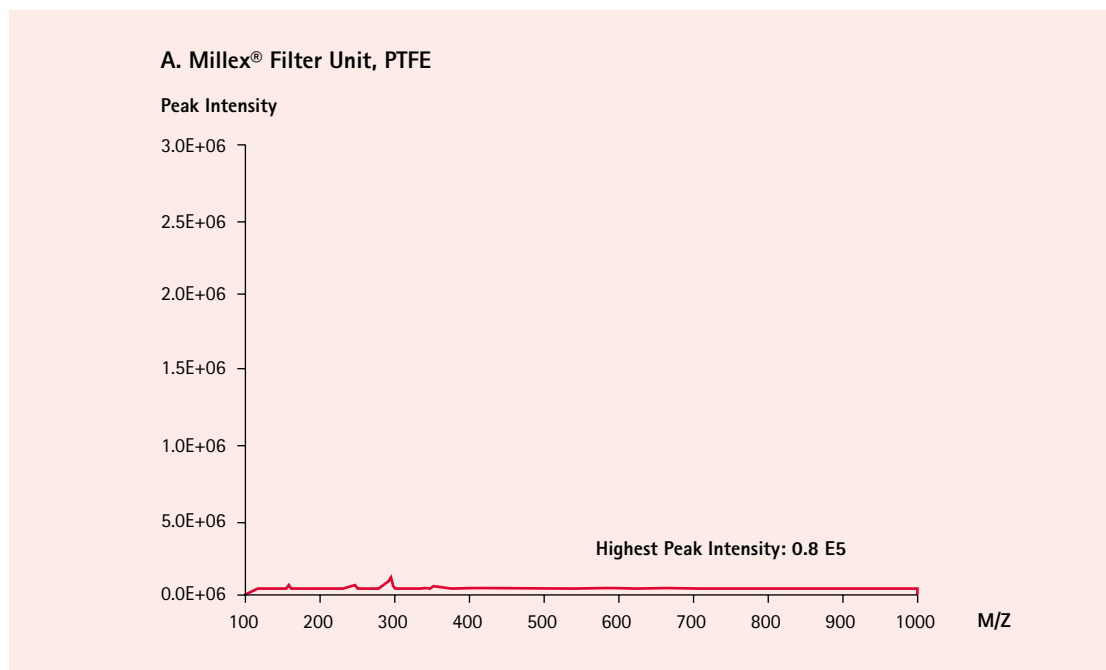

Mass spectrometry detects few extractable impurities from Millex® syringe filter (A) containing 0.45 µm pore hydrophilic PTFE membrane. In contrast, a syringe filter containing 0.45 µm pore polypropylene membrane (non-Merck Millipore, B) shows significant extractables.

Low analyte binding: waste less sample during filtration so you can accurately quantitate low levels of analytes present in the sample.

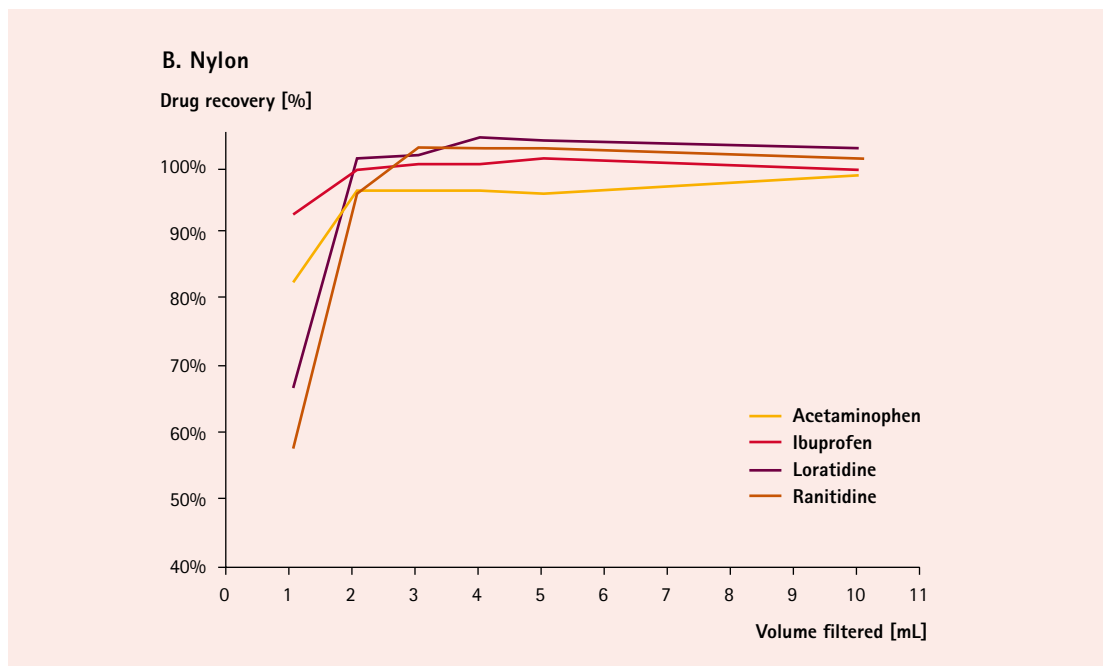
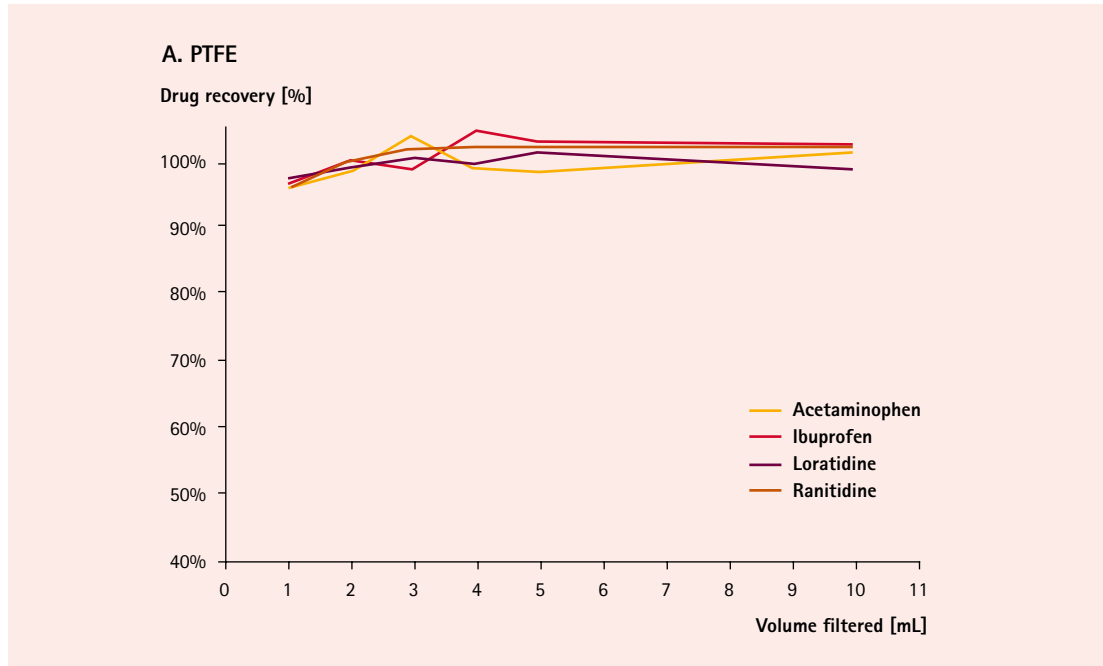

Hydrophilic PTFE membrane consistently provides greater than 90% drug recovery in the first mL of filtrate, indicating low drug binding to PTFE compared to nylon. Four drug samples were filtered through Millex® Syringe Filters containing PTFE or nylon.

Samplicity™ Filtration System

Now you can truly do more with less.

Combine the Samplicity™ Filtration System with state-of-the-art separation technologies.

The Samplicity™ system provides higher yields with low hold-up volume, fast processing, and ease of use. And in addition to ergonomic benefits, the system creates less waste than syringe filtration and eliminates the need to segregate syringe waste. Together with Merck Millipore's mobile phases, solvent filtration systems, columns, and water purification systems, the Samplicity™ Filtration System is the key to staying on the cutting edge of chromatographic separation.

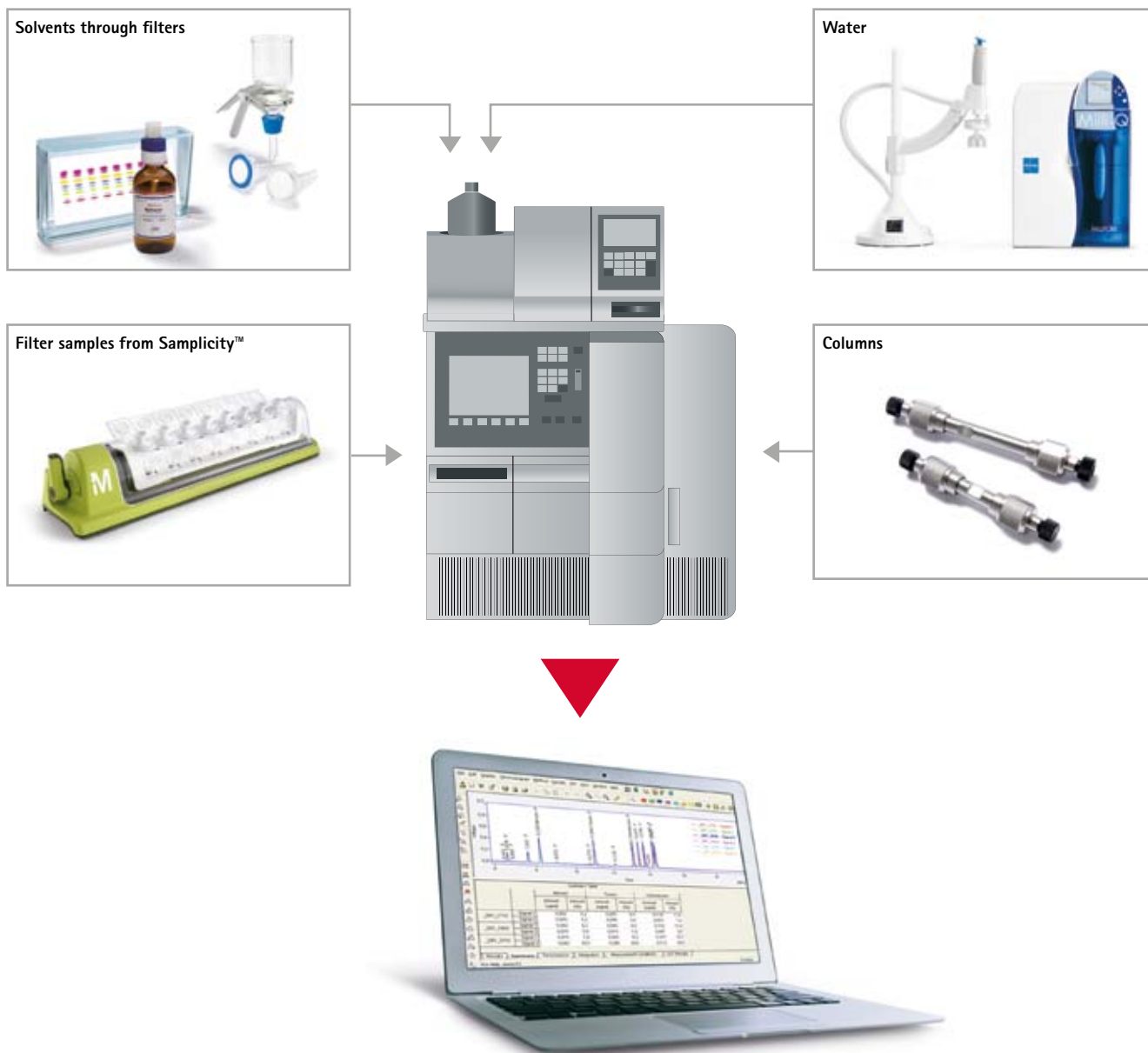

Ordering information – Samplicity™ systems and accessories

Product	Ordering No.	Content / Packaging	Color
Samplicity™ Filtration System	SAMPSYSGR	1	glossy green
Samplicity™ Filtration System	SAMPSYSBL	1	bold blue
Samplicity™ Filtration System Vial Trays	SAMVIALTR	2	
Samplicity™ Filtration System Waste Trays	SAMWASTTR	5	
Samplicity™ Filtration System Tube Set Assembly	SAMTUBING	1	
Samplicity™ Filtration System Replacement Lid	SAMSYSLID	1	



Choose the unit color to fit your lab – bold blue or glossy green!

Ordering information – Millex Samplicity™ Filters

Product	Ordering No.	Content / Packaging	Pore size	Type
Millex Samplicity™ Filters	SAMPLG001	96	0.20 µm	Hydrophilic PTFE
Millex Samplicity™ Filters	SAMPLCR01	96	0.45 µm	Hydrophilic PTFE
Millex Samplicity™ Filters	SAMPLG004	394	0.20 µm	Hydrophilic PTFE
Millex Samplicity™ Filters	SAMPLCR04	394	0.45 µm	Hydrophilic PTFE



Ordering information – Required accessories for Samplicity™ Filtration System

Product	Ordering No.	Volt [V]	Hertz [Hz]
Chemical Duty Pump	WP6111560	115 V	60 Hz
Chemical Duty Pump	WP6122050	220 V	50 Hz
Chemical Duty Pump	WP6110060	100 V	50–60 Hz



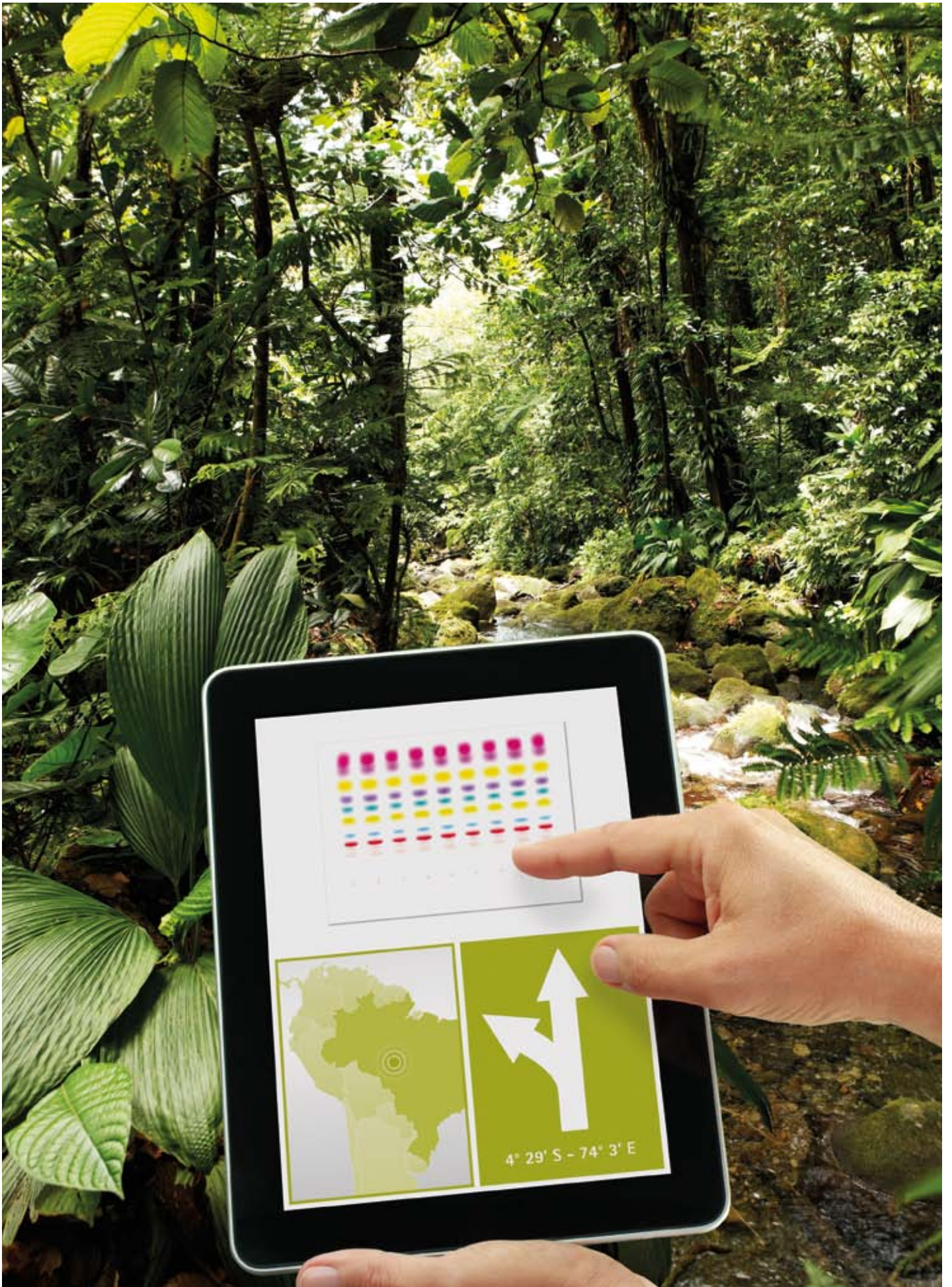

Thin Layer Chromatography

There are infinite unexplored regions on our planet with an abundance of potential. The chance to heal, cure and create lies everywhere. But in order to examine the opportunity, it is necessary to reach the destination loaded with various lab instruments. Why not take an easier route? Leave the burden behind with Thin Layer Chromatography (TLC) solutions from Merck Millipore. Quick and convenient, these products are simple to use, which makes them ideal for screening on location. We offer TLC plates that can be used for a broad spectrum of applications – absolutely anywhere. So whether you are in quest of the next herbal breakthrough, or in the factory testing the quality of your food products, you can rely on our TLC solutions to reach your goal faster and easier.

03

Contents

Thin Layer Chromatography	page 93
Classical silica TLC plates (TLC) For versatile and reliable routine analysis of a broad range of substances	page 94
Aluminium oxide TLC plates For basic and neutral compounds using different pH conditions	page 97
Kieselguhr and mixed layer plates For specific applications	page 98
High performance silica plates (HPTLC) For fast analysis of complex samples for manual or instrumental use	page 99
LiChrospher® HPTLC	page 102
RP-modified silica plates (TLC and HPTLC) Free choice of solvent system for special separations and as pilot method for HPLC	page 104
CN-, Diol- and NH ₂ -modified plates (TLC and HPTLC) For special separation problems	page 107
Cellulose TLC and HPTLC For analysis of polar substances	page 109
PEI (Polyethylenimine) Cellulose For specific separations by ion-exchange chromatography	page 111
Concentrating zone plates (TLC, HPTLC, PLC) Quick and easy sample application even of large volumes of diluted samples	page 112
ProteoChrom® HPTLC plates For peptide analysis	page 115
Multiformat plates (TLC and HPTLC) Multiple sizes in one single glass plate	page 118
GLP plates (TLC and HPTLC) With individual laser coding for GLP applications	page 119
Preparative layer plates (PLC) For enrichment of target analytes in mg quantities and sample clean-up	page 120
Loose sorbents for preparation of TLC plates Standardized sorbents for reliable results	page 121
Accessories	page 123
Technical appendix	page 124

Thin Layer Chromatography

Fast separation of a broad range of substances

Thin Layer Chromatography (TLC) is a simple, fast and highly versatile separation tool for both qualitative and quantitative analyses. The field of application covers virtually all classes of substances including pesticides, steroids, alkaloids, lipids, nucleotides, glycosides, carbohydrates, fatty acids and many others.

Advantages of TLC:

- Economical separation method without the need for sophisticated instruments
- No cumbersome sample preparation step needed because plates are disposable
- Sample components are stored on the plate, allowing the analysis to be repeated several times
- Multiple samples (up to 72) can be run simultaneously under identical conditions
- Easy 2-dimensional separation by using two distinct mobile phases in different directions

Apart from the manual method of classical TLC, the technique can also be automated as in instrumental high-performance Thin Layer Chromatography (HPTLC). Furthermore, it can be easily extended to preparative scale for PLC.

Unique quality from the pioneer in Thin Layer Chromatography

As a pioneer in TLC, Merck Millipore introduced the first pre-coated plates on the market. And we continue to develop innovative products to meet the requirements of today's demanding applications.

Merck Millipore offers reliable TLC plates in a wide range of chemistries, sizes and backings to suit a variety of applications. They combine robustness with the highest surface homogeneity for unsurpassed separation. Our HPTLC plates provide even greater sensitivity and standardization. Merck Millipore quality is renowned and proven by countless TLC applications in chromatographic studies.

Classical silica TLC plates (TLC)

For versatile and reliable routine analysis of a broad range of substances

Silica gel is the most universal adsorbent used in TLC because it covers almost every type of separation by suitable choice of the mobile phase.

Merck Millipore classical silica TLC plates are based on proven Merck Millipore silica gel 60 with a pore diameter of 60 Å, a pore volume of 0.8 mL/g and a specific surface of 520 m²/g (BET). The unique polymeric binder results in a very adherent and hard surface that will not crack or blister and even allows writing with a pencil on the surface without risk of damaging the layer. The smooth and dense plate surface guarantees sharp bands for maximum separation efficiency with lowest background noise, e.g. when performing scanning densitometry.

Classical silica TLC plates have either a layer thickness of 250 µm (glass plates) or 200 µm (aluminium, plastic plates) and a mean particle size of 10 - 12 µm. They are available glass, aluminium or plastic backed in a broad range of different sizes to suit many application needs. The flexible backed aluminium or plastic plates can easily be cut with scissors to match individual separation requirements.



The flexible backed aluminium or plastic plates can easily cut with scissors to individual sizes

Specifications of classical TLC plates

Mean particle size	10 - 12 µm
Particle size distribution	5 - 20 µm
Layer thickness	250 µm, glass 200 µm, aluminium, plastic
Typical plate height	30 µm
Typical migration distance	10 - 15 cm
Typical separation time	20 - 200 min
Number of samples per plate	10

► **RP-modified silica plates (TLC and HPTLC)** Free choice of solvent system for special separations and as pilot method for HPLC
page 104

► **CN-, Diol- and NH₂-modified plates (TLC and HPTLC)** For special separation problems
page 107

► **Concentrating zone plates (TLC, HPTLC and PLC)** Quick and easy sample application even of large volumes of diluted samples
page 112

For UV detection of colorless substances, plates with two kinds of fluorescent indicator are available: green fluorescing F₂₅₄ (manganese activated zinc silicate) or blue fluorescing F_{254s} (magnesium wolframate). In addition, F_{254s} is highly stable in acidic solvent systems. Both indicators fluoresce in UV light at an excitation wavelength of 254 nm. Samples which absorb short-wave UV at 254 nm are detected due to fluorescence quenching.

Specially developed high-fluorescence LuxPlates® contain a higher content of fluorescent indicator for further improved identification of separate zones. In addition, the higher amount of binder results in an even more robust and abrasion-resistant surface.

Ordering information – TLC silica gel 60, glass backed

Product	Ordering No.	Format [cm]	Contents of one package
Silica gel 60 F ₂₅₄	1.05715.0001	20 x 20	25 plates
	1.05714.0001	5 x 20	100 plates
	1.05729.0001	10 x 20	50 plates
Silica gel 60	1.05721.0001	20 x 20	25 plates
	1.05626.0001	10 x 20	50 plates
	1.05724.0001	5 x 20	100 plates
	1.15326.0001	2.5 x 7.5	100 plates
Silica gel 60 F ₂₅₄	1.05808.0001	5 x 20	25 plates
	1.05719.0001	5 x 10	200 plates
	1.05789.0001	5 x 10	25 plates
	1.15327.0001	2.5 x 7.5	100 plates
	1.15341.0001	2.5 x 7.5	500 plates
Silica gel 60 WF _{254s}	1.16485.0001	20 x 20	25 plates
LuxPlate® silica gel 60 F ₂₅₄	1.05805.0001	20 x 20	25 plates
	1.05804.0001	10 x 20	50 plates
	1.05802.0001	5 x 10	25 plates
	1.05801.0001	2.5 x 7.5	100 plates

Layer thickness: 250 µm | W: Water resistant | F₂₅₄: Green fluorescent indicator | F_{254s}: Blue fluorescent indicator

Ordering information – TLC silica gel 60, aluminium backed

Product	Ordering No.	Format [cm]	Contents of one package
Silica gel 60	1.05553.0001	20 x 20	25 sheets
	1.16835.0001	5 x 10	50 sheets
Silica gel 60 W	1.16487.0001	20 x 20	25 sheets
Silica gel 60 F ₂₅₄	1.05554.0001	20 x 20	25 sheets
	1.05570.0001	10 x 20	25 sheets
	1.16834.0001	5 x 10	50 sheets
	1.05549.0001	5 x 7.5	20 sheets
	1.05562.0001	500 x 20	1 roll
Silica gel 60 WF _{254s}	1.16484.0001	20 x 20	25 sheets

Layer thickness: 200 µm | W: Water resistant | F₂₅₄: Green fluorescent indicator | F_{254s}: Blue fluorescent indicator

Classical silica TLC plates (TLC)

Ordering information – TLC silica gel 60, plastic backed

Product	Ordering No.	Format [cm]	Contents of one package
Silica gel 60	1.05748.0001	20 x 20	25 sheets
Silica gel 60 F ₂₅₄	1.05735.0001	20 x 20	25 sheets
	1.05750.0001	4 x 8	50 sheets
	1.05749.0001	500 x 20	1 roll

Layer thickness: 200 µm | F₂₅₄: Green fluorescent indicator

Applications of classical silica TLC

Unmodified silica gel covers more than 80% of Thin Layer Chromatography applications for both adsorption- and partition Thin Layer Chromatography. It allows separation of a large range of different substances such as aflatoxins, alkaloids, anabolics, benzodiazepines, carbohydrates, fatty acids, glycosides, lipids, mycotoxins, nucleotides, peptides, pesticides, steroids, sulfonamides, surfactants, tetracyclines and many others making it suitable for:

- In-process control of drugs
- Purity checking of synthesis steps
- Identity testing of pharmaceutical compounds



Merck Millipore TLC plates deliver highly reproducible sharp bands over the whole plate as demonstrated by the parallel separation of a lipophilic dye mixture on a silica gel 60 classical TLC plate

Analysis of a sulfonamide mixture on TLC silica gel 60

Sample	1. Sulfadiazine 2. Sulfamerazine 3. Sulfisoxalozole 4. Sulfapyridine 5. Sulfanilamide (all 0.1%)
Sample volume	0.75 µL
Mobile phase	Ethyl acetate / methanol / ammonia solution 25% (60/20/2) (v/v/v)
Detection	UV 254 nm (TLC/HPTLC Scanner 2/CAMAG)

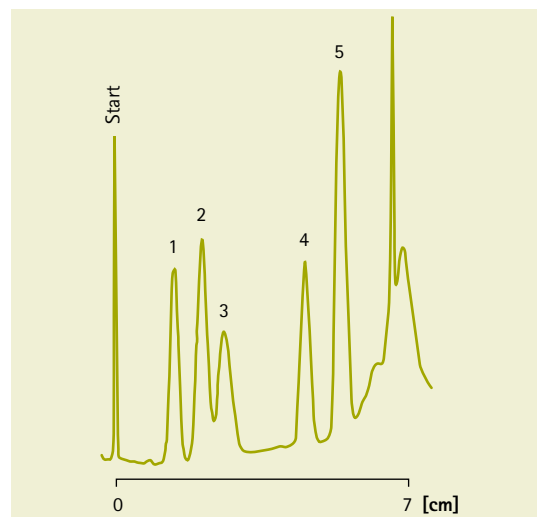

Analysis of a sulfonamide mixture on a TLC silica gel 60 reveals clear separation of five different antibacterial drugs.

Aluminium oxide TLC plates

For basic and neutral compounds using different pH conditions

Merck Millipore TLC aluminium oxide plates utilize neutral or basic aluminium oxide of 60 Å or 150 Å pore size with or without fluorescence indicator to suit different application needs. Aluminium oxide plates provide distinct separation features with regard to the pH range used: Under aqueous conditions basic compounds can be best separated on basic aluminium oxide plates, while neutral compounds are best separated on neutral plates.

Ordering information – TLC aluminium oxide 60

Product	Ordering No.	Format [cm]	Layer thickness	Backing	Contents of one package
Aluminium oxide 60 F ₂₅₄ basic	1.05713.0001	20 x 20	250 µm	glass	25 plates
Aluminium oxide 60 F ₂₅₄ basic	1.05731.0001	5 x 20	250 µm	glass	100 plates
Aluminium oxide 60 F ₂₅₄ neutral	1.05550.0001	20 x 20	200 µm	aluminium	25 sheets
Aluminium oxide 60 F ₂₅₄ neutral	1.05581.0001	20 x 20	200 µm	plastic	25 sheets

F₂₅₄: Green fluorescent indicator

Ordering information – TLC aluminium oxide 150

Product	Ordering No.	Format [cm]	Layer thickness	Backing	Contents of one package
Aluminium oxide 150 F ₂₅₄ neutral	1.05551.0001	20 x 20	200 µm	aluminium	25 sheets

F₂₅₄: Green fluorescent indicator



Kieselguhr and mixed layer plates

For specific applications

Kieselguhr is a natural diatomaceous earth that can be used for the separation of polar or moderately polar substances. Merck Millipore's mixed layer plates utilize a combination of classical silica gel 60 and kieselguhr to provide good separation properties for certain special applications such as separation of inorganic ions, herbicides and some steroids.

Ordering information – TLC plates, kieselguhr, silica gel/kieselguhr

Product	Ordering No.	Format [cm]	Layer thickness	Contents of one package
TLC glass plates Kieselguhr F ₂₅₄	1.05738.0001	20 x 20	0.2 mm	25 plates
TLC aluminium plates Kieselguhr F ₂₅₄	1.05568.0001	20 x 20	0.2 mm	25 sheets
TLC aluminium plates silica gel 60/Kieselguhr F ₂₅₄	1.05567.0001	20 x 20	0.2 mm	25 sheets

F₂₅₄: Green fluorescent indicator

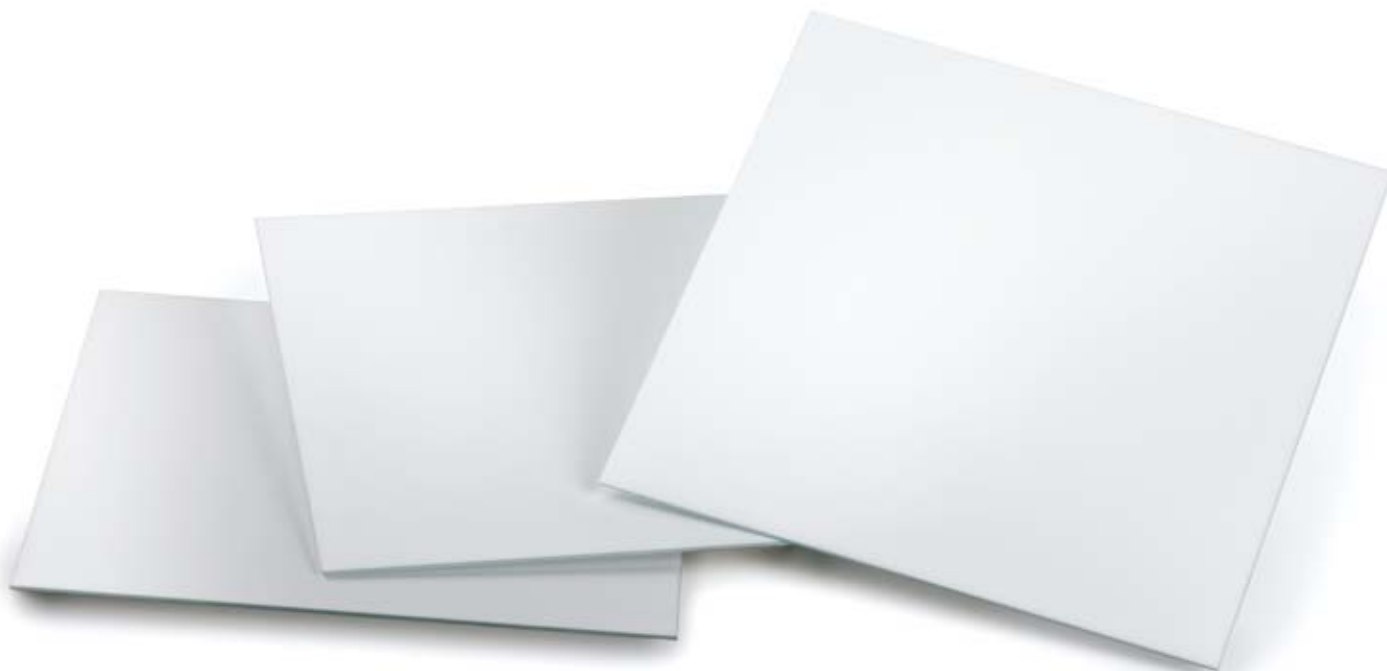

High performance silica plates (HPTLC)

For fast analysis of complex samples for manual or instrumental use

Merck Millipore HPTLC silica plates offer higher speed and higher sensitivity than classical TLC and are therefore optimally suited for sophisticated separations.

Using instrumental equipment HPTLC plates makes for modern, quantitative Thin Layer Chromatography. HPTLC plates utilize an optimized silica 60 sorbent with a particle size of only 5-6 μm . The smaller particles give a smoother surface and a higher separation power than conventional TLC plates. Band diffusion is reduced, giving rise to very compact sample bands or zones. These features and the thinner layer (< 200 μm) ultimately result in highly increased sensitivity and faster analysis. HPTLC silica plates are available either glass or aluminium backed in a variety of different formats to suit various separation needs. Just as in the classical range, two kinds of fluorescent indicators are used: the green fluorescing F_{254} and the blue fluorescing acid-stable F_{254s} . Both indicators fluoresce in UV light at an excitation wavelength of 254 nm.

Specifications of HPTLC versus classical TLC plates

	HPTLC	TLC
Mean particle size	5-6 μm	10 - 12 μm
Particle size distribution	4 - 8 μm	5 - 20 μm
Layer thickness	200 μm (100 μm)	250 μm (200 μm)
Typical plate height	12 μm	30 μm
Typical migration distance	3 - 6 cm	10 - 15 cm
Typical separation time	3 - 20 min	20 - 200 min
Number of samples per plate	< 36 (72)	< 10
Sample volume	0.1 - 0.5 μl	1 - 5 μl
Detection limits absorption	100 - 500 μg	1 - 5 ng
Detection limits fluorescence	5 - 10 μg	50 - 100 μg

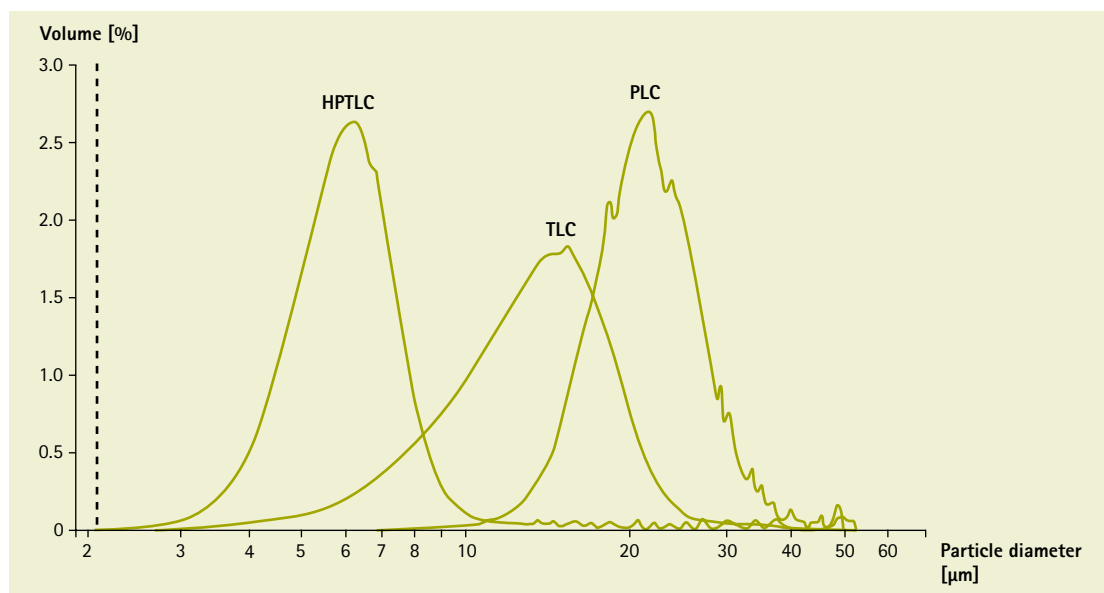

Comparison of the particle size distribution of TLC, HPTLC and PLC

- ▶ **RP-modified silica plates (TLC and HPTLC)** Separations and as pilot method for HPLC **page 104**
- ▶ **CN-, Diol- and NH₂-modified plates (TLC and HPTLC)** For special separation problems **page 107**
- ▶ **Concentrating zone plates (TLC, HPTLC, PLC)** Quick and easy sample application even of large volumes of diluted samples **page 112**
- ▶ **ProteoChrom® HPTLC plates for peptide analysis** **page 115**

High-performance silica plates (HPTLC)

HPTLC plates AMD with an extra thin layer of only 100 µm have been specifically developed for even more demanding applications such as automated multiple development (AMD). It combines the repeated development of the plate in the same direction and reproducible gradient elution. AMD development provides extremely narrow bands, allowing the complete resolution of up to 40 components over a distance of 60 mm.

HPTLC Premium Purity plates are designed for high performance, completely contamination-free separations especially in demanding pharmacopeial applications.

- Highly pure, exhibiting minimal background even with medium-polar solvent systems
- Identical separation performance to the related HPTLC plate product
- Especially suited for pharmacopeial applications

HPTLC Premium Purity plates are based on the HPTLC Silica gel 60 F₂₅₄ plate but in addition are carefully wrapped in dedicated plastic coated aluminium foil. The special packing prevents any deposition of plasticizers such as phthalates from the wrapping material that could appear as unknown extra zones when using medium-polar solvent systems such as toluene / ethyl acetate (95/5) and which can be stained by derivatization reagents.

Ordering information – HPTLC silica gel 60, glass backed

Product	Ordering No.	Format [cm]	Contents of one package
HPTLC silica gel 60	1.05641.0001	20 x 10	50 plates
	1.05631.0001	10 x 10	25 plates
	1.05633.0001	10 x 10	100 plates
HPTLC silica gel 60 F ₂₅₄	1.05642.0001	20 x 10	50 plates
	1.05628.0001	10 x 10	25 plates
	1.05629.0001	10 x 10	100 plates
	1.05616.0001	5 x 10	25 plates
HPTLC silica gel 60 F _{254s}	1.15696.0001	20 x 10	25 plates
HPTLC silica gel 60 WR F _{254s}	1.15552.0001	20 x 10	25 plates
HPTLC silica gel 60 AMD extra thin layer *	1.11764.0001	20 x 10	25 plates
HPTLC silica gel 60 AMD WR F _{254s} extra thin layer *	1.12363.0001	20 x 10	25 plates
HPTLC silica gel 60 / Premium Purity Plate	1.05648.0001	20 x 10	50 plates
HPTLC silica gel 60 Prescored	1.05644.0001	5 x 5	100 plates

Layer thickness: 200 µm / * 100 µm | W: Water resistant | F₂₅₄: Green fluorescent indicator | F_{254s}: Blue fluorescent indicator

Ordering information – HPTLC silica gel 60, aluminium backed

Product	Ordering No.	Format [cm]	Contents of one package
HPTLC silica gel 60	1.05547.0001	20 x 20	25 sheets
HPTLC silica gel 60 F ₂₅₄	1.05548.0001	20 x 20	25 sheets
	1.05556.0001	5 x 7.5	20 sheets

Layer thickness: 200 µm | F₂₅₄: Green fluorescent indicator

Application of high performance silica plates (HPTLC)

HPTLC plates are ideal for highly demanding, quantitative analysis such as:

- Identity testing in analysis of herbal medicines & medicinal plants
- Highly sophisticated, quantitative separations such as quality control of drugs using instrumental equipment
- Quality or purity testing of complex samples in pharmaceutical QC
- Trace analysis in food

A. Classical TLC silica gel 60 plate

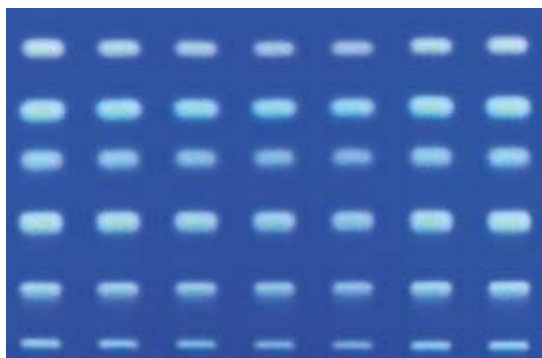

B. HPTLC silica gel 60 plate



Comparison of the separation of dansyl amino acids under identical conditions. The comparison clearly demonstrates that the HPTLC plate delivers sharper zones with shorter migration distances and faster analysis times. In addition the HPTLC plate allows the separation of twice the number of samples simultaneously.

Comparison of classical TLC versus HPTLC plates

	(A) TLC	(B) HPTLC
Sample	1. N-alpha-dansyl-L-asparagine 2. alpha-dansyl-L-arginine 3. Dansyl-L-cysteic acid 4. N-Dansyl-L-serine 5. Dansyl-glycine 6. N-N-Didansyl-L-tyrosine	
Mobile phase	Ethyl acetate/methanol/propionic acid (22/10/3)	
Detection	UV 366	
Sample volume	4 µm	0.3 µm
Migration distance	10 cm	5 cm
Analysis time	42 min	13 min 45 sec

In order to fully exploit the potential of HPTLC plates to deliver reliable and reproducible quantitation, appropriate instrumentation for sample application and data evaluation is essential. Please refer to the comprehensive CAMAG product range under www.camag.com.

LiChrospher® HPTLC

For fast analysis of complex samples for manual or instrumental use

Unique HPTLC LiChrospher® plates are the only Thin Layer Chromatography products based on spherical silica particles. They offer the ultimate in Thin Layer Chromatography performance and speed enabling high throughput analysis of complex samples.

- Further 20% reduced running times
- Highly compact zones
- Lower detection limits

HPTLC LiChrospher® plates are based on LiChrospher®, Merck Millipore's proven spherical shaped silica 60 with a small particle size of 7 µm and narrow particle size distribution as normally used in HPLC. LiChrospher® has a broad selectivity, very similar to the respective HPTLC plate; however plate height, separation numbers and velocity constants are even further improved.

A. LiChrospher® HPTLC plate

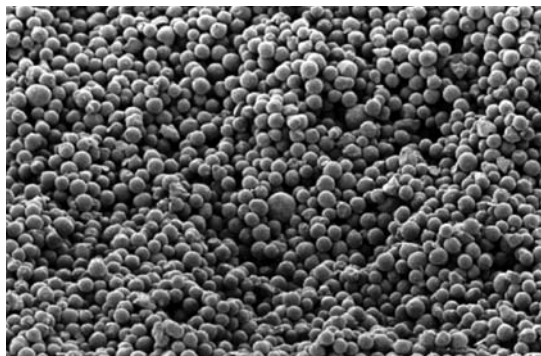

B. HPTLC silica plate



Scanning electron microscope pictures of the cross section of (A) a LiChrospher® HPTLC plate and (B) a HPTLC silica plate

Analysis times on a HPTLC LiChrospher® compared with a normal HPTLC plate

Eluent	Migration distance	LiChrospher® silica gel 60 F _{254s}	HPTLC silica gel 60 F ₂₅₄
Toluene	4 cm	4 min	5 min, 45 sec
Ethyl acetate / toluene (95-5)	5 cm	6 min	7 min, 50 sec
Methyl ethyl ketone / 1-propanol / water / acetic acid (40+40+20+5)	5 cm	20 min	26 min, 30 sec
n-Hexane / toluene / acetone (70+20+10)	7 cm	13 min	19 min

F₂₅₄: Green fluorescent indicator | F_{254s}: Blue fluorescent indicator

Ordering information – HPTLC LiChrospher® silica gel 60

Product	Ordering No.	Format [cm]	Backing	Contents of one package
HPTLC LiChrospher® silica gel 60 F _{254s}	1.15445.0001	20 x 10	glass	25 plates
HPTLC LiChrospher® silica gel 60 F _{254s}	1.05586.0001	20 x 20	aluminium	25 sheets
HPTLC LiChrospher® silica gel 60 AMD WR F _{254s} extra thin *	1.05647.0001	20 x 10	glass	25 plates

Layer thickness: 200 µm / * 100 µm | F_{254s}: Blue fluorescent indicator

Ordering information – HPTLC LiChrospher® RP-modified silica gel 60

Product	Ordering No.	Format [cm]	Backing	Contents of one package
HPTLC LiChrospher® silica gel 60 RP-18 WF _{254s}	1.05646.0001	20 x 10	glass	25 plates

Layer thickness: 200 µm | F₂₅₄: Green fluorescent indicator

Applications of LiChrospher® HPTLC

LiChrospher® HPTLC plates are suitable for a broad range of applications but especially for the analysis of highly complex low concentration samples, e.g. **analysis of pesticides mixtures** or **assaying of pharmaceutical compounds**.

A. HPTLC LiChrospher® Si 60 plate

B. Conventional HPTLC Si 60 plate

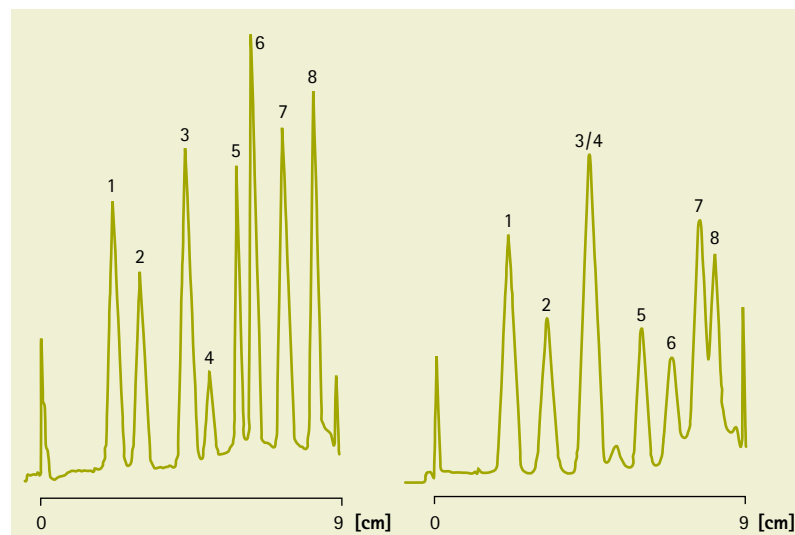

Pesticide separation on (A) HPTLC LiChrospher® and on a conventional (B) HPTLC plate demonstrating that using LiChrospher® plates allows the separation of more substances.

Pesticide separation

Sample	1. Hexazinone 2. Metoxuron 3. Monuron 4. Aldicarb 5. Azinphos-methyl 6. Prometryn 7. Pyridate 8. Trifluralin
Sample volume	50 mL
Mobile phase	Petroleum benzene 40-60°C / acetone 70/80
Detection	UV 254 nm

RP-modified silica plates (TLC and HPTLC)

Free choice of solvent system for special separations & HPLC pilot method

RP-modified silica layers are well suited for many separation problems that cannot be sufficiently solved by unmodified silica.

- Separation of extremely non-polar and highly polar substances using aqueous solvent systems
- Analysis of certain polar substances amenable to ion-pair chromatography, while neutral substances remain constant
- Less dependence on atmospheric humidity

In contrast to unmodified silica, RP phases do not exhibit catalytic activity and are therefore the plates of choice for unstable substances that might tend towards oxidative degradation. Furthermore, RP-modified silica plates provide ready correlation with HPLC columns and allow TLC to be used for method development and as a pilot method for HPLC.

Merck Millipore RP plates RP-2, RP-8 and RP-18 are based on silica gel 60 modified with aliphatic hydrocarbons of increasing hydrocarbon chain length resulting in increased hydrophobicity.

The hydrocarbon chain length in combination with the degree of modification strongly affects retention: Retention of the sample and migration times increases with the higher degree of modification and with growing hydrocarbon chain in the order RP-2, RP-8, RP-18 using the same solvent composition, while RF values decrease. Additionally, with rising water content in the solvent system, retention will increase.

The RP-2 sorbent exhibits higher polarity and high affinity with aqueous solutions tolerating up to 80% water while the longer carbon chains RP-8 and R-18 can be run with up to 60% and 40% water, respectively, in the solvent system.

The special **HPTLC RP-18 W** with a defined lower degree of surface modification can be wetted and developed even with pure water.

The **RP-18 silica plates with concentrating zone** are especially suited for the high-resolution separation of polycyclic aromatic hydrocarbons (PAH).

Ordering information – TLC RP-modified silica gel 60, glass backed

Product	Ordering No.	Format [cm]	Contents of one package
Silica gel 60 RP-2 (silanized)	1.05746.0001	20 x 20	25 plates
Silica gel 60 RP-2 F ₂₅₄ (silanized)	1.05747.0001	20 x 20	25 plates
Silica gel 60 RP-8 F _{254s}	1.15388.0001	20 x 20	25 plates
	1.15424.0001	10 x 20	50 plates
	1.15684.0001	5 x 10	25 plates
Silica gel 60 RP-18 F _{254s}	1.15389.0001	20 x 20	25 plates
	1.15423.0001	10 x 20	50 plates
	1.15683.0001	5 x 20	50 plates
	1.15685.0001	5 x 10	25 plates

F₂₅₄: Green fluorescent indicator | F_{254s}: Blue fluorescent indicator

Ordering information – TLC RP-modified silica gel 60, aluminium backed

Product	Ordering No.	Format [cm]	Contents of one package
Silica gel 60 RP-18 F _{254s}	1.05559.0001	20 x 20	20 sheets
	1.05560.0001	5 x 7.5	20 sheets

F_{254s}: Blue fluorescent indicator

► **Classical silica TLC plates (TLC)** For versatile and reliable routine analysis of a broad range of substances
page 94

► **High performance silica plates (HPTLC)** For fast analysis of complex samples for manual or instrumental use
page 99

► **Concentrating zone plates (TLC, HPTLC, PLC)** Quick and easy sample application even of large volumes of diluted samples
page 112

Ordering information – HPTLC RP-modified silica gel 60, glass backed

Product	Ordering No.	Format [cm]	Contents of one package
HPTLC silica gel 60 RP-2 F _{254s}	1.13726.0001	10 x 10	25 plates
HPTLC silica gel 60 RP-8 F _{254s}	1.13725.0001	10 x 10	25 plates
HPTLC silica gel 60 RP-18	1.05914.0001	20 x 10	25 plates
HPTLC silica gel 60 RP-18 W	1.14296.0001	20 x 10	25 plates
HPTLC silica gel 60 RP-18 F _{254s}	1.13724.0001	10 x 10	25 plates
HPTLC silica gel 60 RP-18 F ₂₅₄	1.16225.0001	10 x 20	50 plates
HPTLC silica gel 60 RP-18 W	1.13124.0001	10 x 10	25 plates
F _{254s}			

F₂₅₄: Green fluorescent indicator | F_{254s}: Blue fluorescent indicator | Layer thickness: 200 µm | W: Fully wettable with water (can be used even with 100% water in solvent system)

Separation of gallic acid and esters on HPTLC silica RP-18 WF₂₅₄

Sample	1. Dodecyl gallate 2. Butyl gallate 3. Ethyl gallate 4. Methyl gallate 5. Gallic acid
Sample volume	200 nl
Mobile phase	1 N acetic acid / methanol (70+30)
Migration distance	5 cm
Detection	UV 265 nm (TLC/HPTLC Scanner, Camag)



RP-modified silica plates are especially suited for the analysis of basic or acids substances as demonstrated by the good separation of gallic acid and its esters on HPTLC silica RP-18 WF₂₅₄.

RP-modified silica plates (TLC and HPTLC)

Application of RP-modified silica plates

RP-plates significantly broaden TLC applications and can be used for separation of amides, antibiotics, fatty acids:

A. HPTLC silica gel 60 RP-2

B. HPTLC silica gel 60 RP-8

C. HPTLC silica gel 60 RP-18

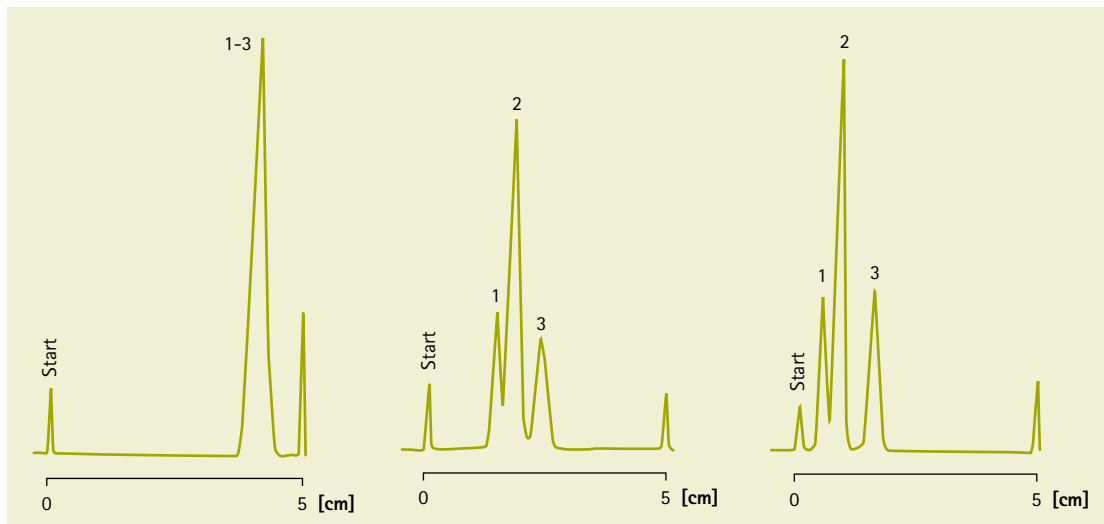

Influence of the hydrocarbon chain length on retention: Retention increases with growing hydrocarbon chain.

Comparison of RP-modified silica plates

Sample	1. Indeno-(1,2,3-c,d)pyrene	0.05%
	2. 3,4-Benzfluoranthene	0.05%
	3. Fluoranthene	0.05%
Sample volume	100 nl	
Mobile phase	Acetonitrile - water (90+10)	
Migration distance	5 cm	
Detection	UV 366 nm (TLC/HPTLC Scanner, Camag)	
Chamber	Normal chamber without saturation	



CN-, Diol- and NH₂-modified plates (TLC and HPTLC)

For special separation problems

CN-, Diol- and NH₂-modified silica sorbents are less polar than the classical silica phases and therefore well suited for separation of hydrophilic or charged substances.

The CN-modified plate is based on a silica gel 60 modified with a cyanopropyl group while the diol-modified plate utilizes a silica surface modified by a vicinal diol alkyl ether. These moderately polar plates with their intermediate properties fill a gap in the range of the silica plates allowing use in both normal phase and reversed phase systems. Due to their special features, all kinds of solvent systems can be used.

Especially the dual personality of the silica-CN plate allows unique two-dimensional separations to be achieved by using the normal phase mechanism in the first direction followed by the reversed phase mechanism in the second direction.

The amino-modified silica NH₂ plates provide weak basic ion exchange characteristics. These unique features enable the separation of charged compounds such as nucleotides, purines, pyrimidines, phenols and sulfonic acids using simple eluent mixtures. In addition, NH₂ modified silica plates allow for reagent-free detection of certain chemical substances by thermochemical fluorescence activation.

Because most substance separated on these modified plates are colorless, our modified plates contain the blue fluorescing, acid stable UV indicator F_{254s}*. Samples which absorb short-wave UV at 254 nm are detected due to fluorescence quenching.

Ordering information – TLC modified silica gel 60, aluminium backed

Product	Ordering No.	Format [cm]	Contents of one package
Silica gel 60 NH ₂ F _{254s}	1.05533.0001	20 x 20	20 sheets

F_{254s}*: Blue fluorescent indicator

Ordering information – TLC modified silica gel 60, glass backed

Product	Ordering No.	Format [cm]	Contents of one package
HPTLC silica gel 60 CN F _{254s}	1.16464.0001	10 x 10	25 plates
HPTLC silica gel 60 Diol F _{254s}	1.12668.0001	10 x 10	25 plates
HPTLC silica gel 60 Diol F _{254s}	1.05636.0001	20 x 10	25 plates
HPTLC silica gel 60 NH ₂	1.12572.0001	20 x 10	25 plates
HPTLC silica gel 60 NH ₂ F _{254s}	1.13192.0001	20 x 10	25 plates
HPTLC silica gel 60 NH ₂ F _{254s}	1.15647.0001	10 x 10	25 plates

Layer thickness: 200 µm | F_{254s}*: Blue fluorescent indicator

► **Classical silica TLC plates (TLC)** For versatile and reliable routine analysis of a broad range of substances
page 94

► **High performance silica plates (HPTLC)** For fast analysis of complex samples for manual or instrumental use
page 99

Applications of CN-, Diol- and NH₂-modified silica

CN-, Diol- and NH₂-modified plates provide additional selectivities for a wide range of applications including:

- CN-silica: benzodiazepine derivatives, pesticides, plasticizers, tetracyclines, antibiotics, gallic acid esters and others.
- Diol-silica: glycosides, anabolic steroids, aromatic amines and particularly dihydroxybenzoic acids.
- NH₂-silica: charged compounds, such as nucleotides, phenols and sulfones.

Separation of oligo-nucleotides

Sample	1. ApUpG	0.1%
	2. ApApU	0.1%
	3. ApApC	0.1%
	4. ApApA	0.1%
Sample volume	300 nl	
Mobile phase	Ethanol-water (60/40 v/v) plus 0.2 mM lithium chloride	
Migration distance	7 cm	
Detection	UV 254 nm (TLC/HPTLC Scanner 2)	



Separation of oligo-nucleotides on a HPTLC NH₂-modified silica gel 60 plate

Cellulose TLC and HPTLC

For analysis of polar substances

Cellulose is an organic sorbent that is particularly suitable for the separation of hydrophilic substances by partition chromatography. Merck Millipore's cellulose plates include classical TLC or HPTLC plates for demanding high-performance separations. Classical TLC cellulose layers are based on a microcrystalline cellulose for standard separations, while the HPTLC cellulose layers utilize high-purity rod-shaped microcrystalline cellulose resulting in highly reduced diffusion of analytes for critical high-performance separations.

Cellulose plates are available with or without fluorescent indicator. The fluorescent indicator used is a special fluorescent pigment that is stimulated to intense blue fluorescent remission under long-wave UV light of 366 nm and under short-wave UV light of 254 nm.

These products are not intended for use as in-vitro diagnostics in terms of European Directive 98/79/EC. They are for research purposes only, for investigating in-vitro samples derived from the human body without any medical objective.

Ordering information – TLC cellulose, glass backed

Product	Ordering No.	Format [cm]	Contents of one package
Cellulose	1.05716.0001	20 x 20	25 plates
	1.05730.0001	10 x 20	50 plates
	1.05632.0001	10 x 10	100 plates
Cellulose F	1.05718.0001	20 x 20	25 plates
	1.05728.0001	10 x 20	50 plates

F: Fluorescence indicator with excitation wavelength 254/366 nm

Ordering information – TLC cellulose, aluminium backed

Product	Ordering No.	Format [cm]	Contents of one package
Cellulose	1.05552.0001	20 x 20	25 sheets
	1.05563.0001	500 x 20	1 roll
Cellulose F	1.05574.0001	20 x 20	25 sheets

Layer thickness: 100 µm | F: Fluorescence indicator with excitation wavelength 254/366 nm

Ordering information – TLC cellulose, plastic backed

Product	Ordering No.	Format [cm]	Contents of one package
Cellulose	1.05577.0001	20 x 20	25 sheets
Cellulose F	1.05565.0001	20 x 20	25 sheets

Layer thickness: 100 µm | F: Fluorescence indicator with excitation wavelength 254/366 nm

Ordering information – HPTLC cellulose, glass backed

Product	Ordering No.	Format [cm]	Contents of one package
HPTLC cellulose	1.05786.0001	20 x 10	50 plates
	1.05787.0001	10 x 10	25 plates
HPTLC cellulose F	1.15036.0001	20 x 10	50 plates
	1.15035.0001	10 x 10	25 plates

F: Fluorescence indicator with excitation wavelength 254/366 nm

Ordering information – HPTLC cellulose, aluminium backed

Product	Ordering No.	Format [cm]	Contents of one package
HPTLC cellulose	1.16092.0001	20 x 20	25 sheets

Layer thickness: 100 µm

Application of cellulose TLC and HPTLC

Typical applications of cellulose include the analysis of amino acids, carbohydrates, phosphates, nucleic acids and nucleic acids derivatives.

- Detection of abnormal increases of amino acids in clinical laboratories
- 2-dimensional separations such as amino acid "fingerprints"
- Metabolic studies

Separation of oligo-nucleotides

Sample	1. $(\text{NaPO}_3)_3$ 2. $\text{Na}_5\text{P}_3\text{O}_{10}$ 3. $\text{Na}_4\text{P}_2\text{O}_7$ 4. Na_2HPO_4
Sample volume	250 nl
Mobile phase	dioxane sol. 160 g TCA, 8 mL 25% ammonia in 1 L water; 70/30
Migration distance	7 cm
Detection	586 nm (TLC/HPTLC Scanner, Camag)

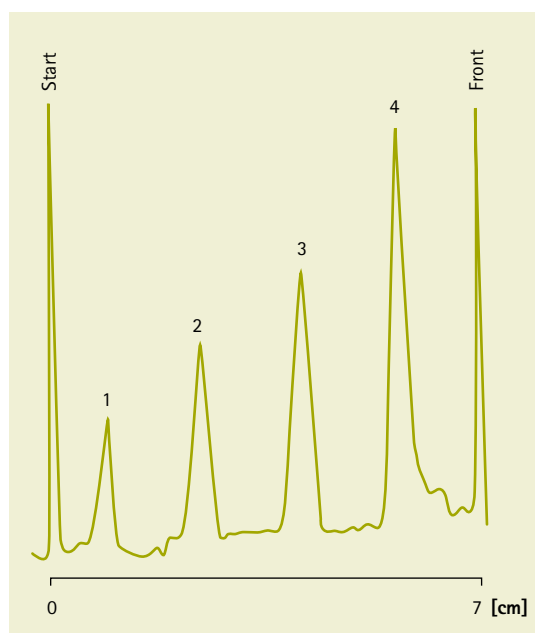

HPTLC cellulose is highly suited to separate polar compounds as demonstrated by the separation of phosphates

PEI (Polyethylenimine) Cellulose

For specific separations by ion-exchange chromatography

PEI Cellulose is polyethylenimine modified cellulose, which acts as a strongly basic anion exchanger. Due to these special characteristics, it is mainly useful to analyze substances with exchange-active groups such as amino acids, peptides and nucleotides or nucleosides.

Ordering information – PEI cellulose TLC, glass & plastic backed

Product	Ordering No.	Format [cm]	Backing	Contents of one package
PEI Cellulose F	1.05725.0001	20 x 20	glass	25 plates
PEI Cellulose F	1.05579.0001	20 x 20	plastic	25 sheets

Layer thickness: 100 µm | PEI cellulose plates should be stored at 0–4°C to reduce deterioration.

Application of PEI (Polyethylenimine) Cellulose

PEI cellulose has specific uses such as the analysis of nucleotides, nucleoside and nucleobases, vanadyl mandelic acid and sugar phosphates.

These products are not intended for use as in-vitro diagnostics in terms of European Directive 98/79/EC. They are for research purposes only, for investigating in-vitro samples derived from the human body without any medical objective.



Analysis of sugar phosphates with PEI cellulose

Concentrating zone plates (TLC, HPTLC, PLC)

Quick and easy sample application even of large volumes of diluted samples

Concentrating zone plates allow easy application of large volumes of diluted samples offering:

- Highly facilitated sample loading
- Better resolution due to uniformly sharp bands
- Includes a purification, sample preparation step

Merck Millipore's concentrating zone plates are based on different adsorption properties of two silica sorbents: a large-pore concentrating sorbent where the samples are applied, and a selective separation layer for the separation. Independent of shape, size or position of the spots, the sample always concentrates within minutes as a narrow band at the interface of the two adsorbents where the separation starts (see figure on page 114).

In addition, the concentrating zone can serve as a clean-up step for complex matrices, e.g. oils, cosmetics. Analytical TLC and HPTLC concentration zone plates provide concentrating areas of 2.5 cm while the concentrating zone of preparative plates (PLC) is 4 cm in width.

The special **HPTLC RP-18 modified silica concentrating zone plate** is optimized for the high-resolution separation of polycyclic aromatic hydrocarbons (PAH) according to DIN 38409-H13. Polycyclic aromatic hydrocarbons (PAH) are derived from organic material by pyrolysis or incomplete combustion. The main sources are the exhaust fumes of private and industrial furnaces, car exhaust and tobacco smoke. Since some PAH are carcinogenic, their determination is of great importance and maximum limits have been set, for example, for drinking water.

Ordering information – TLC concentrating zone plates

Product	Ordering No.	Format [cm]	Backing	Contents of one package
Silica gel 60 concentrating zone 2.5 x 20 cm	1.11845.0001	20 x 20	glass	25 plates
Silica gel 60 concentrating zone 2.5 x 10 cm	1.11844.0001	10 x 20	glass	50 plates
Silica gel 60 concentrating zone 2.5 x 20 cm *	1.05582.0001	20 x 20	aluminium	25 sheets
Silica gel 60 F ₂₅₄ concentrating zone 2.5 x 20 cm	1.11798.0001	20 x 20	glass	25 plates
Silica gel 60 F ₂₅₄ concentrating zone 2.5 x 10 cm	1.11846.0001	10 x 20	glass	50 plates
Silica gel 60 F ₂₅₄ concentrating zone 2.5 x 20 cm *	1.05583.0001	20 x 20	aluminium	25 sheets

Layer thickness: 250 µm / * 200 µm | F₂₅₄: Green fluorescent indicator

► **Classical silica TLC plates (TLC)** For versatile and reliable routine analysis of a broad range of substances
page 94

► **High performance silica plates (HPTLC)** For fast analysis of complex samples for manual or instrumental use
page 99

► **Preparative layer plates (PLC)** For enrichment of target analytes in mg quantities and sample clean-up
page 120

Concentrating zone plates (TLC, HPTLC, PLC)

Ordering information – HPTLC concentrating zone plates

Product	Ordering No.	Format [cm]	Backing	Contents of one package
HPTLC Silica gel 60 concentrating zone 2.5 x 20 cm	1.13749.0001	20 x 10	glass	50 plates
HPTLC Silica gel 60 concentrating zone 2.5 x 10 cm	1.13748.0001	10 x 10	glass	25 plates
HPTLC Silica gel 60 F ₂₅₄ concentrating zone 2.5 x 20 cm	1.13728.0001	20 x 10	glass	50 plates
HPTLC Silica gel 60 F ₂₅₄ concentrating zone 2.5 x 10 cm	1.13727.0001	10 x 10	glass	25 plates
HPTLC Silica gel 60 F ₂₅₄ concentrating zone 2.5 x 5 cm	1.13187.0001	5 x 10	glass	25 plates
HPTLC Silica gel 60 RP-18 F _{254s} concentrating zone 2.5 x 20 cm	1.15498.0001	20 x 10	glass	25 plates
HPTLC Silica gel 60 plate RP-18 concentrating zone 2.5 x 20 cm for PAH detection	1.15037.0001	20 x 10	glass	25 plates

Layer thickness: 200 µm | F₂₅₄: Green fluorescent indicator | F_{254s}: Blue fluorescent indicator

Ordering information – PLC concentrating zone plates, glass backed

Product	Ordering No.	Format [cm]	Layer thickness	Contents of one package
Silica gel 60 F ₂₅₄ concentrating zone 4 x 20 cm	1.13794.0001	20 x 20	0.5 mm	20 plates
	1.13792.0001	20 x 20	1 mm	15 plates
	1.13793.0001	20 x 20	2 mm	12 plates

F₂₅₄: Green fluorescent indicator

Concentrating zone plates (TLC, HPTLC, PLC)

Application

Concentrating zone plates highly facilitate manual sample application, of large or dilute samples.

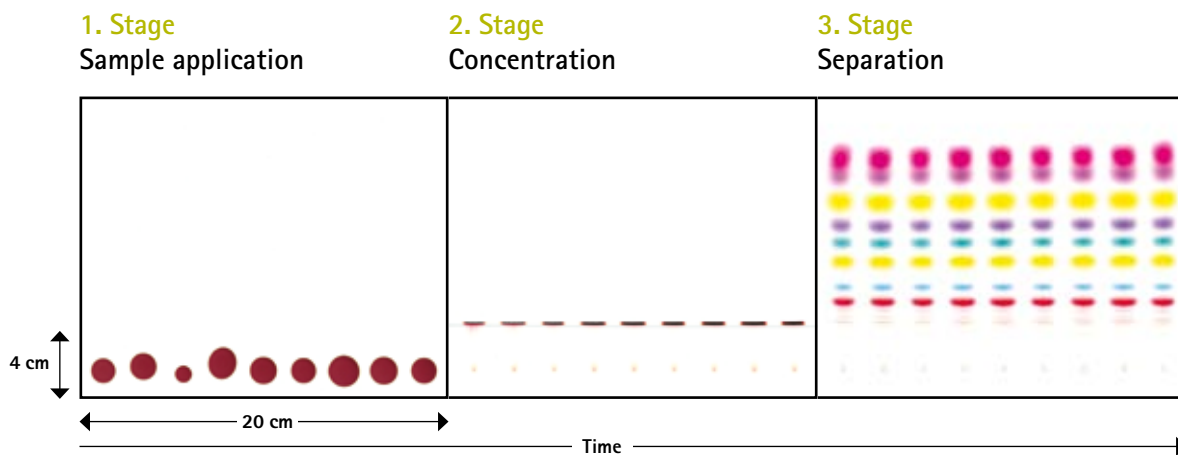

Stages of the development of a PLC concentrating zone plate silica gel 60. Separation of lipophilic dyes with toluene as mobile phase.



ProteoChrom® HPTLC plates

For peptide analysis

The new ProteoChrom® plates have been optimized for highly efficient separations especially for analysis of peptides and protein digests.

- Highly reproducible: optimized separation & staining procedures
- Convenient, easy-to-follow detailed protocols included
- Sensitive: extra thin layers of 100 µm
- Highly stable in water, ideal for use with aqueous solvent systems

ProteoChrom® HPTLC Silica gel 60 F_{254s} plates utilizes an extra thin layer of high-performance Merck Millipore silica gel providing highly efficient separation characteristics for 1-D analysis of peptides and protein digests. Due to the special binder composition, the plates are highly stable in water. Up to 20 peptides can be resolved and as little as 1-2 ng per band can be visualized.

ProteoChrom® HPTLC Cellulose sheets utilize an extra thin layer of optimized microcrystalline cellulose. Specially developed protocols for development and staining enable straightforward 2-D analysis in only 4 hours.

Each ProteoChrom® package includes an insert sheet with detailed instructions for solvent systems, running conditions and staining solution, enabling straightforward experiments without time-consuming optimization work.

The new ProteoChrom® plates open a new application field for Thin Layer Chromatography.

Ordering information – HPTLC LiChrospher® RP-modified silica gel 60

Product	Ordering No.	Format [cm]	Backing	Contents of one package
ProteoChrom® HPTLC silica gel 60 F _{254s}	1.05650.0001	20 x 10	glass	25 plates
ProteoChrom® HPTLC Cellulose	1.05651.0001	10 x 20	aluminium	25 sheets
ProteoChrom® Peptide Staining Kit	1.05655.0001	–	–	–

F_{254s}: Blue fluorescent indicator

2-dimensional HPTLC of single protein digests

A. Fluorescamine staining

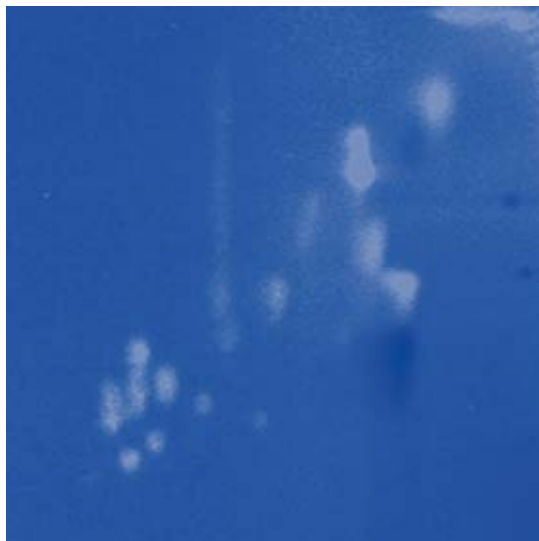

B. Staining with ninhydrin

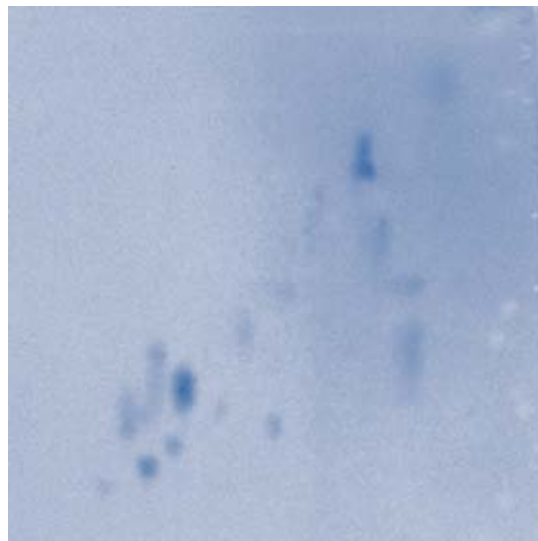

Cytochrome C tryptic digests were 2-D separated on ProteoChrom® HPTLC Cellulose sheet followed by either (A) fluorescamine staining, or (B) staining with ninhydrin.

Cytochrome C tryptic digests 2-D separated on ProteoChrom® HPTLC Cellulose sheet

Sample volume	5 µL
Concentration	2 mg/mL
Application system	Automatic TLC Sampler 4 (CAMAG)
Mobile phases	1st dimension: 2-butanol/pyridine/acetic acid/water (30/20/6/24), 1D 2nd dimension: 2-butanol/pyridine/ammonia (25%) / water (39/34/10/26), 2D
Migration distance	5 cm
Migration time	1st dimension: 44 min 2nd dimension: 50 min
Staining	A: Fluorescamine B: Ninhydrin

1-dimensional separation of single protein digests

A. Fluorescamine staining



B. Staining with ninhydrin



Tryptic digests of various proteins were separated on a ProteoChrom® HPTLC Silica gel 60 F_{254s} plate followed by either (A) fluorescamine staining, or (B) staining with ninhydrin.

Tryptic digests of various proteins separated on ProteoChrom® HPTLC Silica gel 60 F_{254s} plate

Sample volume	A: 1.5 µL
	B: 4 µL
Concentration	2 mg/mL
Application system	Automatic TLC Sampler 4 (CAMAG)
Mobile phases	2-butanol/pyridine/ammonia (25%) / water (39/34/10/26)
Migration distance	5 cm
Migration time	45 min
Staining	A: Fluorescamine
	B: Ninhydrin

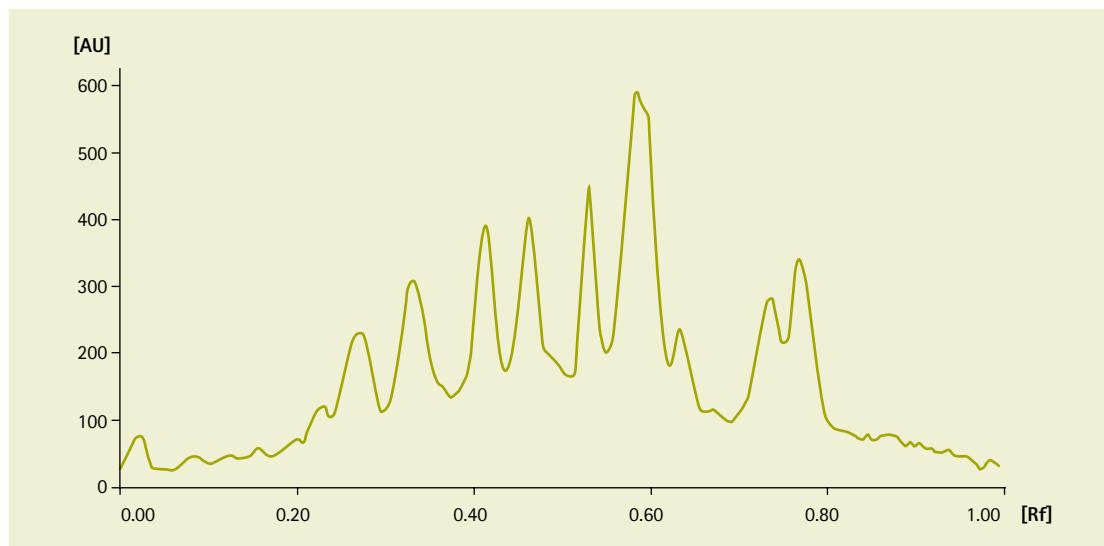

Densitogram of a tryptic digest of b-Casein. A tryptic digest of b-Casein was separated on a ProteoChrom® HPTLC Silica gel 60 F_{254s} plate followed by fluorescamine staining and scanned with a CAMAG TLC Scanner III in fluorescence mode at UV 366.

Multiformat plates (TLC and HPTLC)

Multiple sizes in one single glass plate

Merck Millipore multiformat glass plates are pre-scored for easy snapping with the fingers to smaller sizes.

- Easy snapping with the fingers
- Up to 7 formats in one plate

Multiformat plates utilize the same proven silica coating as the corresponding TLC or HPTLC plate delivering chromatograms that are identical to those on normal non-scored plates.

The number of possible plates depends on the scoring, for example: For a 20 x 20 cm plate scored in segments of 5 x 10 cm, up to seven different formats are possible: 20 cm x 20 cm, 15 cm x 20 cm, 10 cm x 20 cm, 5 cm x 20 cm, 10 cm x 15 cm, 10 cm x 10 cm, 5 cm x 10 cm

Ordering information – Multiformat plates

Product	Ordering No.	Scored [cm]	Number of plates possible	Contents of one package
Multiformat silica gel 60 F ₂₅₄ ex 20 x 20	1.05620.0001	5 x 10	200	25 plates
Multiformat silica gel 60 F ₂₅₄ ex 20 x 20	1.05608.0001	5 x 20	80	20 plates
HPTLC Multiformat silica gel 60 F ₂₅₄ ex 10 x 10	1.05635.0001	5 x 5	100	25 plates
HPTLC Multiformat silica gel 60 ex 10 x 10	1.05644.0001	5 x 5	400	100 plates

F₂₅₄: Green fluorescent indicator

Application of multiformat plates



Note: To prevent the glass backing from uncontrolled and irregular breaking avoid putting plates directly on hot metal plates, drying cabinets or plate heaters after development or staining. When heat drying is necessary, use distance holders of low thermal conductivity between glass and hot metal plate i.e. glass rods or similar.

► **Classical silica TLC plates (TLC)** For versatile and reliable routine analysis of a broad range of substances
page 94

► **High performance silica plates (HPTLC)** For fast analysis of complex samples for manual or instrumental use
page 99

► **Preparative layer plates (PLC)** For enrichment of target analytes in mg quantities and sample clean-up
page 120

GLP plates (TLC and HPTLC)

With individual laser coding for GLP applications

Laser coded GLP plates have been specifically developed for working according to GLP.

The plates carry item, batch and individual plate number on the top of every single plate enabling for convenient back tracing of article, batch, and individual plate number. Every plate can easily be documented and archived.

Based on the same proven Merck Millipore silica as TLC or HPTLC, GLP plates provide the same unsurpassed separation performance as the corresponding TLC or HPTLC plates. GLP coded plates are available as TLC or HPTLC grade in various formats, without or with fluorescence indicator F_{254} that is stimulated to green emission at 254 nm.

Ordering information – GLP plates, glass backed

Product	Ordering No.	Format [cm]	Contents of one package
TLC GLP silica gel 60 F_{254} ¹⁾	1.05566.0001	20 x 20	25 plates
	1.05702.0001	10 x 20	25 plates
HPTLC GLP silica gel 60 F_{254}	1.05564.0001	10 x 10	25 plates
HPTLC GLP silica gel 60	1.13326.0001	10 x 20	25 plates
HPTLC GLP silica gel 60 F_{254}	1.05613.0001	10 x 20	25 plates

1) Layer thickness: 250 μm | F_{254} : Green fluorescent indicator

Laser coded GLP plates

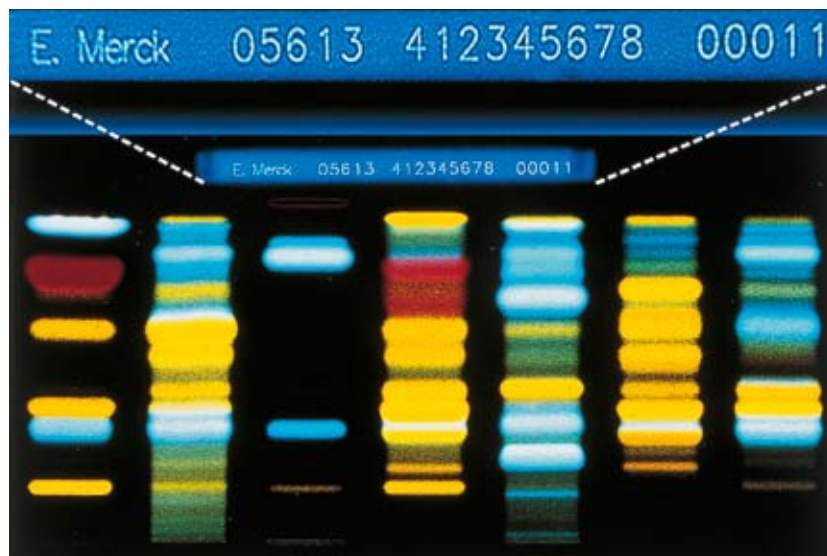

GLP-Plate with additional information

Preparative layer plates (PLC)

For enrichment of target analytes in mg quantities and sample clean-up

Preparative Thin Layer Plates (PLC) allow the separation of mg up to gram samples using up to 2 mm thick layers. PLC plates are based on the same proven Merck Millipore silica binder technology as analytical TLC plates. Merck Millipore's preparative plates are available with layers of silica gel, RP-18-modified silica or aluminium oxide in several layer thicknesses, ranging from 0.5 mm to 2 mm with or without fluorescent indicator.

In PLC, samples are typically applied as a band across the whole width of the plate and substances are visualised almost exclusively by UV detection. The substance can be isolated by extraction after the spot has been scraped from the layer. Just as in analytical TLC, PLC plates with concentration zone highly facilitate sample application.

PLC plates are highly suitable for a variety of preparative applications including: Cleaning and enrichment of synthetic reaction mixtures, natural products, plant extracts and biotechnological products.

Ordering information – PLC silica gel 60, glass backed

Product	Ordering No.	Format [cm]	Layer thickness	Contents of one package
PLC silica gel 60	1.13894.0001	20 x 20	0.5 mm	20 plates
	1.05745.0001	20 x 20	2 mm	12 plates
PLC silica gel 60 F ₂₅₄	1.05744.0001	20 x 20	0.5 mm	20 plates
	1.13895.0001	20 x 20	1 mm	15 plates
	1.05717.0001	20 x 20	2 mm	12 plates
PLC silica gel 60 F ₂₅₄ + F ₃₆₆	1.05637.0001	20 x 20	2 mm	20 plates

F₂₅₄: Green fluorescent indicator

Ordering information – PLC RP-modified silica gel 60, glass backed

Product	Ordering No.	Format [cm]	Layer thickness	Contents of one package
PLC silica gel 60 RP-18 F _{254s}	1.05434.0001	20 x 20	1 mm	15 plates

F_{254s}: Blue fluorescent indicator

Ordering information – PLC aluminium oxide 60, glass backed

Product	Ordering No.	Format [cm]	Layer thickness	Contents of one package
PLC aluminium oxide 60 F ₂₅₄	1.05788.0001	20 x 20	1.5 mm	12 plates

F₂₅₄: Green fluorescent indicator

Ordering information – PLC aluminium oxide 150, glass backed

Product	Ordering No.	Format [cm]	Layer thickness	Contents of one package
PLC aluminium oxides 150 F ₂₅₄	1.05726.0001	20 x 20	1.5 mm	12 plates

F₂₅₄: Green fluorescent indicator

Loose sorbents for preparation of TLC plates

Standardized sorbents for reliable results

Silica gel 60 sorbent is the most versatile and successful material used in Thin Layer Chromatography. Different grades of silica gel 60 sorbents with a particle size of 5-40 µm are offered: silica with gypsum as binder, silica without any foreign binder, and silica gel with fluorescence indicator to suit a broad range of TLC and PLC needs. In addition, high quality aluminium oxide, cellulose microcrystalline and kieselguhr are offered.

Self-coating of layers is time consuming and requires experimental experience for high quality results. For classical TLC, particularly for quantitative work we highly recommend the use of pre-coated plates.

Ordering information – Silica gel 60 for TLC and PLC plates (particle size 5 – 40 µm)

Product	Ordering No.	Package	Contents of one package	Method
Silica gel 60 G	1.07731.1000	Plastic	1 kg	Classical TLC
	1.07731.5000	Tin	5 kg	
	1.07731.9025	Tin	25 kg	
Silica gel 60 G F ₂₅₄	1.07730.1000	Plastic	1 kg	Classical TLC
	1.07730.5000	Tin	5 kg	
	1.07730.9025	Tin	25 kg	
Silica gel 60 G F ₂₅₄ *	1.11678.1000	Plastic	1 kg	TLC
Silica gel 60 H	1.07736.1000	Plastic	1 kg	TLC
	1.07736.2500	Tin	2.5 kg	
	1.07736.9025	Tin	25 kg	
Silica gel 60 H *	1.11695.1000	Plastic	1 kg	TLC
Silica gel 60 H F ₂₅₄	1.07739.1000	Plastic	1 kg	TLC
	1.07739.2500	Tin	2.5 kg	
	1.07739.9025	Tin	25 kg	
Silica gel 60 H F ₂₅₄ + F ₃₆₆	1.07741.1000	Plastic	1 kg	TLC
Silica gel 60 P F ₂₅₄	1.07747.1000	Plastic	1 kg	PLC
	1.07747.2500	Tin	2.5 kg	
	1.07747.9025	Tin	25 kg	
Silica gel 60 P F ₂₅₄ + F ₃₆₆	1.07748.1000	Plastic	1 kg	PLC
	1.07748.2500	Tin	2.5 kg	
Silica gel 60 P F ₂₅₄ with gypsum	1.07749.1000	Plastic	1 kg	PLC
	1.07749.2500	Tin	2.5 kg	
	1.07749.9025	Tin	25 kg	

* Mean particle size 15 µm | F₂₅₄: Green fluorescent indicator | H: Without foreign binder | G: With gypsum | P: For preparative work

Loose sorbents for preparation of TLC plates

Ordering information – Aluminium oxides for TLC and PLC (particle size 5 – 40 µm)

Product	Ordering No.	pH of 10% aqueous suspension	Package	Contents of one package	Method
Aluminium oxide 60 G neutral	1.01090.2500	7.5	Plastic	2.5 kg	TLC
	1.01090.9025	7.5	Plastic	25 kg	TLC
Aluminium oxide 60 G F ₂₅₄ neutral	1.01092.0500	7.5	Plastic	500 g	TLC

F₂₅₄: Green fluorescent indicator

Ordering information – Other sorbents for TLC

Product	Ordering No.	Particle size	Package	Contents of one package
Cellulose microcrystalline	1.02330.0500	< 20 µm	Plastic	500 g



Accessories

TLC Sprayer Accessories

Even and very finely dispersed spray solution is a prerequisite for optimal staining of TLC plates to visualize colorless substances. The Merck Millipore TLC sprayer allows spraying derivatization reagents homogeneously onto the developed chromatograms to detect colorless substances. It is equipped with two different spray heads of 0.8 mm and 1.25 mm optimized for low- and for high-viscosity solutions respectively. The electro-pneumatically operated sprayer uses compressed air driven by accumulator power and inductive charging.

Our ready-to-use spray solutions come in special 100 mL packages that can be screwed directly to the sprayer, eliminating cumbersome pouring of the solutions.

Spray solution

The three most common spray solutions used in TLC are offered as ready-to-use solutions optimally packaged to fit directly onto the sprayer.

UV lamp

Two UV lamps powered by five 1.5 V baby cells (UM2) are intended for the quick detection of substances under short- or long-wavelength UV light.

Ordering information – Accessories and auxiliaries

Product	Ordering No.	Contents of one package
Micro capillaries 2.0 µl	1.10290.0001	50 capillaries
UV lamp 254 nm	1.12537.0001	1 unit
UV lamp 366 nm	1.13203.0001	1 unit
TLC sprayer with two spray heads	1.08540.0001	1 unit
Spray heads for TLC sprayer	1.08541.0001	6 pieces: 5 x 0.8 mm bore / 1 x 1.25 mm bore
Glass bottles 50 mL	1.10647.0001	10 bottles
Glass bottles 100 mL	1.10646.0001	10 bottles

Ordering information – Ready-to-use spray solutions

Product	Ordering No.	Solvent	Package	Contents of one package
Dragendorff-Reagent	1.02035.0100	Acetic acid/ethyl acetate/water	glass	100 mL
Molybdato-phosphoric acid	1.00480.0100	2-propanol	glass	100 mL
Ninhydrin	1.06705.0100	2-propanol	glass	100 mL

Technical appendix

TLC performance is essentially determined by the stationary phase (e.g. silica, cellulose, ...) and the mobile phase. Optimal chromatograms can be obtained by variation of these parameters.

Selection of separation conditions

The triangle scheme according to Stahl provides a basic tool for the selection of separation conditions for adsorption (A) and for partition chromatography (B): rotating one selected parameter at the applicable position automatically defines the other parameters.

Scheme for determination of suitable chromatographic separation conditions

Adsorption

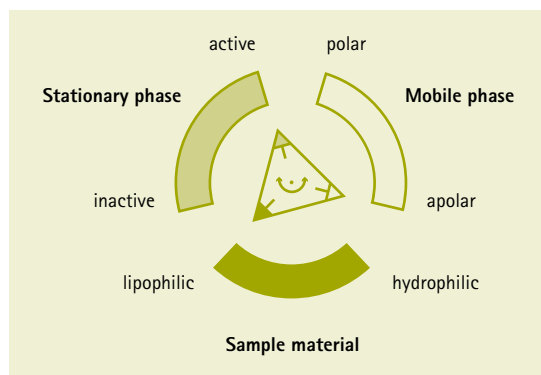

Partition

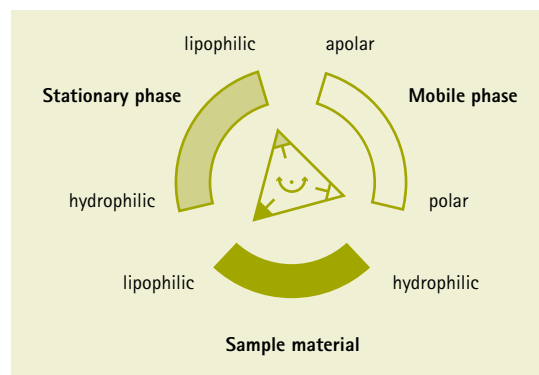

The eluotropic series of solvents, where the solvents are listed in order of increasing elution power, is helpful for choosing a suitable mobile phase for a particular separation problem. The following table lists an eluotropic series for silica gel as stationary phase (eluotropic series for silica gel acc. to Halpaap).

Sample application

Samples can be applied as spots or narrow bands. In both cases their size and width will influence the separation. As a general rule, samples should be applied as narrow as possible. Manual application is achieved with capillaries or a pipette. For large samples volumes, concentrating zone plates will highly facilitate sample application. For quantitative work, semi-automated or automated sample application is recommended for reliable, reproducible results.

Influencing parameters

Solvent	Polarity index acc. to Snyder	Dielectric constant DK [20 resp. 25°C]	Molar mass [g/mol]	Boiling point [°C]	Vapor pressure [20 °C/mbar]	MAK value 1994* [mL/m ³ = ppm]
n-Heptane	-	1.9	100.21	98.4	48	500
n-Hexane	0.0	1.9	86.18	68.9	160	50
Cyclohexane	0.0	2.0	84.16	80.7	104	300
Isooctane	0.4	1.9	114.23	99.2	51	500
1,1,2-Trichlorotrifluoroethane	-	2.4	187.38	47.7	368	500
Carbon Tetrachloride	1.7	2.2	153.82	76.5	120	10
Toluene	2.3	2.4	92.14	110.6	29	100
tert-Butyl methyl ether	2.9	-	88.15	55.2	417	-
Chloroform	4.4	4.8	119.38	61.7	210	10
Dichloroethane	3.7	10.6	98.97	83.4	87	5
Dichloromethane	3.4	9.1	84.93	40.0	453	100
1-Butanol	3.9	17.8	74.12	117.2	6.7	100
Acetonitrile	6.2	37.5	41.05	81.6	97	40
2-Propanol	4.3	18.3	60.10	82.4	43	400
Ethyl acetate	4.3	6.0	88.10	77.1	97	400
Acetone	5.4	20.7	58.08	56.2	233	1000
Ethanol	5.2	24.3	46.07	78.5	59	1000
1,4-Dioxane	4.8	2.2	88.11	101.0	41	50
Tetrahydrofuran	4.2	7.4	72.11	66.0	200	200
Methanol	6.6	32.6	32.04	65.0	128	200
Water	9.0	80.2	18.01	100.0	23	-

* BIA-Report 1/94

Other parameters influencing performance

TLC is usually carried out in an open separation system and a variety of further factors influence the quality of the result.

Main factors are:

- Sample application
- Relative humidity
- Layer reproducibility
- Impurities of the solvent

Humidity

TLC plates, especially the widely used unmodified silica sorbent, adsorb water. Changes in relative humidity can effect a number of important factors e.g. Rf values, selectivity, solvent front migration and the position of multiple fronts. The relative humidity of the atmosphere is therefore critical for reproducible work. If constant humidity can not be assured, we suggest pre-conditioning the plates for 30 min over saturated salt solutions or sulphuric acid solutions of defined concentration. Relative humidity above selected salt solutions is given in Table.

TLC plates

Saturated salt solution containing a large quantity of undissolved salt	Relative humidity above solution [20°C / %]
di-Sodium hydrogenphosphate $\text{Na}_2\text{HPO}_4 \cdot 12 \text{H}_2\text{O}$	95
Sodium carbonate $\text{Na}_2\text{CO}_3 \cdot 10 \text{H}_2\text{O}$	92
Zinc sulfate $\text{ZnSO}_4 \cdot 7 \text{H}_2\text{O}$	90
Potassium chloride KCl	86
Ammonium sulfate $(\text{NH}_4)_2\text{SO}_4$	80
Sodium chloride NaCl	76
Sodium chlorate NaClO_3	75
Sodium nitrite NaNO_2	65
Ammonium nitrate NH_4NO_3	63
Calcium nitrate $\text{Ca}(\text{NO}_3)_2 \cdot 4 \text{H}_2\text{O}$	55
Sodium dichromate $\text{Na}_2\text{Cr}_2\text{O}_7 \cdot 2 \text{H}_2\text{O}$	52
Potassium carbonate K_2CO_3	45
Zinc nitrate $\text{Zn}(\text{NO}_3)_2 \cdot 6 \text{H}_2\text{O}$	42
Chromium trioxide CrO_3	35
Calcium chloride $\text{CaCl}_2 \cdot 6 \text{H}_2\text{O}$	32
Potassium acetate $\text{K}(\text{OOCCH}_3)$	20
Lithium chloride $\text{LiCl} \cdot \text{H}_2\text{O}$	15

Thin Layer Chromatography and Pharmacopeias (Ph Eur, BP, USP, DAB)

Traditionally some TLC monographs in a pharmacopeia refer to TLC products using silica G containing gypsum as binder or silica H without any foreign binder.

Pre-coated plates without binder or with gypsum have a very fragile surface and cannot be packed and transported without distortion of the layer. Therefore G and H plates are not generally available commercially; G-plates are now available from Merck Millipore. Please ask your local Merck Millipore representative for further information.

Merck Millipore plates contain an organic binder that was especially chosen to cause as few chromatographic deviations as possible in comparison to sorbents containing G or H.

There is no restriction by Ph Eur on the use of pre-coated plates containing other organic binders than G or H, presuming the chromatographic results are comparable to the results obtained with "G" or "H" plates. The latter has to be confirmed individually.

Thin Layer Chromatography Publications

The following publications, available in German only, feature Ph Eur monographs for pre-coated TLC plates:

P. Pachaly: "DC-Atlas – Dünnschicht-Chromatographie in der Apotheke", Wissenschaftliche Verlagsgesellschaft Stuttgart 1999, ISBN 3-8047-1623-7. Includes many documented Ph Eur monographs for Merck Millipore TLC plates.

Jürgen Wolf: Mikro-DC, PZ-Schriftenreihe, "Vorschriften auf Basis des Ph Eur, DAB und DAC". Govi-Verlag, Eschborn 1999, ISBN 3-7741-0736-X. This book features a broad range of Ph Eur monographs for Merck Millipore TLC aluminium sheets Si 60.



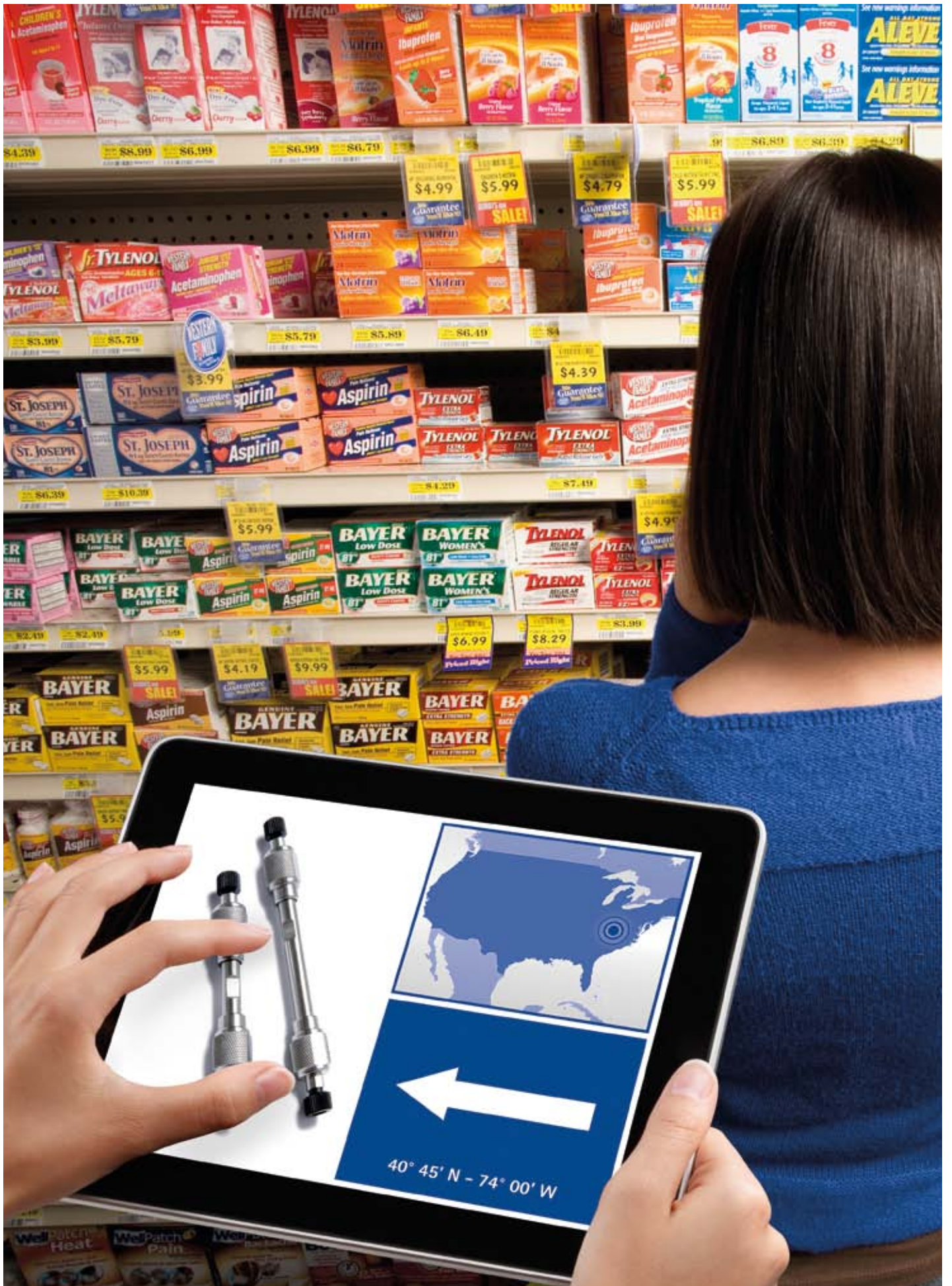

Analytical HPLC

We arrive at a crossroads. One that is familiar to all of us as consumers. In a world that is fighting for our attention: whom should we trust? The answer becomes even more important when selecting medication. One wrong decision could have potentially harmful consequences, as well as destroy a brand's reputation. Needless to say, quality control is of utmost importance in pharmaceuticals, chemicals, and food and beverage production. To help guarantee the safety of your products, Merck Millipore offers an extensive range of high-quality analytical HPLC solutions as well as application support. Thanks to our experience and uncompromising standards, Merck Millipore has become a most reliable name in HPLC technology. Together we can ensure health and built trust.

04

Contents

Analytical HPLC	page 134
-----------------	----------

Method development & optimization	page 136
-----------------------------------	----------

Column selection guide	page 152
------------------------	----------

Chromolith® Speed and performance based on revolutionary monolithic silica technology	page 160
------------------------------------------------------------------------------------------	----------

Chromolith® CapRod® Monolithic capillary	page 161
---------------------------------------------	----------

Chromolith® HPLC columns Speed and performance in monolithic form	page 166
----------------------------------------------------------------------	----------

Chromolith® RP-18 endcapped Chromolith® RP-18 endcapped columns are the fastest C18 columns in the world.	page 172
--------------------------------------------------------------------------------------------------------------	----------

Chromolith® RP-8 endcapped	page 188
----------------------------	----------

Chromolith® Si	page 190
----------------	----------

Chromolith® NH ₂	page 192
-----------------------------	----------

Chromolith® guard cartridges and cartridge kits	page 195
-------------------------------------------------	----------

Chromolith® column coupler	page 198
----------------------------	----------

Chromolith® SemiPrep Perfect scale-up from analytical to preparative LC	page 200
----------------------------------------------------------------------------	----------

Chromolith® Prep Chromolith® – increase in speed, efficiency and productivity	page 204
----------------------------------------------------------------------------------	----------

Purospher® The all-around high performance solution for complex HPLC separations	page 212
Purospher® STAR RP-18 endcapped The versatility you need!	page 219
Purospher® STAR columns for LC/MS applications	page 232
Purospher® STAR UHPLC columns for ultra fast HPLC Where speed meets performance	page 234
Purospher® STAR RP-8 endcapped Optimized for more polar compounds	page 236
Purospher® STAR Si (Silica) and NH ₂ (Amino-phase)	page 238
Purospher® RP-18 endcapped Excellent peak symmetry with either basic or strongly acidic compounds	page 240
Purospher® RP-18 Accelerate and simplify method development for basic compounds	page 242
Purospher® RP-18 HC High resolution separation of explosives and related compounds	page 244
Superspher® Silica carrier for highly efficient separations	page 246
Superspher® For highly efficient HPLC of complex mixtures where high peak capacity required	page 248



04

LiChrospher® Silica carrier for constant top-rate results	page 250
LiChrospher® 100 RP-18 and RP-18 endcapped	page 252
LiChrospher® WP 300 RP-18 High-resolution separations of peptides and tRNA molecules	page 256
LiChrospher® PAH Indispensable in PAH trace analysis	page 258
LiChrospher® 100 RP-8 and RP-8 endcapped For reproducible reversed phase separation	page 261
LiChrospher® 60 RP-select B Excellent separations even with basic compounds	page 264
LiChrospher® 100 CN Excellent for complex samples with polar and hydrophobic characteristics	page 268
LiChrospher® 100 NH ₂ A versatile sorbent for both reversed phase and normal phase chromatography	page 269
LiChrospher® 100 DIOL Excellent for complex samples with polar and hydrophobic characteristics and for exclusion chromatography	page 270
LiChrospher® Si 60 and Si 100	page 271
LiChrosorb® Irregular shaped silica sorbent	page 272
LiChrosorb® A successful packing material from the start	page 273
Aluspher® Alkaline stable HPLC separations	page 275
Aluspher® RP-select B A stable reversed phase stationary phase optimized for applications up to pH 12	page 276

SeQuant® ZIC®-HILIC and ZIC®-pHILIC The ideal columns for all classes of polar and hydrophilic compounds	page 278
SeQuant® ZIC®-HILIC High-performance columns for hydrophilic compounds	page 282
SeQuant® ZIC®-pHILIC Polymeric columns with extended pH stability for demanding separations of hydrophilic compounds	page 287
Chiral stationary phases Always the proper column for enantiomer analysis	page 288
ChiraDex® Specially for the separation of enantiomers	page 290
Customized packings	page 292
Customized packings Always the right column	page 293
Accessories	page 296
manu-CART® cartridge holder for LiChroCART® cartridges Accessories for particulate HPLC columns	page 296
LiChroCART® cartridge Accessories for particulate HPLC columns	page 299
Hibar® column Accessories for particulate HPLC columns	page 301
LiChroTest® Standard samples for HPLC system qualification	page 306
Column care and use	page 308
Trouble-Shooting	page 316

Analytical HPLC

Introduction

Analytical HPLC is routinely used in industry and academia for separation, quantitation and identification of chemical or biological compounds.

Merck Millipore has invested decades into product innovation to ensure the most reliable and reproducible HPLC separations, even for the most challenging analyses. As a result, we offer a comprehensive range of high-quality HPLC columns for use in research, development and quality control, as well as in environmental, clinical and biochemical analyses.

Thanks to their unique, patented, monolithic silica technology, our **Chromolith®** columns allow you to perform ultra-fast and robust separations using standard HPLC systems. For all polar and hydrophilic compounds, the proprietary zwitterionic **SeQuant® ZIC®-HILIC** technology provides straightforward HPLC separations with high flexibility in the selection of separation conditions. The optimally balanced selectivity of **Purospher®** makes it the perfect choice for reversed phase HPLC and UHPLC method development in a wide variety of labs. Merck Millipore's well-established HPLC column brands, **LiChrosorb®**, **LiChrospher®** and **Superspher®**, continue to provide excellent results. In addition, we have developed specialty columns for the separation of chiral compounds, an important application in the pharmaceutical industry.



Analytical HPLC at a glance

Method development & optimization	page 136
Column selection guide	page 152
Chromolith® Speed and performance based on revolutionary monolithic silica technology	page 160
Purospher® The all-around high performance solution for complex HPLC separations	page 212
Superspher® Silica carrier for highly efficient separations	page 246
LiChrospher® Silica carrier for constant top-rate results	page 250
LiChrosorb® Irregular shaped silica sorbent	page 272
Aluspher® Alkaline stable HPLC separations	page 275
SeQuant® ZIC®-HILIC and ZIC®-pHILIC The ideal columns for all classes of polar and hydrophilic compounds	page 278
Chiral stationary phases Always the proper column for enantiomer analysis	page 288
Customized packings	page 292
Accessories	page 296
Column care and use	page 308
Trouble-Shooting	page 316

Method development & optimization

The overall process is influenced by the nature of the analytes and generally follows the following steps:

- 1 | Selection of the HPLC method and system
- 2 | Establish sample prep procedure
- 3 | Select detector
- 4 | Selection of initial conditions
- 5 | Perform preliminary separations
- 6 | Selectivity optimization
- 7 | System optimization
- 8 | Method validation

1 Selection of the HPLC method and system

Method development is not difficult when a literature reference can be found to same or similar needs. Methods are published in pharmacopeia, in column manufacturer application databases and as published scientific studies. This can provide good guidance for the planned work, but what happens when references to the compounds of interest do not exist?

Different approaches are possible, and trial and error is the least successful way forward. A chromatographer normally has access to a wide variety of equipment, columns, mobile phase compositions and operational parameters which make high performance liquid chromatography (HPLC) method development seem complex. In this chapter direction will be given to make your method development intuitive and successful, with emphasis on column selection.

Method goals

Method development is to define needs, set goals, and make experimental plans, then to carry out the practical work and finally validate and put the new method into routine work. For these reasons, method development should be started at the desk, and not in the laboratory. A number of questions should be addressed and answered.

- Is the primary goal quantitative or qualitative analysis?
- If quantitative analysis is requested what levels of accuracy and precision are required?
- Are standards available?
- Do we need to perform detection of one or many analytes?
- Is it necessary to resolve all sample components?
- How many different sample matrices is the method designed for?
- How many samples will be analyzed at one time?
- If qualitative analysis is requested it is important to define whether the method will be used for characterization of unknown sample components or isolation/purification of analytes

These initial questions will direct the chromatographers to define the method goal, and to find out requirements of the new method.

Do you really need high resolution (in separation and detection), short analysis time, maximum sensitivity, long column lifetime, a column with wide pH stability or will the method be used at neutral pH and under non-aggressive conditions. True optimization of a method is a balance between selectivity, speed and efficiency, in order to produce resolution that fits the purpose of the application. Ideally, the development should result in a robust method that gives the laboratory a low overall price-per-injection and ultimately a cost-efficient assay.

Common mistakes in analytical method development

- Inadequate formulation of method goals
- Insufficient knowledge of chemistry
- Use of the first reversed phase HPLC column available
- Use of wrong instrument set-up
- Trial and error with different columns, mobile phases

These mistakes often result in laborious, time consuming projects that lead to methods which fail to meet the needs of the laboratory.

Getting started

After defining the goal of the method development, specific information of the sample and the analytes should be sought. Different sources are available: e.g. scientific journals, chemical databases like www.pubmed.org (small molecules) ExpASY Proteomics Server <http://expasy.org> (large biomolecules) and reference books. Listed below are some of the most common parameters.

- Nature of the sample
- Number of compounds/analytes present
- Chemical structure (functionality)
- Molecular weight of the compounds
- pKa values
- log *P* and/or log *D* values (hydrophilicity/hydrophobicity)
- Concentration
- Sample matrix
- Sample solubility

Depending on the method requirements, some steps will not be necessary. For example, if a satisfactory separation is found initially, steps 6 and 7 may be omitted. The extent to which method validation (step 8) is investigated and pursued will depend on the final use of the analysis; for example, a method required for quality control will require more validation than one developed for a one-off analysis.

Method development & optimization

- 1 | Selection of the HPLC method and system
- 2 | Establish sample prep procedure
- 3 | Select detector
- 4 | Selection of initial conditions
- 5 | Perform preliminary separations
- 6 | Selectivity optimization
- 7 | System optimization
- 8 | Method validation

2 Establish sample prep procedure

Consideration must be given to sample preparation. Does the sample require dissolution, filtration, preconcentration or clean up? Is it possible or needed to use solid phase or liquid-liquid extraction procedures, column switching or any other automated on-line techniques? In the following sections, emphasis will be focussed to reversed phase method development. Guidance will be given also to the other modes of liquid chromatography, for which more information can be found at www.merck-chemicals.com/chromatography.

Finally, remember to keep it simple, and think of factors that are likely to be significant in achieving the desired resolution.

What to do and where to start?

Think about the sample as being the central part during all steps, as illustrated in figure, since HPLC method development should aim at separating analytes from a defined matrix, and at allowing detection with sufficient sensitivity in a rugged and easy way for the analyst.

What to do and where to start?

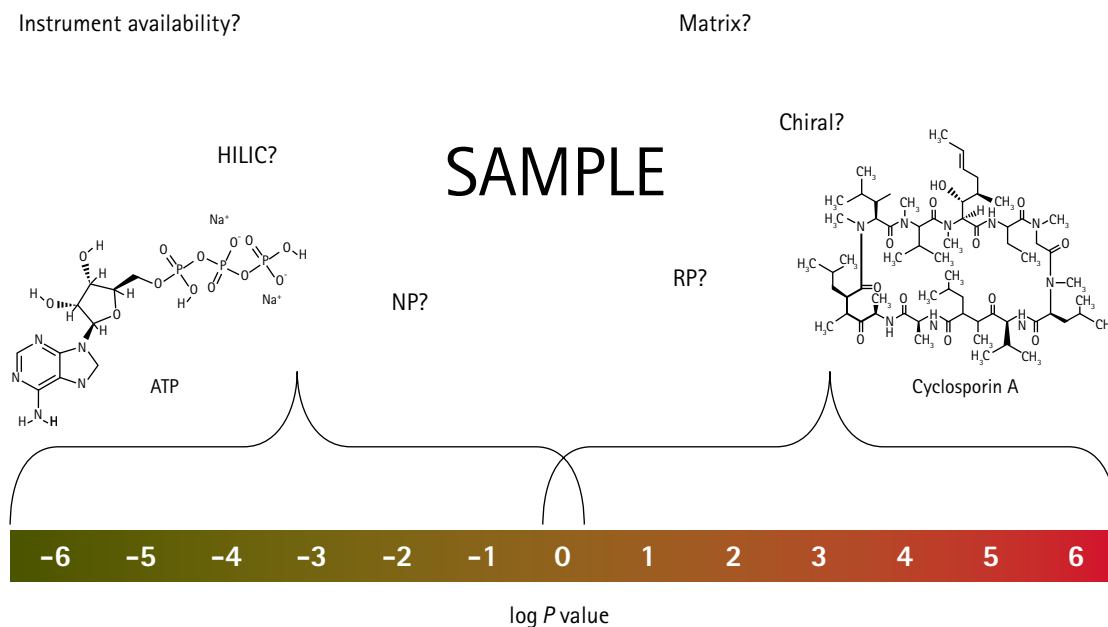

More useful and detailed information can be found in the column selection guide on page 152.

Select the detector

3

To select the most appropriate detection mode, four important parameters should be taken into consideration; chemical nature of the analytes, potential interferences, limit of detection (LOD) and limit of quantitation (LOQ) required, linearity range, availability and/or cost of detector. Below are some of the most common detection techniques for liquid chromatography presented. Fluorescence, electrochemical or mass detectors should be used for trace analysis. For preparative HPLC, refractive index is preferred because it can handle high concentrations without overloading the detector.

Ultraviolet/Visible absorbance (UV/Vis)

UV detectors are most commonly used. It is a robust, inexpensive and versatile detection technique since most compounds absorb light, especially at low UV wavelengths. It is possible to use a Diode Array Detector (DAD) and allow monitoring at multiple wavelengths simultaneously. The downside is that a UV detector is not analyte specific and requires that the analyte absorb more light than sample matrix at the set wavelength. Choose a detection wavelength that maximizes sensitivity and specificity, but keep in mind that the mobile phase solvents and buffer components may cause slight shifts in UV_{max} from reference values. Therefore it is advisable to check the analyte absorbance in the mobile phase. Mobile phase solvents and buffer components also have UV cut-off, and make sure to work well above these levels. Otherwise there are likely to be problems with reduced sensitivity and increased system noise (unstable and drifting baseline noise). UV wavelengths below 200 nm should be avoided because detector noise increases in this region. Higher wavelengths give greater selectivity.

Refractive index (RI)

Refractive index is also a common detection technique, and measures the difference in the refractive index of a sample cell versus a reference cell. It is also a non-selective detection technique, being concentration dependent and where the sensitivity is typically 100–1000 times lower than a UV/Vis detector. The benefit over a UV detector is the possibility to quantify analytes with no chromophores in the molecular backbone. The drawback is the sensitivity and the fact that RI detectors can only be used in isocratic mode. It is possible to use with gradients but requires special modifications which makes it less user friendly.

Fluorescence (FL)

Fluorescence detection is very specific and measures only compounds that fluoresce, hence a requirement of this technique. The operation is similar to a UV/Vis detector but where the detector flow cell is used as the sensor through which excitation light passes axially. A photocell is located at the side of the cell to receive radially emitted light. The cell wall is made of special glass to prevent the excitation light or other stray light from reaching the photo cell. When a solute that fluoresces in the excitation light flows through the cell, the molecule excites and fluorescent light passes through the walls of the cell onto the photo cell. The excitation light may be light of any wavelength selected from the light source using a monochromator. Another monochromator may also be used to selectively analyze the fluorescent light and, thus a fluorescent spectrum can be produced for excitation light of any specific wavelength and an excitation spectrum produced for fluorescent light of any specific wavelength. To improve specificity of an LC analysis, a fluorescent derivatization reagent can be added (either pre-column or post-column) to form a fluorescent derivative of the substance of interest. This derivative may then be selectively detected from other solutes which, (if they do not fluoresce) need not be resolved from each other by the separation column. Fluorescence detection is up to 1000 times more sensitive than UV/Vis, and also concentration sensitive.

Evaporative light scattering (ELS or ELSD)

ELSD is also a non-selective detection technique, but where the detector is mass sensitive and not concentration dependent. It is an ideal technique for high molecular weight compounds, sugars and less volatile acids. The detector measures the light scattering and where the amount of scattering is related to the molecular mass of the analyte, i.e. the more mass the more scattering will be seen measured. In the detector there are three processes; nebulisation of the mobile phase (1), evaporation of the mobile phase (2) and light scattering by analyte particles. In contrast to RI, it works well in gradient mode. Keep in mind that mobile phase solvents should be volatile for best performance.

Electrochemical (EC)

An electrochemical detector requires that the analytes can be oxidised or reduced by an electrical current. The detector output is an electron flow generated by a reaction that takes place at the surface of electrodes. If this reaction is complete (exhausting all the analyte) the current becomes zero and the generated total charge is proportional to total mass of material that has been reacted. This process is called coulometric detection. If the mobile phase is continuously flowing past the electrodes, the reacting analyte is continuously replaced in the detector. As long as the analyte is present between the electrodes, a current will be maintained, albeit varying in magnitude, and is called amperometric detection. An electrochemical detector requires three electrodes, the working electrode (where oxidation or reduction takes place), the auxiliary electrode and the reference electrode (compensates for changes in the background conductivity of the mobile phase). Electrochemical detection is more sensitive than fluorescence detection, very sensitive but commonly not as selective as fluorescence and generally not compatible with gradient elution.

Mass spectrometer (MS)

Mass analyzers can be quadrupole, magnetic sector, time-of-flight, ion trap or ion cyclotron resonance type. Mass spectrometric detection is rapidly growing in popularity, because of ease of use, better compatibility with liquid chromatography and lower costs. The benefits with MS are that it allows for positive analyte identification and the possibility to discriminate between co-eluting peaks in selected ion monitoring mode. The latter reduces the requirement for chromatographic resolution before detection, but it is always better to have completely resolved peaks to prevent ion suppression or ion enhancement effects. To achieve best sensitivity, mobile phases used should be set at a pH where analytes are ionized, and a rule of thumb is to use neutral to basic pH (7–9) for acids whereas more acidic pH (3–4) is advisable for basic compounds. However, depending if the analyte of interest have multiple pKa values and may change its ionization state, other pH values may be more beneficial both in terms of both ionization of the analyte and behaviour in the separation column. A quadrupole mass analyzer consists of four parallel rods that have fixed DC and alternating RF potentials applied to them. Ions produced in the source of the instrument are then focussed and passed along the middle of the quadrupoles. Their movement will depend on the electric fields so that only ions of a particular mass to charge ratio (m/z) will have a stable path to the detector. The RF is varied to bring ions of different m/z into focus on the detector and thus build up a mass spectrum. Quadrupole mass spectrometers commonly have two configurations when used with liquid-chromatography, either as a simple single quadrupole system or placed in tandem. The latter principle, the triple quadrupole mass spectrometer, enables ion fragmentation studies (tandem mass spectrometry or MS/MS) to be performed.

There are other less commonly used detection techniques possible to combine with liquid chromatography, such as chemiluminescence nitrogen (CLND), radio detectors, charged aerosol (CAD), inductive coupled plasma (ICP), NMR, but these are not dealt with here.

4

Selection of initial conditions – mode of separation, column and mobile phase

When selecting the most suitable mode of separation, it is dependent on sample solubility and how the analytes of interest differ from other compounds or matrix in the sample. In reversed phase (RP) mode the mobile phase is polar and the stationary phase is less polar. The major distinction between analytes is their hydrophobicity where samples should be soluble in water or a polar organic solvent. In normal phase (NP), the mobile phase is non-polar while the stationary phase is more polar. This is the same for hydrophilic interaction liquid chromatography (HILIC). In normal phase, the major distinction between analytes is NOT their hydrophobicity, and where the samples should be soluble in a hydrophobic solvent like hexane and the mobile phase is a weak to moderate solvent for the sample.

In HILIC mode, the mobile phases are the same as for reversed phase, but with the opposite elution strength. The major distinction between analytes is their hydrophilicity and the sample should be soluble in a polar organic solvent or organic solvent – water mixtures. For polar and hydrophilic compounds the traditional approach utilized reversed phase ion-pairing and was used for analytes which were ionic or potentially ionic. In this situation the mobile phase contains a buffer, an ion-pair reagent and a polar organic solvent. Typical ion-pair reagents are; alkyl sulfonates (heptane sulfonic acid, octane sulfonic acid) and used for bases; and where quaternary amines (tetrabutylammonium chloride) are used for acids. Today, reversed phase ion-pairing methods can easily be replaced with HILIC with the benefit of having more robust and sensitive methods without the need of using ion-pairing reagent.

Choose the right HPLC column

Chromatographic resolution is mainly affected by the selectivity (α), as can be seen in the figure below. Changing the mobile phase composition or the stationary phase, is the most powerful way of optimizing selectivity whereas the particle size, pore size, length of the column, temperature, mobile phase strength have much less effect. Therefore, if satisfactorily results are not met, or no retention is achieved, it is better to change to another selectivity using a different column type and/or a different mobile phase.

Resolution is mainly controlled by selectivity

Resolution (R_s or R) can be expressed in terms of three parameters (k , α , and N) which are directly related to experimental conditions.

k is the average retention factor for the two bands,
 N is the column plate number and
 α is the separation factor (or selectivity factor).

The parameters k and α is determined by the experimental conditions (composition of the mobile phase; stationary phase chemistry and temperature), and where N is affected by column length, particle size and pore size.

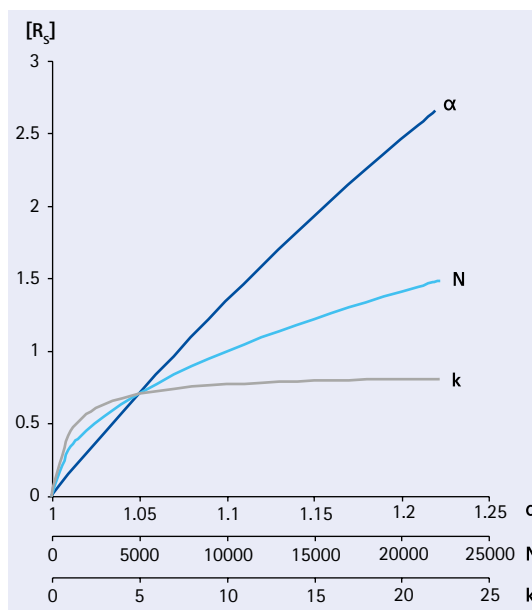

Stationary phase selection

After setting the method goals and careful investigation of the analyte structures (hydrophobicity/hydrophilicity; functional groups and potential detection possibilities), select a few bonded phases fitted for its purpose along with a viable detector. The initial column selection is very important and the chromatographer should be advised not to use the first reversed phase HPLC column available. Reversed phase liquid chromatography is indeed a workhorse in most laboratories, and a particulate RP-18 column is often the first choice for many chromatographers, but many methods are unfortunately developed not utilising best or most appropriate selectivity. If the sample is mainly of hydrophobic character, having positive log *P* values and mainly having hydrophobic functional groups, a reversed phase column is advisable. Select a C18 or C8 bonded phase for good retention and resolution. If the method is intended for bioanalysis, analysis of dirty samples in general, or where proper sample preparation is unwanted/not possible, a monolithic reversed phase column (e.g. Chromolith®) is a superior choice over a particulate column. Chromolith® RP-18e is a better choice over Purospher® STAR RP-18e for such purposes as it has very good matrix tolerability and long column lifetime.

If samples are clean or and/or good sample preparation will be included in the final method, and very high peak capacity is needed, a particulate column with small particles and small pores may be more useful. Choose also columns known to have long lifetime at operating mobile phase pH. Choose bonded phases based on high purity, low acidity silica for best peak shape. If the sample is consisting of polar and hydrophilic analytes an orthogonal selectivity to reversed phase should be selected. If chiral resolution is defined in the method goal, a suitable chiral column should be chosen etc. Use analyte specific structure information (chemical structure, log *P* values etc) to choose a proper stationary phase. If acidic or basic analytes are present in the sample; reversed phase ion suppression (for weak acids or bases), reversed phase ion-pairing (for strong acids or bases) or HILIC should be used. For low/medium polarity analytes, normal phase HPLC or HILIC are viable techniques, while HILIC, and particularly ZIC®-HILIC is the most suitable separation technique for polar and hydrophilic compounds.

Polarity scale of analyte functional groups

Polarity	Functional group	Hybridization	Intermolecular forces
Low	Methylene	s	London
	Phenyl	s / p	London
	Halide	s	London, Dipole-Dipole
	Ether	s	London, Dipole-Dipole, H-bonding
	Nitro	s / p	London, Dipole-Dipole, H-bonding
	Ester	s / p	London, Dipole-Dipole, H-bonding
	Aldehyde	s / p	London, Dipole-Dipole, H-bonding
	Ketone	s / p	London, Dipole-Dipole, H-bonding
	Amino	s / p	London, Dipole-Dipole, H-bonding, Acid-base chemistry
	Hydroxyl	s	London, Dipole-Dipole, H-bonding
High	Carboxylic acid	s / p	London, Dipole-Dipole, H-bonding, Acid-base chemistry

Choosing the right column format

Use the column selection guide to find the best column configuration for minimum analysis time with high efficiency and resolution, and match up method goals to make sure that the chosen format has the ability to produce resolution that fits the purpose of the application, e.g. choose right column length, column inner diameter, particle size and pore size. If you have sufficient resolution, it is also possible to speed up the separation by increasing the flow rate or shorten the column length. Silica-based materials are physically strong and will not shrink or swell, being compatible with a broad range of polar and non-polar solvents, and therefore often the initial choice. Most silica based columns are stable from pH 2–7.5, and historically, polymeric packing materials provided better column stability under pH extremes. A polymer-based packing material, like ZIC®-pHILIC, is compressible and may shrink or swell with certain solvents. Therefore care must be taken if a polymeric column is used, and the upper back-pressure limit is lower than corresponding silica based stationary phases. Newer high-purity silica based phases, like Purospher® STAR, are stable at pH 1.5–10.5, with the surface functional groups bound to the base silica particle at multiple attachment points via polymeric modification.

Particle size

Smaller particle sizes provide higher separation efficiency and higher chromatographic resolution than larger particle sizes. However, larger particle sizes offer faster flow rates at lower column back-pressure, and are less prone to clogging, and for these reasons are more tolerant to matrix effects. Typical particle sizes range from 3–20 μm , but new 2 μm particle sizes are available to maximize resolution on short Purospher® STAR columns. A 5 μm particle size represents the best compromise between efficiency and back-pressure for most non-high throughput applications.

Pore size

Choose a pore large enough to completely enclose your target molecule. If your molecule is larger than the pore, size exclusion effects will be seen and it will be difficult or impossible to retain. In general, packing materials with a smaller pore size have higher surface areas and higher capacities than packing materials with larger pore sizes. A larger surface area typically indicates a greater number of pores, and therefore a higher overall capacity. Smaller surface areas equilibrate faster, which is important for gradient elution analyses. Larger pores are better for interaction with large compounds, such as proteins.

Carbon load

For silica-based reversed-phase packing materials, carbon load indicates the amount of functional bonded phase attached to the base material. Phases with lower carbon loads are more weakly hydrophobic, which may significantly reduce retention times over phases with higher carbon loads. However, a higher carbon load will give higher capacity and often greater resolution, especially for compounds of similar hydrophobicity. Carbon load is not a relevant parameter for columns used in normal phase or HILIC mode.

Endcapping

Silica-based reversed-phase packing materials have free silanol groups that will interact with polar compounds. Endcapping the bonded phase minimizes these secondary interactions. Choose endcapped phases if you do not want interactions with polar compounds. Choose non-endcapped phases if you want enhanced polar selectivity, for stronger retention of polar organic compounds.

5 Mobile phase selection – solvents and buffers

In a previous chapter, insight has been given to mobile phase recommendations, solvent properties and buffer components. Herein, a summary of starting conditions are presented along with a discussion about the difference among isocratic and gradient elution. The mobile phase solvent strength is a measure of its ability to elute analytes of the column. It is generally controlled by the concentration of the solvent with the highest strength; for example, in reverse phase HPLC with aqueous mobile phases, the strong solvent would be the organic modifier; in normal phase and HILIC, it would be the most polar one. Worth pointing out is that cyano-bonded phases are easier to work with than plain silica for normal phase separations. The aim is to find the correct concentration of the strong solvent. With many samples, there will be a range of solvent strengths that can be used within the aforesaid capacity limits. Other factors (such as pH) may also affect the overall retention of analytes.

Isocratic elution

In partition chromatography, the mobile phase should be a moderate to weak solvent for the samples to achieve peak focusing and not to compromise the actual separation. A good rule of thumb is to achieve a capacity factor (retention factor, k) of 2 to 5 for an isocratic method. In both RP and HILIC mode, the preferred organic solvent is acetonitrile of two reasons; favorable UV transmittance and low viscosity. Methanol is a reasonable alternative, hence it may be worth changing the organic solvent if resolution is not achieved and adjust the percentage organic solvent in the mobile phase to accomplish maximum resolution and retention.

In reversed phase mode, the initial mobile phase pH should be selected with two considerations. Low pH that protonates column silanol groups and reduce their chromatographic activity is generally preferred, especially with non-encapped columns. Mobile phases having pH 1 to 3 with 20–50 mM buffer (Potassium Dihydrogen Phosphate, TFA or formic acid in water) is advisable depending on detection mode, and to increase temperature to reduce analysis time. Mobile phase solvents should be water miscible, have low viscosity, low UV cut-off, being non-reactive, and for these reasons acetonitrile, methanol and tetrahydrofuran (THF) are used with RP columns. Not all RP methods are suitable under acidic conditions, and other pH intervals may provide different selectivity. At mid pH, dipotassium hydrogen phosphate or ammonium acetate (not a true buffer, but rather a pH adjustable salt) are viable alternatives depending on detection mode. At high pH, dipotassium hydrogen phosphate and ammonium carbonate can be used as buffers to maintain pH above 8. Keep in mind that working at high pH, only columns with wider pH tolerability should be used, and for this purpose Purospher® STAR is an excellent choice.

Gradient elution

Often it is not possible to elute all analytes with a single mobile phase (isocratic) in the desired k' (2–5) range. It is therefore advisable to use gradient elution where the mobile phase strength, and sometime also pH and ionic strength, changes over time. Effectively this means that early in the gradient the mobile phase elution strength is low, and where the elution strength is increasing with time according to a defined program that maximises the number of peaks that can be resolved with a given resolution. This results in of the constant peak width observed in gradient elution, compared to isocratic elution where the peak width increases in proportion to retention time. Gradient elution is used to solve the general elution problem for samples containing mixtures of analytes with a wide range of polarities. Gradient elution will also give greater sensitivity, particularly for analytes with longer retention times, because of the more constant peak width (for a given peak area, peak height is inversely proportional to peak width). Common practice in method development is to run a broad gradient first to decide whether to use isocratic or gradient elution.

If $\Delta t/t_G \geq 0.25$ use **gradient elution** If $\Delta t/t_G \leq 0.25$ use **isocratic elution**

Where Δt is difference in the retention time between the first peak and last peak in the chromatogram, t_G is the gradient time; the time over which the solvent composition is changed. For most samples (unless they are extremely complex), short columns (10–15 cm) are recommended to reduce method development time. Such columns afford shorter retention and equilibration times. A flow rate of 1–1.5 mL/min should be used initially.

Gradient method development

Good laboratory practice is to not allow gradients going from 100% aqueous to 100% organic. For method ruggedness reasons (to get better mixing, to prevent precipitation of salt and to provide more robust gradient profiles) it is advisable to keep minimum 5% of each phase in both mobile phase bottles. In practice for a reversed phase method, this means mobile phase A contains 5% organic solvent and 95% aqueous, while mobile phase B contains 95% organic solvent and 5% aqueous.

It is advisable to initially run a wide scouting gradient (0 – 100% B) over 40–60 minutes. From this run decide whether isocratic or gradient elution is best for the application. If gradient mode is a more appropriate alternative, eliminate sections of the gradient and try to compress the analyte peaks in space as much as possible prior to the first and last eluting peak. To further improve the gradient profile and to shorten overall cycle times (including re-equilibration) try to reduce the gradient and total run time. Keep in mind that a segmented gradient can be an effective tool to improve the separation. Seldom is a linear gradient the best solution. If there is a need to improve the separation of two closely eluting peaks; change the solvent strength by varying the fraction of each solvent (gradient shape and steepness); change column temperature; change the mobile phase pH (in small units); use different mobile phase solvents and/or buffer components; and/or use a different selectivity by changing the stationary phase.

Method development & optimization

- 1 | Selection of the HPLC method and system
- 2 | Establish sample prep procedure
- 3 | Select detector
- 4 | Selection of initial conditions
- 5 | Perform preliminary separations
- 6 | Selectivity optimization**
- 7 | System optimization
- 8 | Method validation

6 Selectivity optimization

In HILIC mode, gradient elution is accomplished by increasing the polarity of the mobile phase, by decreasing the concentration of organic solvent, i.e. in the "opposite" direction compared to RPLC separations. With charged HILIC stationary phases, like ZIC®-HILIC there is also a possibility of increasing the salt or buffer concentration during a gradient to disrupt electrostatic interactions with the solute. After a gradient run the column has to be equilibrated with the starting concentration of the mobile phase before the next sample can be injected. It must be emphasized that HILIC stationary phases are less tolerant to fast gradients and short equilibrium times compared to RPLC phases. This is because the water in the aqueous layer within the stationary phase originates from the eluent and therefore is depending on its composition.

It is also worth mentioning that the column back-pressure will increase during the gradient. Failure to properly equilibrate columns will cause drifting retention times and poor reproducibility. In some cases, however, it is possible to reach a dynamic equilibrium with stable retention times if fast gradients are run repeatedly for a longer period of time, but this situation can be tricky to obtain and reproduce.

The direct disadvantages with gradient elution are the need of a more complex HPLC system, and the separation column requires re-equilibration after every analysis which makes injection-to-injection lengthier than for an isocratic method. It is not compatible with all detectors (i.e. RI and EC), more variables to control for reproducibility and system dwell volume (gradient delay volume) becomes important especially in scaling a separation or whenever transferring a method between instruments and/or laboratories. Therefore be aware that delay volumes will vary from instrument to instrument.

System optimization

7

To find the desired balance between resolution and analysis time after satisfactory selectivity has been achieved, parameters such as column dimension, particle size and flow rate should be optimized. With a truly scalable stationary phase, these parameters may be changed without affecting capacity factors or selectivity. With the introduction of smaller particle sizes and narrower column inner diameters, also optimization of the complete HPLC instrumentation is needed, and sometimes it is necessary to replace the whole system. An example of a successful complete system optimization is shown for Pantoprazole sodium (Pantoloc, Protium, Pantecta and Protonix; a proton pump inhibitor drug that inhibits gastric acid secretion).

The chemical structure of Pantoprazole sodium

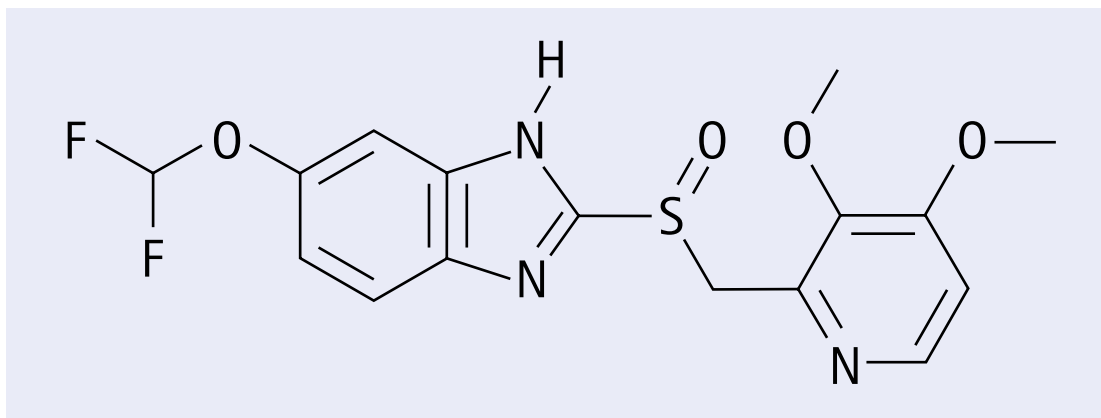

The original method was developed on a Purospher® STAR RP-18 endcapped 150 x 4.6 mm column with 5 µm particles with a total cycle time of 50 minutes. By changing to a Purospher® STAR RP-18 endcapped 50 x 2.1 mm column with 2 µm particles, lowering the flow-rate, and altering the gradient profile, it was possible to reduce the total analysis time from 50 to 5 minutes, maintaining sample peak profile (with improved resolution), at low back-pressure and high separation efficiency.

Method development & optimization

Chromatogram showing the purity profile of Pantoprazole sodium on a Purospher® STAR RP-18 endcapped 150 x 4.6 mm column with 5 µm particles

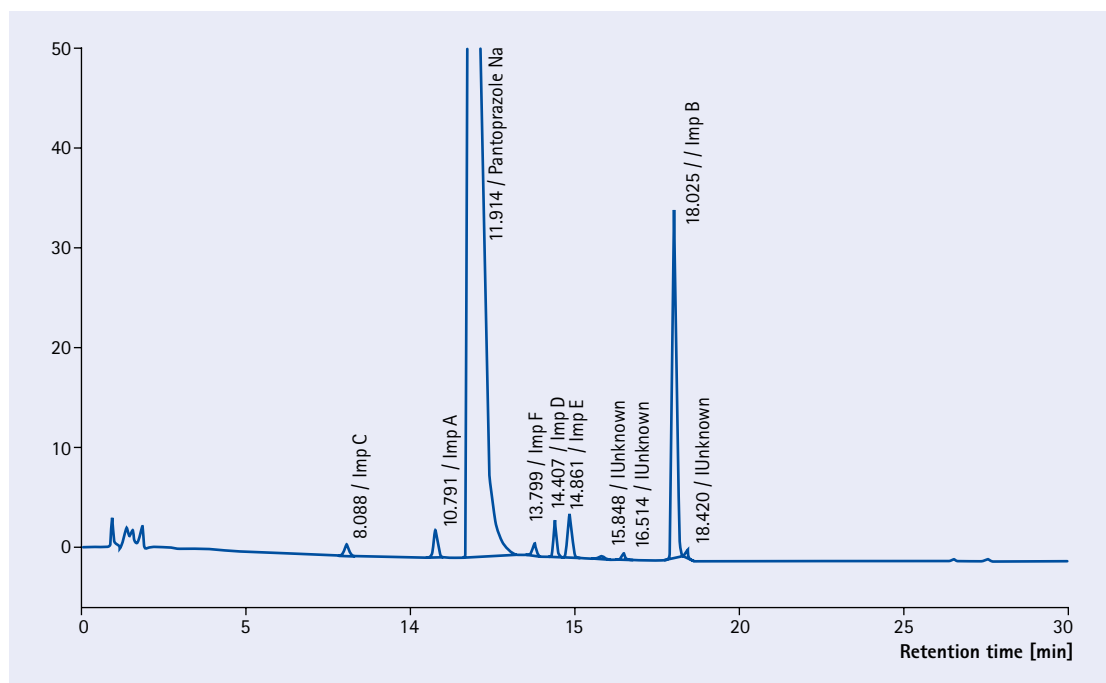

Column	Purospher® STAR RP-18 endcapped 150 x 4.6 mm, 5 µm
Mobile phase	A: 1.74 gram dipotassium hydrogen phosphate in 1000 mL water, adjusted pH to 7.0 with dilute phosphoric acid (330 gm/L) B: Acetonitrile
Gradient	initial composition 80% A and 20% B linear increase to 20% A and 80% B in 40 min followed by a 10 min re-equilibrium at initial composition
Flow rate	1 mL/min
Detection	UV 290 nm
Column temperature	40°C
Injection volume	20 µL
Sample	460 ppm in 1:1 mixture of ACN and 0.001 N NaOH

Chromatogram showing the purity profile of Pantoprazole sodium on a Purospher® STAR RP-18 endcapped 50 x 2.1 mm column with 2 µm particles

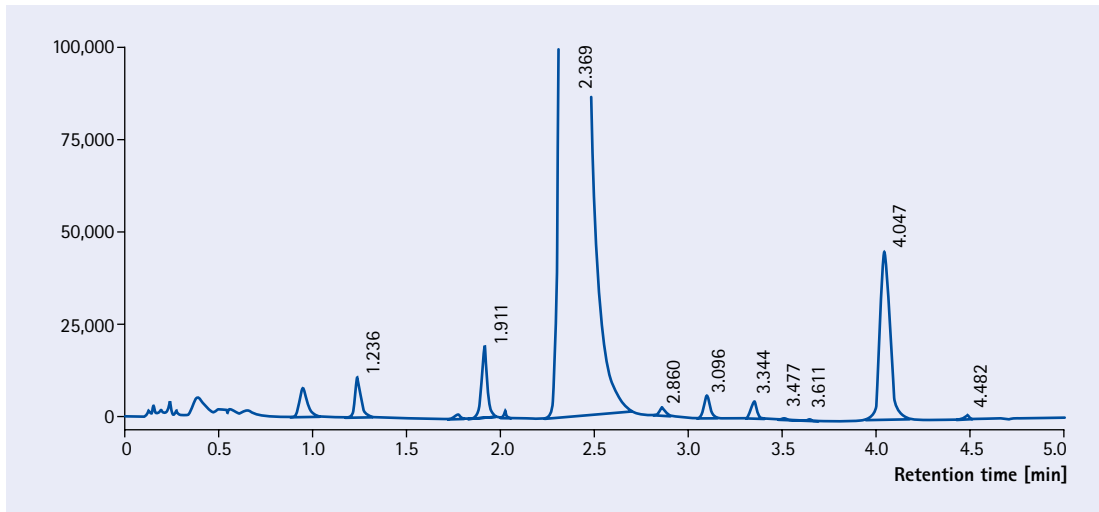

Column	Purospher® STAR RP-18 endcapped 50 x 2.1 mm, 2 µm
Mobile phase	A: 1.74 gram dipotassium hydrogen phosphate in 1000 mL water, adjusted pH to 7.0 with dilute phosphoric acid (330 gm/L) B: Acetonitrile
Gradient	initial composition 80% A and 20% B linear increase to 28% B in 1.5 min followed by an increase from 28 to 40% B between 1.5 and 4.0 min finally a re-equilibrium at initial composition for 1 min
Flow rate	0.6 mL/min
Detection	UV 290 nm
Column temperature	40°C
Injection volume	7 µL
Sample	460 ppm in 1:1 mixture of ACN and 0.001 N NaOH

8 Method validation

Proper validation of an analytical method is important to ensure that it will provide similar results, today-tomorrow-next week-next year, i.e. over a long period of time, in different laboratories independent of the analyst. Not only because of requirements from regulatory authorities, but rather to ensure good manufacturing practice (GMP) and good laboratory practice (GLP). It is especially important for pharmaceutical analysis when assurance of the continuing efficacy and safety of each batch manufactured relies solely on the determination of quality. Guidelines for the validation of analytical methods can be found at the International Council on Harmonization (ICH). The US Food and Drug Administration (FDA) and US Pharmacopeia (USP) both refer to ICH guidelines.

Keep in mind that analytical method validation should be isolated from the initial selection and development, which actually are only the first steps in establishing a routine analytical method. Validation means testing of the method to find out allowed variability for each method parameter. Routine quality control methods should guarantee that the analytical results of raw materials, excipients, intermediates, bulk products or finished products are viable.

In this section the most widely applied validation characteristics are explained; accuracy, precision (repeatability and reproducibility/intermediate precision), specificity, limit of detection, limit of quantitation, linearity, robustness and stability of analytical solutions.

Accuracy

An analytical method is accurate if it gives the right numerical value for the analyte (either mass or concentration) and can be described as the degree of closeness of measurements of a quantity to its actual value. A method almost never gives the exact same results for replicate analyses, which means that the result is presented as the mean or average. A pragmatic way to express accuracy is to present it in terms of the standard error, which is the difference between the observed and the expected concentrations of the analyte. To determine accuracy, a common practice is to analyze a known amount of standard material under different conditions in a formulation, bulk material or intermediate product to ensure that nothing interferes with the method.

Precision

Precision, this is also referred to as reproducibility or repeatability, defines how reproducible the acquired results are and gives you assurance in the attained data. Repeatability is the measure of how easy it is for an analyst in a given laboratory to attain the same result for the same batch of samples (normally by injecting the same samples repeatedly at different concentration levels) using the same method and using the same equipment and reagents. Reproducibility or intermediate precision measures the variations within or between days, analysts and equipment. High precision quantitative results should be expected, but depending if it is a pharmaceutical assay or a bio-analytical method, different acceptance criteria govern. In pharmaceutical quality control there are much more stringent method requirements and less variation amongst samples compared to analysis of patient plasma- or serum samples. For any assay, the relative standard deviation (RSD) or coefficient of variation (CV) is used as indication of the imprecision of the method. From a practical perspective, six to ten replicate injections will give you a good idea of the precision of the method. An analytical method can be accurate but not precise, precise but not accurate, neither, or both.

Specificity

Specificity is an important parameter to test in a validation program as it verifies the ability of the method to accurately measure the analyte response in the presence of all potential sample components. The analyte response from a solution containing only the analyte is compared with test samples containing the analyte and all potential sample components (placebo, synthesis intermediates, excipients, degradation products and impurities). For pharmaceuticals, stress conditions such as heat, light, acid, base and oxidant are typical. For formulated products, heat, light and humidity are commonly used to stress the samples. The analyte peak is evaluated in all test samples for peak purity and resolution from the nearest eluting peak.

Limits of detection and quantitation

The limit of detection (LOD) is defined as the least amount of an analyte in a sample that can be detected, and commonly expressed as the concentration level that is able to provide a signal-to-noise ratio of three ($S/N=3$). Limit of quantitation (LOQ) is defined as the lowest analyte concentration level that can be quantified with good precision and accuracy, and providing a signal-to-noise ratio of ten ($S/N=10$). LOD and LOQ can also be determined based on the standard deviation of the response and the slope of the calibration curve.

Linearity

The linearity of an analytical method is the capability to generate results that are directly proportional to the concentration of analyte in the sample. It is commonly illustrated as the interval between the upper and lower analyte concentration levels that may be determined with precision and accuracy. Linearity data is often calculated using the calibration curve correlation coefficient and the y-intercept. The relative standard deviation (RSD), intercept and slope of the calibration curve should also be calculated.

Robustness

The method robustness is a measure on how well an analytical method remains unaffected by small variations in the experimental conditions, but also how reliable the method is during normal use. Important parameters to monitor are changes in the mobile phase composition; mobile phase pH; changes in the gradient profile; changes in the buffer concentration; column temperature; and injection volume.

Analytical solution stability

Analytical solution stability can be divided into different sections; recovery; dilution; internal standard addition, etc. If an extraction process is used (either liquid-liquid or solid phase extraction) it must provide proper analyte recovery. A method with low analyte recovery and/or where the analyte is degraded during the sample preparation is not tolerable for routine quality control. Internal or external standards (reference substances) should be prepared in such way that they maintain their potency, and produce same response over time. Samples and standards should be tested for stability to verify stability over a normal analysis cycle. A rule of thumb is that the sample solutions, standard solutions and HPLC mobile phase should be stable for minimum 24 hours under defined storage conditions.

Further reading

www.merck-chemicals.com/chromatography

Column selection guide

This column selection guide will help to select the most suitable column for a specific application:

- 1 | Selection by chemical structure of the analyte
- 2 | Selection by stationary phase
- 3 | Selection by sorbent specifications
- 4 | Selection by column dimension
- 5 | Selection by USP classification

1

Selection by chemical structure of the analyte with the log *P* value*

The selection of a most appropriate stationary phase very much depends on the chemical structure of the compounds to be separated. One important parameter, that describes the chemical structure of a compound is the log *P* value*. This table shows the log *P* value* of representative compounds of important analyte groups.

Analyte group	Example	Structure	log <i>P</i> value*	
A	Aflatoxins	Aflatoxin G1	1.8	
	Alcohols	Ethyl alcohol	-0.1	
	Aldehydes	Benzaldehyde	1.5	
	Alkaloids	Quinine	2.9	
	Amino Acids	Aspartic acid	2	
	Antibiotics	Amoxicillin		-2
		Ranitidine		0.3
	Aromatic amines	Aniline	0.9	
	C	Carboxylic acids	Glucuronic acid	-2.3
Carotinoids		Canthaxanthin	11.4	
D	Dyes	Rhodamine	4.4	
E	Enantiomers	Thalidomide	0.3	
	Essential oils	Safrole	3	
	Esters	Atropine	1.8	

* log *P* value

The partition coefficient is a ratio of concentrations of un-ionized compound between the two solutions octanol and water. To measure the partition coefficient of ionizable solutes, the pH of the aqueous phase is adjusted such that the predominant form of the compound is un-ionized. The logarithm of the ratio of the concentrations of the un-ionized solute in the solvents is called log *P*. The log *P* value is also known as a measure of lipophilicity.

$$\log P_{\text{oct/wat}} = \log \left(\frac{[\text{solute}]_{\text{octanol}}}{[\text{solute}]_{\text{un-ionized water}}} \right)$$

Analyte group	Example	Structure	log Pvalue*
F	Fat soluble vitamins	Retinol	5.7
	Fatty acids	Stearidonic acid	5.9
	Flavonoids	Quercetin	1.5
G	Glycols	Ethylene glycol	-1.4
I	Inorganic ions	Chloride	0.8
K	Ketones	Cyclohexanone	0.8
N	Nitrosamines	N-Nitrosodimethylamine	-0,6
P	PAH	Anthracene	4.4
	PCB	Pentachlorobiphenyl	7.3
	Peptides	Neurokinin B	-1.6
	Pesticides	Glyphosate	-4.6
	Phenols	Bisphenol A	2.2
	Phospholipids	Phosphatidylserine	-3.5
S	Steroids	Progesterone	3.9
	Sugars	Lactose	-4.7
	Sugar Alcohols	Maltitol	-5.2
	Sulfonamides	Furosemide	2
	Sweeteners	Aspartame	-2.7
W	Water soluble vitamins	Folic Acid	-1.1

Please have a look on the next page to select the column which suits your application best.

2 Selection by stationary phase

If a compound is mainly of hydrophobic character with a positive log *P* value, then the use of a reversed phase column is advisable. Thus please select a C18 or C8 bonded phase for good retention and resolution. For low/medium polarity analytes, normal phase HPLC or HILIC are viable techniques, while HILIC, and particularly ZIC®-HILIC is the most suitable separation technique for polar and hydrophilic compounds. If a chiral resolution is the method goal, then a suitable chiral column should be chosen.

Stationary phase	USP code	Monolithic columns Type B	Page	Method			
<div style="display: flex; flex-direction: column; align-items: center; justify-content: center;"> <div style="writing-mode: vertical-rl; transform: rotate(180deg);">hydrophobic</div> <div style="writing-mode: vertical-rl; transform: rotate(180deg);">hydrophilic</div> </div>	RPLC	RP-18 endcapped	L1	Chromolith® RP-18e	172	LC/MS Fast HPLC	
					Chromolith® HR RP-18e	172	LC/MS
					Chromolith® CapRod® RP-18e	162	
		L1	RP-18				
		L1	RP-18 polar endcapped				
	NPLC	L7	RP-8 endcapped		Chromolith® RP-8e	188	LC/MS Fast HPLC
					Chromolith® CapRod® RP-8e	162	
	HILIC	L7	RP-8				
		L29					
		L10	CN				
		L20	Diol				
		L3	Si	Chromolith® Si	190	LC/MS Fast HPLC	
		L8	NH ₂	Chromolith® NH ₂	192		
			ZIC®	CapRod® ZIC®-HILIC	162	LC/MS	

e = endcapped | HR = HighResolution

Column selection guide

Selection by chemical structure of the analyte | 1

Selection by stationary phase | 2

Selection by sorbent specifications | 3

Selection by column dimension | 4

Selection by USP classification | 5

High purity silica particles Type B	Page	Method	Conventional silica particles Type A	Page	non silica based materials	Page	Method
Purospher® STAR RP-18e	219	LC/MS Fast HPLC	Superspher® RP-18e	248			
Purospher® RP-18e	240		LiChrospher® RP-18e	252			
Purospher® RP-18 HC	244		LiChrospher® RP-18	252			
			Superspher® RP-18	248			
			LiChrospher® PAH	258			
			LiChrospher® WP 300	256			
			LiChrosorb® RP-18	273			
Purospher® RP-18	242						
Purospher® STAR RP-8e	236	LC/MS Fast HPLC	LiChrospher® RP-8e	261			
			Superspher® RP-8e	248			
			LiChrospher® RP-8	261			
			LiChrospher® 60 RP-select B	264			
			Superspher® RP-8	248			
			LiChrosorb® RP-8	273			
			Aluspher® RP-select B	276			
			LiChrospher® 100 CN	268			
			Superspher® CN	248			
			LiChrospher® 100 DIOL	270			
			Superspher® DIOL	248			
Purospher® STAR Si	238	LC/MS	LiChrospher® Si 60 and Si 100	271			
			Superspher® Si	248			
Purospher® STAR NH ₂	238		LiChrospher® 100 NH ₂	269			
			Superspher® NH ₂	248			
ZIC®-HILIC	282	LC/MS			ZIC®-pHILIC	287	LC/MS

Column selection guide

3

Selection by sorbent specifications

A list of specification of column sorbents gives detailed information to all Merck Millipore analytical HPLC stationary phases.

Sorbent	USP Listing	Sorbent characteristic	Particle size	pH stability
hydrophobic [reversed-phase chromatography]				
Chromolith® RP-18 endcapped/ Chromolith® HighResolution RP-18e	L1	High-purity monolithic silica [Type B] with Octadecyl modification and endcapping	monolithic	2-7.5
Chromolith® RP-8 endcapped	L7	High-purity monolithic silica [Type B] with Octyl modification and endcapping	monolithic	2-7.5
LiChrospher®/Superspher® RP-18	L1	Conventional spherical silica particles [Type A] with Octadecyl modification	4, 5, 10 µm	2-7.5
LiChrospher®/Superspher® RP-18 endcapped	L1	Conventional spherical silica particles [Type A] with Octadecyl modification and endcapping	4, 5, 10 µm	2-7.5
LiChrospher®/Superspher® RP-8	L7	Conventional spherical silica particles [Type A] with Octyl modification	4, 5, 10 µm	2-7.5
LiChrospher®/Superspher® RP-8 endcapped	L7	Conventional spherical silica particles [Type A] with Octyl modification and endcapping	4, 5, 10 µm	2-7.5
LiChrospher®/Superspher® RP-select B	L7	Conventional spherical silica particles [Type A] with Octyl modification, base deactivated and endcapping	4, 5, 10 µm	2-7.5
Purospher® RP-18	L1	High-purity spherical silica particles [Type B] with Octadecyl modification and polar endcapping	5 µm	2-8
Purospher® RP-18 endcapped	L1	High-purity spherical silica particles [Type B] with Octadecyl modification and endcapping	5, 10 µm	2-8
Purospher® RP-18 HC	L1	High-purity spherical silica particles [Type B] with Octadecyl modification	5 µm	2-7.5
Purospher® STAR RP-18 endcapped	L1	High-purity spherical silica particles [Type B] with polymeric Octadecyl modification and endcapping	2, 3, 5 µm	1.5-10.5
Purospher® STAR RP-8 endcapped	L7	High-purity spherical silica particles [Type B] with Octyl modification and endcapping	3, 5 µm	1.5-10.5
hydrophilic [normal-phase chromatography and hydrophilic interaction chromatography HILIC]				
Chromolith® NH ₂	L8	High-purity monolithic silica [Type B] with amino bonding	monolithic	2-7.5
Chromolith® Si	L3	High-purity monolithic silica [Type B] unbonded	monolithic	2-7.5
LiChrospher®/Superspher® CN	L10	Conventional spherical silica particles [Type A] with Cyano bonding	5, 10 µm	2-7.5
LiChrospher®/Superspher® DIOL	L20	Conventional spherical silica particles (Type A) with Diol bonding	5, 10 µm	2-7.5
LiChrospher®/Superspher® NH ₂	L8	Conventional spherical silica particles [Type A] with amino bonding	5, 10 µm	2-7.5
LiChrospher®/Superspher® Si	L3	Conventional spherical silica particles [Type A] unbonded	4, 5, 10 µm	2-7.5
Purospher® STAR NH ₂	L8	High-purity spherical silica particles [Type B] with amino bonding	5 µm	2-7.5
Purospher® STAR Si	L3	High-purity spherical silica particles [Type B] unbonded	5 µm	2-7.5
SeQuant® ZIC®-HILIC	-	High-purity spherical silica particles [Type B] with patented zwitterionic bonding	3.5, 5 µm	2-8
SeQuant® ZIC®-pHILIC	-	Spherical polymeric particles with patented zwitterionic bonding	5 µm	2-12

Column selection guide

Selection by chemical structure of the analyte | 1

Selection by stationary phase | 2

Selection by sorbent specifications | 3

Selection by column dimension | 4

Selection by USP classification | 5

Matrix tolerability	MS suitability	Use in UHPLC instruments	Application
very high	high	high	Fast and robust separation of hydrophobic to medium polar compounds at low pressure
very high	high	high	Fast and robust separation of medium polar compounds at low pressure
medium – high	low – medium	low – medium	Medium to less polar compounds with ionizable functional groups
medium – high	low – medium	low – medium	Medium to less polar compounds with ionizable functional groups
medium – high	low – medium	low – medium	Separation of medium polar or position isomeric compounds
medium – high	low – medium	low – medium	Separation of medium polar or position isomeric compounds
medium – high	low – medium	low – medium	Separation of medium polar and basic compounds
medium	medium	medium	Very good for strong bases, polar endcapped (not suitable for separation of acids)
medium	high	medium	Separations of complex samples with simple eluents
medium	high	medium	Very good suitability for separation of polar, not basic compounds e.g. explosives.
low – medium	high	high	Allows the tailing-free separation of neutral, acidic, basic or chelating compounds. Excellent stability up to pH 10.5 enables the separation of strong basic compounds with alkaline eluents
medium	high	high	Separation of medium polar or position isomeric and basic compounds
very high	low – medium	medium-high	Fast and robust separation of carbohydrates
very high	high	high	Fast and robust separation of polar compounds with normal-phase or HILIC chromatography
medium – high	low – medium	low – medium	Provides polar and hydrophobic properties for normal-phase chromatography
medium – high	low – medium	low – medium	Provides polar and hydrophobic properties for normal-phase chromatography. Also suitable for size exclusion chromatography
medium – high	low – medium	low – medium	Separation of carbohydrates
medium – high	low – medium	low – medium	Separation of polar compounds with normal-phase or HILIC chromatography
medium	low – medium	low – medium	Separation of carbohydrates
medium	high	high	Separation of polar compounds with normal-phase or HILIC chromatography
medium-high	high	high	Excellent and robust separation of all types of polar and hydrophilic compounds in HILIC mode chromatography
medium-high	high	medium-high	For extra difficult separations of polar and hydrophilic compounds at extended pH range in HILIC mode chromatography

Column selection guide

- 1 | Selection by chemical structure of the analyte
- 2 | Selection by stationary phase
- 3 | Selection by sorbent specifications
- 4 | Selection by column dimension
- 5 | Selection by USP classification

4

Selection by column dimension

Depending on the scale of a separation and/or a needed separation efficiency of a separation, a column dimension specified by column inner diameter (i.d.) and column length has to be chosen.

Column dimension [length x i.d. in mm]	Application	Reason
4 x 4 10 x 10	Guard-column	Protection from mechanical contamination Sample contaminated to low extent
25 x 4	Precolumn	High capacity precolumn
30 x 2 / 2.1 / 3 / 4 55 x 2 / 2.1 / 3 / 4 75 x 4	Method development Rapid HPLC and UHPLC (if pressure stable)	Short retention time Rapid equilibration Low solvent consumption (small i.d.) Low pressure drop
100 x 2.1 125 x 2 / 3 150 x 2.1 / 3	High detection sensitivity (mass selectivity)	Semi-micro column for low injection volumes and low peak dispersion Low solvent consumption
100 x 4.6 125 x 4 / 4.6 150 x 4.6	Standard column	Adequate performance for most applications (average performance 8000 - 10000 N/column)
250 x 2 / 2.1 / 3	High detection sensitivity High performance separation	Semi-micro column for low injection volumes and low peak dispersion Low solvent consumption For complex samples
250 x 4 / 4.6	High performance separation	For very complex samples
250 x 10	Semi-preparative	For mg quantities of pure substance on lab scale
250 x 25	Preparative	For g quantities of pure substance

Guidelines for typical flow rates and orientation values for the loading capacities of analytical and semi-preparative columns

Column dimensions [length x i.d. in mm]	Typical flow rates	Sample amount	Sample volume
150 x 1	0.06 mL/min	≈ 0.05 mg	0.05 - 1 µL
250 x 2	0.25 mL/min	≈ 0.2 mg	0.2 - 5 µL
250 x 3	0.6 mL/min	≈ 1 mg	1 - 20 µL
250 x 4	1 mL/min	≈ 5 mg	5 - 80 µL
250 x 10	6 mL/min	≈ 30 mg	30 - 500 µL
250 x 25	39 mL/min	≈ 200 mg	200 - 3000 µL

5

Selection by USP classification

The following list describes the main USP classes and the corresponding Merck Millipore stationary phases. B is a base-compatible C-8 phase.

L1	Octadecylsilane, chemically linked to porous silica or ceramic micro particles with 5 or 10 µm in diameter	
	Product	Page
	Chromolith® HighResolution RP-18 endcapped	172
	Chromolith® RP-18 endcapped	172
	LiChrosorb® RP-18 (5 µm)	273
	LiChrosorb® RP-18 (7 µm)	273
	LiChrosorb® RP-18 (10 µm)	273
	LiChrospher® RP-18 (5 µm)	252
	LiChrospher® RP-18 (10 µm)	252
	Purospher® RP-18 (5 µm)	242
	Purospher® RP-18 endcapped (5 µm)	240
	Purospher® STAR RP-18 endcapped (3 µm)	219
	Purospher® STAR RP-18 endcapped (5 µm)	219
L3	Porous silica particles 5-10 µm diameter	
	Product	Page
	Chromolith® Si	190
	LiChrosorb® Si 60 (5 µm)	273
	LiChrosorb® Si 60 (10 µm)	273
	LiChrospher® Si 60 (5 µm)	271
	LiChrospher® Si 60 (10 µm)	271
	LiChrospher® Si 100	271
	Purospher® STAR Si (5 µm)	238
L7	Octylsilane, chemically bound to porous silica of 5 - 10 µm diameter	
	Product	Page
	Chromolith® RP-8 endcapped	188
	LiChrosorb® RP-8 (5 µm)	273
	LiChrosorb® RP-8 (7 µm)	273
	LiChrosorb® RP-8 (10 µm)	273
	LiChrosorb® RP-select B (5 µm)	273
	LiChrospher® RP-8 (5 µm)	261
	LiChrospher® RP-8 (10 µm)	261
	LiChrospher® RP-select B (5 µm)	264
	LiChrospher® RP-select B (10 µm)	264
	Purospher® STAR RP-8 endcapped (3 µm)	236
	Purospher® STAR RP-8 endcapped (5 µm)	236
	L8	Aminopropyl silane groups on porous silica of 5 - 10 µm diameter
Product		Page
Chromolith® NH ₂		192
LiChrospher® NH ₂ (10 µm)		269
Purospher® STAR NH ₂ (5 µm)		238
L10	Cyano groups bound to porous silica of 3 - 10 µm diameter	
	Product	Page
	LiChrosorb® CN (5 µm)	273
	LiChrospher® CN (5 µm)	268
	LiChrospher® CN (10 µm)	268
L20	Dihydroxypropane groups chemically bound to silica of 5 - 10 µm diameter	
	Product	Page
	LiChrosorb® DIOL (5 µm)	273
	LiChrospher® DIOL (5 µm)	270
	LiChrospher® DIOL (10 µm)	270
L29	Alumina-based polybutadiene spherical particles 5 µm	
	Product	Page
	Aluspher® RP-select B	276
L45	Beta cyclodextrin bonded to porous silica particles 5 to 10 µm in diameter	
	Product	Page
	ChiraDex® (5 µm)	290

Chromolith®

Speed and performance based on revolutionary monolithic silica technology

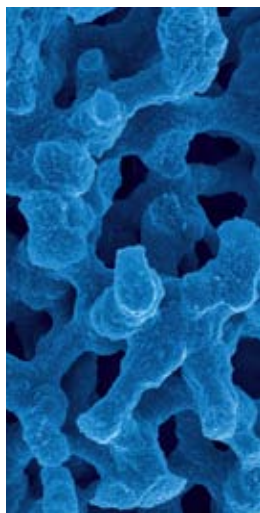

Chromolith® HPLC columns provide excellent separations in a fraction of the time that a standard particulate column will take, because they are made from highly porous monolithic rods of silica with a revolutionary bimodal pore structure. **The column is no longer packed with small particles but consists of a single piece of high-purity monolithic silica gel.** The Chromolith® HPLC columns are available as "ready-to-use columns" (no cartridge holder required).

Chromolith® HPLC columns are manufactured from the same metal-free silanes from which high purity particulate silica columns (eg. Purospher®) are made. This minimizes the time required to adapt an existing method from a particulate column to a Chromolith® column. **Longer Lifetime and Less Matrix-Sensitivity with biological samples** are advantages of Chromolith® columns reported by customers. Because of the rigid monolithic silica structure, column lifetime is substantially enhanced.

Speed of analysis and lower operating pressure are the most important benefits of Chromolith® columns. Compared with a 5µm particulate column, the speed of analysis can be typically 4-times faster. Alternatively, multiple columns can be coupled together to give high efficiencies at normal pressures! With Chromolith® HPLC columns, flow gradient methods are particularly attractive.



Chromolith® CapRod®

Monolithic capillary

Chromolith® CapRod® is a capillary column which combines the speed of monolithic silica technology with the sensitivity of nano-LC, hence enabling new productivity levels for high throughput, high sensitive proteomics-LC applications to be achieved. The unique combination of two different types of pores (large macropores to allow rapid transit of the eluent and small mesopores to create a large surface area) means that Chromolith® CapRod® provides excellent separations in a fraction of the time required by conventional particulate capillary columns. Compared to particulate capillary columns, Chromolith® CapRod® capillaries show a better performance as shown by optimal resolution (narrow peak widths), increased productivity like sample throughput and prolonged column life-time. Finally, column length is less limited, compared to any other type of column. The capillaries can even be bent to a certain degree in order to fit optimally in any LC configuration and instrument. Chromolith® CapRod® monolithic capillary columns are designed to work with various Nano or Capillary LC systems, providing highest efficiencies and performance when coupled to mass spectrometers, both on-line (ESI, nanospray) and off-line (MALDI).

In contrast to classical micro-particulate sorbents, Chromolith® CapRod® columns can be operated at comparatively high flow rates without loss of performance and other limitations due to column back-pressure. Flow rates can be dramatically increased without compromising resolution. Separations can be achieved at 1-3 µL/min compared to 200-400 nL/min for conventional media on a standard 100 µm LC capillary column. A trapping capillary is also being offered in order to protect the precious separation column and to optimize the separation efficiency when using complex biological samples.

Monolithic capillary columns have become increasingly important in the separation of biomolecules, especially in combination with mass spectrometry. As compared to particulate columns, monolithic capillaries do not require frits and have a much lower tendency to clog, thus allowing higher flow rates improving speed and quality of biomolecule characterization. The strong growing interest for µ- and nano- HPLC now will be excellently served with our offering of wide range monolithic silica capillaries differing in inner diameter (50 µm, 100 µm and 200 µm), bonded phase (C8, C18), pore structure (standard and high resolution) and length (5, 15 and 30 cm).

Specifications of Chromolith® CapRod®

Sorbent characteristics	Monolithic silica gel
Column inner diameter	0.05 (50 µm), 0.1 mm (100 µm) and 0.2 mm (200 µm)
Column length	150 mm, 300 mm
Surface modification	RP-8 endcapped, RP-18 endcapped
Macropore size	2 µm (1 µm for "HighResolution" products)
Mesopore size	13 nm
Surface area	300 m ² /g

- ▶ **Chromolith® RP-18 endcapped** Chromolith® RP-18 endcapped columns are the fastest C18 columns in the world. **page 172**
- ▶ **Chromolith® RP-8 endcapped** **page 188**
- ▶ **Chromolith® Si** **page 190**
- ▶ **Chromolith® guard cartridges and cartridge kit** **page 195**
- ▶ **Chromolith® column coupler** **page 198**
- ▶ **Chromolith® SemiPrep** Perfect scale-up from analytical to preparative LC **page 200**
- ▶ **Chromolith® Prep** Chromolith® – increase in speed, efficiency and productivity **page 204**

Recommended use and flow rate ranges

Recommended use	RP-18e 150 x 0.05	RP-8e 150 x 0.1	RP-18e 150 x 0.1 Trap	RP-18e 150 x 0.1	RP-18e 300 x 0.1	RP-18e 150 x 0.1 HR	RP-18e 50 x 0.2 Trap	RP-18e 150 x 0.2	RP-18e 150 x 0.2 HR
Separation of small molecules	•		•	•	•	•		•	•
Separation of peptides	•	•	•	•	•	•		•	•
Separation of proteins		•							
Micro ESI		•		•	•	•	•	•	•
Nano ESI	•	•		•	•	•	•		
High Resolution						•			•
Flow rates [µL/min]	0.2 – 0.8	0.4 – 3	1 – 10	0.4 – 3	0.2 – 1.5	0.1 – 0.4	10 – 50	5 – 20	0.5 – 2
Max. back-pressure [bar]	200	200	200	200	200	218	218	218	218

Ordering information – Chromolith® CapRod®

Product	Ordering No.	Dimension length	Dimension i.d.	Contents of one package
Chromolith® CapRod® RP-18e	1.50403.0001	150 mm	0.05 mm	1 Capillary, Sleeves, Fittings, Certificate of Analysis
Chromolith® CapRod® RP-8e	1.50400.0001	150 mm	0.1 mm	1 Capillary, Sleeves, Fittings, Certificate of Analysis
Chromolith® CapRod® RP-8e Trap	1.52031.0001 *	50 mm	0.1 mm	1 Capillary
Chromolith® CapRod® RP-18e Trap	1.50426.0001	50 mm	0.1 mm	1 Capillary
Chromolith® CapRod® RP-18e	1.50402.0001	150 mm	0.1 mm	1 Capillary, Sleeves, Fittings, Certificate of Analysis
Chromolith® CapRod® RP-18e	1.50424.0001	300 mm	0.1 mm	1 Capillary, Sleeves, Fittings, Certificate of Analysis
Chromolith® CapRod® RP-18e HighResolution	1.50404.0001	150 mm	0.1 mm	1 Capillary, Sleeves, Fittings, Certificate of Analysis
Chromolith® CapRod® RP-18e Trap	1.50409.0001	50 mm	0.2 mm	1 Capillary
Chromolith® CapRod® RP-18e	1.50405.0001	150 mm	0.2 mm	1 Capillary, Sleeves, Fittings, Certificate of Analysis
Chromolith® CapRod® RP-18e HighResolution	1.50407.0001	150 mm	0.2 mm	1 Capillary, Sleeves, Fittings, Certificate of Analysis
Chromolith® CapRod® ZIC®-HILIC	1.50415.0001 *	150 mm	0.1 mm	1 Capillary, Sleeves, Fittings, Certificate of Analysis

* Available from Oct.1st, 2012



CapRod® column

The outer diameter of the capillary is 360 nm.

Characterization of Chromolith® CapRod®

The new Chromolith® CapRod® capillary column is designed for the efficient and selective separation of peptides and protein digests and is especially suited for capillary or nano-LC. Based on proprietary sol-gel technology, highly porous monolithic rods of pure silica with a unique pore structure are formed. Each column has a macropore and a mesopore structure which gives it very high porosity. The macropores form a network of pores through which the eluent can rapidly flow, hence dramatically reducing separation time. The mesopores form the fine pore structure of the capillary interior and create a very large surface area onto which adsorption of the target molecule can occur. The Chromolith® CapRod® analytical capillary columns are supplied complete with sleeves and standard 1/16" PEEK fittings to allow for direct coupling to a UV detector or mass spectrometer.

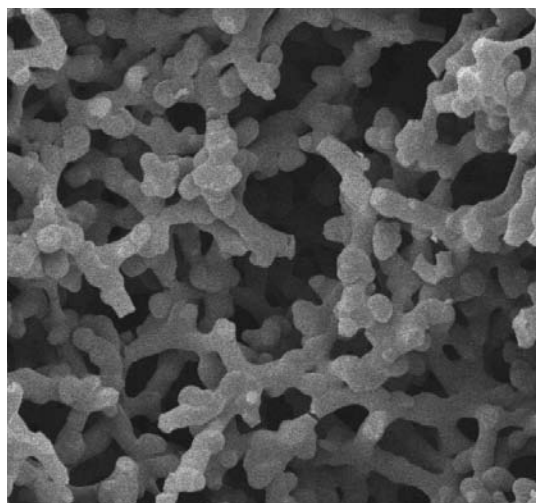

The cross section shows the bimodal pore structure of Chromolith® CapRod® with macropores at ~ 2 µm (1 µm for "HighResolution" products) and mesopores at 13 nm.

Separation examples on Chromolith® CapRod®

Column	Chromolith® CapRod® RP-8e 150 x 0.1 mm	
Mobile phase	A: 100% Water B: 100% Acetonitrile	
Gradient	3 min	12% B to 27% B
	1 min	hold
	11 min	27% B to 90% B
	5 min	hold
	followed with 25 min reequilibration	
Flow rate	2 µL/min	
Detection	Dionex Ultimate 3000 Variable Wavelength Detector; λ = 240 nm, cell volume 45 nL	
Temperature	25°C	
Injection volume	0.01 µL of the sample	
Pressure	16.6 MPa (2407 psi) 166 bar	
Sample	1. Fluoxymesterone	8.693 min
	2. Boldenone	9.313 min
	3. Methandrostenolone	9.887 min
	4. Testosterone	9.887 min
	5. Methyltestosterone	10.513 min
	6. Boldenone-Acetate	12.347 min
	7. Testosterone-Acetate	12.867 min
	8. Nandrolone-Propionate	13.240 min
	9. Testosterone-Propionate	13.607 min
	10. Nandrolone-Phenylpropionate	14.760 min
	11. Testosterone-Isocaproate	15.380 min

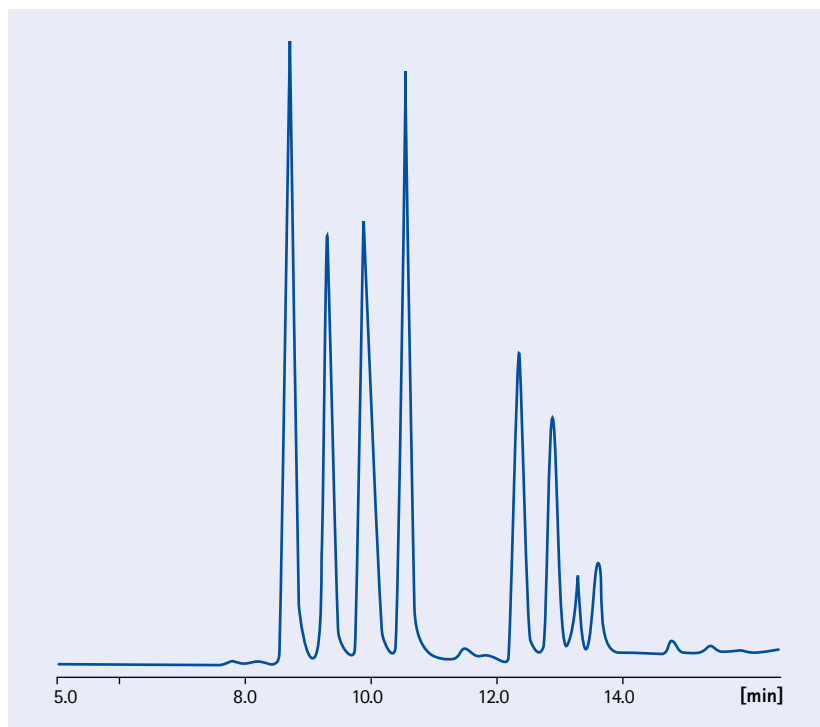

Separation examples on Chromolith® CapRod® Trypsin digested Cytochrom C

Column	Chromolith® CapRod® RP-18e (monolithic silica capillary column) 150 mm x 100 µm
Mobile phase	A: 0.1% formic acid in 2% acetonitrile B: 0.08% formic acid in 80% acetonitrile
Gradient	98% to 60% A in 35 minutes
Flow rate	2 µL/min
Injection volume	0.1 µL
Sample	Trypsin digested Cytochrom C (1mg/mL)

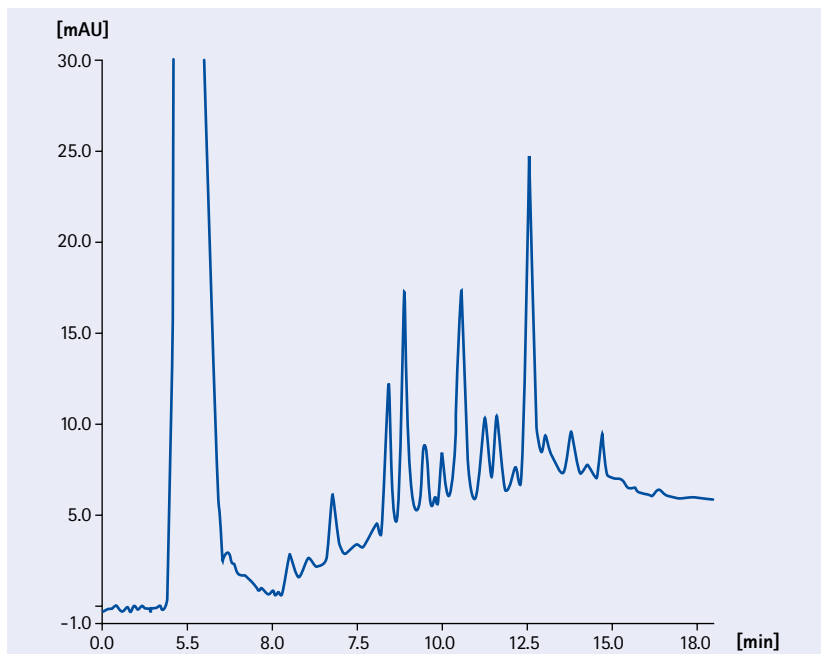

Column	Chromolith® CapRod® RP-18e HighResolution (monolithic silica capillary column) 150 mm x 100 µm
Mobile phase	A: 0.1% formic acid in 2% acetonitrile B: 0.08% formic acid in 80% acetonitrile
Gradient	98% to 60% A in 35 minutes
Flow rate	400 nL/min
Injection volume	0.1 µL
Sample	Trypsin digested Cytochrom C (1mg/mL)

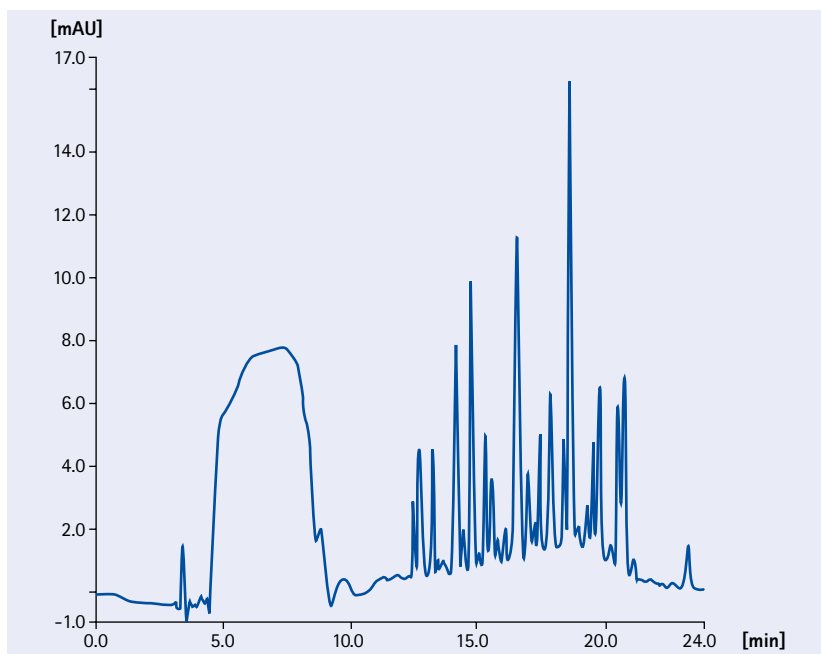

Separation examples on Chromolith® CapRod®

Small molecules

Column	CapRod® RP-18e 300 x 0.1 mm
Mobile phase	ACN/H ₂ O 70/30 v/v
Flow rate	0.4 mL/min Split 1/1000
Pressure	66 bar
Detection	210 nm
Temperature	ambient
Injection volume	6 µL
Sample	1. Uracil 2. Toluene 3. Ethylbenzene 4. Propylbenzene 5. Butylbenzene 6. Pentylbenzene 7. Hexylbenzene

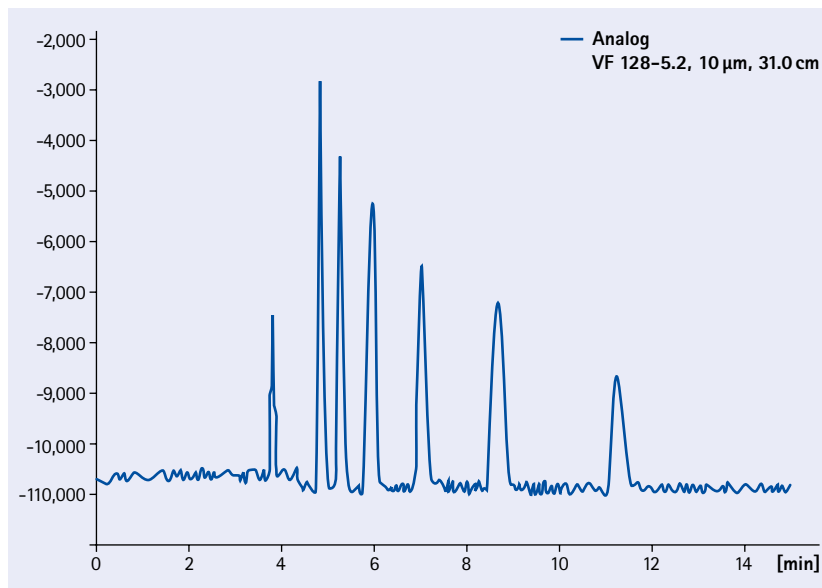

Separation repeatability for biological compounds

Excellent repeatability / reproducibility on monolithic silica capillaries. Long lifetime of capillary due to high mechanical stability of porous silica network.

Column	Chromolith® CapRod®, RP-18e 150 mm x 0.1 mm
Mobile phase	A: 2% ACN, 0.1% FA B: 80% ACN, 0.08% FA
Gradient	2% to 40% B in 35 min
Flow rate	3 µL/min
Sample	Cytochrom C digest

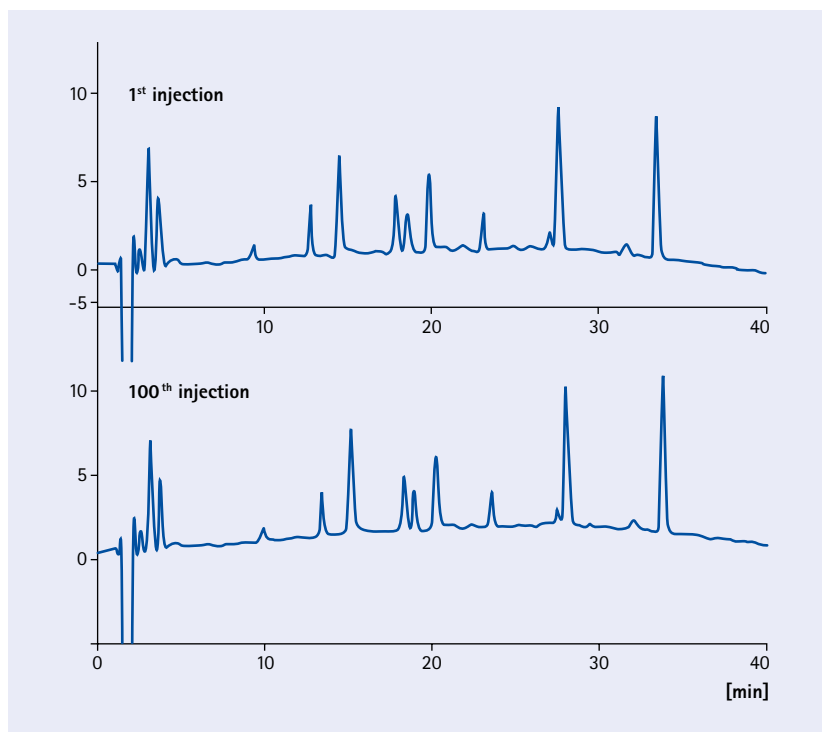

Chromolith® HPLC columns

Speed and performance in monolithic form

Chromolith® HPLC columns provide excellent separations in a fraction of the time that a standard particulate column will take, because they are made from highly porous monolithic rods of silica with a revolutionary bimodal pore structure. The column is no longer packed with small particles but consists of a single piece of high-purity polymeric silica gel.

This revolutionary bimodal pore structure provides a unique combination of macropores and mesopores.

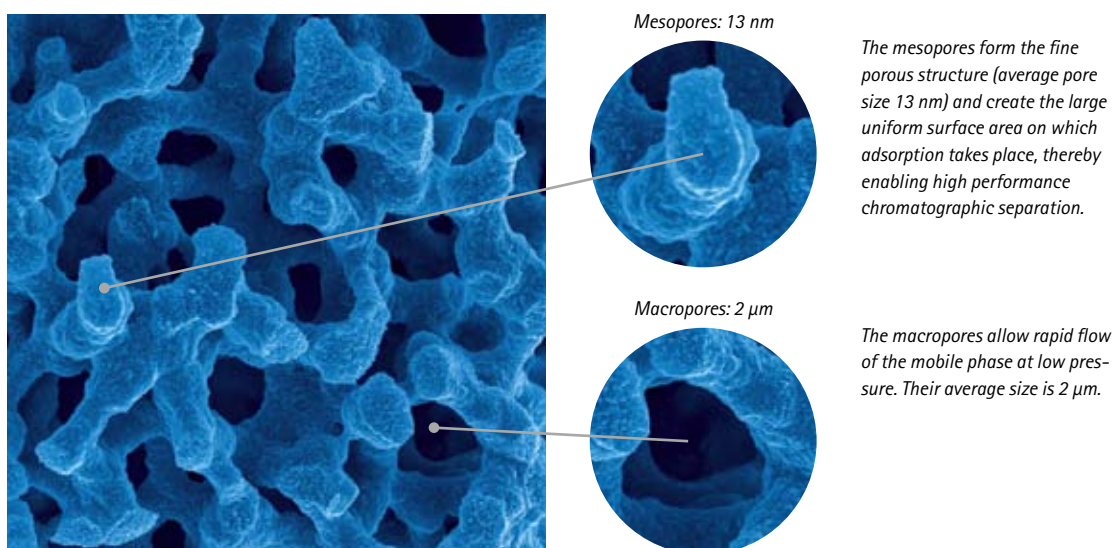

SEM picture of a cross section from a silica monolith.
Total porosity > 80%

Characterization of Chromolith® HPLC columns

The use of HPLC columns containing the classic 3 or 5 μm small silica particles often results in high back-pressure. This high back-pressure may damage both the column and the HPLC system; therefore, classic HPLC columns have limited length and a limited number of theoretical plates. Attempts have been made to increase the plate count by decreasing the particle size, but this results in unacceptable back-pressure and limits the variety of separations that can satisfactorily be achieved.

Particularly in industry, chromatographers are trying to find ways of balancing the need to analyze more samples with the limited financial and human resources available. Many of today's scientists wish to speed-up the entire separation process and therefore acceleration of the analysis processes has become one of the most important issues in the high performance liquid chromatography. Laboratory automation of HPLC systems has come a long way toward improving sample throughput by enabling 24 hours a day operation. The systems, however, are still limited by the separation technology itself, that is, the separation columns available. Chromolith® HPLC columns provide excellent separations in a fraction of the time that a standard particulate column will take, because they are made from highly porous monolithic rods of silica with a revolutionary bimodal pore structure. The column is no longer packed with small particles but consists of a single piece of high-purity polymeric silica gel.

Chromolith® columns at glance

Column internal diameter [mm]	Column length [mm]					Loadability	Sensitivity	Solvent saving
	Guard / Trap column 5 mm	Guard / Trap column 10 mm	25 mm	50 mm	100 mm			
25 mm		1.25260.0001*** 1.25261.0001*			1.25252.0001* 1.25251.0001***	+	-	-
	10 mm		1.52035.0001*** 1.52036.0001*		1.52016.0001* 1.52015.0001***			
4.6 mm	1.51470.0001* Kit	1.51471.0001* Kit	1.51463.0001*	1.51450.0001*	1.02129.0001*	-	+	+
	1.51451.0001* Pack of 3	1.51452.0001* Pack of 3	1.52020.0001* HR	1.52021.0001* HR	1.51468.0001**			
	1.52024.0001* HR Kit		1.52026.0001****	1.52027.0001****	1.51465.0001***			
	1.52025.0001* HR Pack of 3				1.52022.0001*			
	1.52029.0001**** Kit				HR			
	1.52030.0001**** Pack of 3				1.52028.0001****			
3 mm	1.52004.0001* Kit		1.52003.0001*	1.52002.0001*	1.52001.0001*	-	+	+
	1.52005.0001* Pack of 3							
2 mm	1.52008.0001* Kit		1.52014.0001*	1.52007.0001*	1.52006.0001*	-	+	+
	1.52009.0001* Pack of 3							
Speed						+		
Resolution						-		

* Chromolith® RP-18 endcapped | ** Chromolith® RP-8 endcapped | *** Chromolith® Si (silica) | **** Chromolith® NH₂ | HR = HighResolution

Benefits of Chromolith® HPLC columns at a glance

1. Speed of analysis

- Separations two times faster at half the column back-pressure compared to 5 µm columns
- Higher sample throughput – separations up to 9 times faster if required
- Fast column re-equilibration between analyses

2. Improved HPLC system security

- Significantly increased column lifetime
- Reduced maintenance on HPLC pump and injector seals
- Reduced need for sample preparation as columns very resistant to blocking (even with biological samples)

3. Column length no longer pressure limited

- Very high separation efficiency by column coupling

4. Standard HPLC instruments are ideally suited for use with Chromolith® HPLC columns

- Chromolith® columns clad in PEEK are very easy-to-use and handle

5. Cost savings from increased sample throughput can justify the expense of a method revalidation within one month.

Chromolith® HPLC columns

Speed of analysis

Macropores reduce the column back-pressure and allow the use of faster flow rates, thereby considerably reducing the analysis time. **Mesopores** form the fine porous structure and provide the very large active surface area for high efficiency separations.

With Chromolith® columns flow rates can now easily be varied from 1 mL up to 9 mL per minute with the same high quality resolution. A mixture of five beta-blocker drugs demonstrates the extreme time savings and high separation efficiency made possible with Chromolith® columns. Due to excellent mass transfer properties of the monolithic skeleton, high-speed separation is possible even at high flow rate. The beta-blockers were well separated with excellent peak symmetry. At 9 mL/min, the analysis time is less than 1 minute and the column back-pressure is only 153 bar.

Column	Chromolith® Performance RP-18 endcapped, 100–4.6 mm	
Mobile phase	Isocratic acetonitrile / 0.1% trifluoroacetic acid in water, 20/80 (v/v)	
Pressure	Total pressure (including HPLC system) 25°C	
Detection	UV 220 nm	
Injection volume	5 µL	
Sample	Atenolol	63 µg/mL
	Pindolol	29 µg/mL
	Metoprolol	108 µg/mL
	Celiprolol	104 µg/mL
	Bisoprolol	208 µg/mL

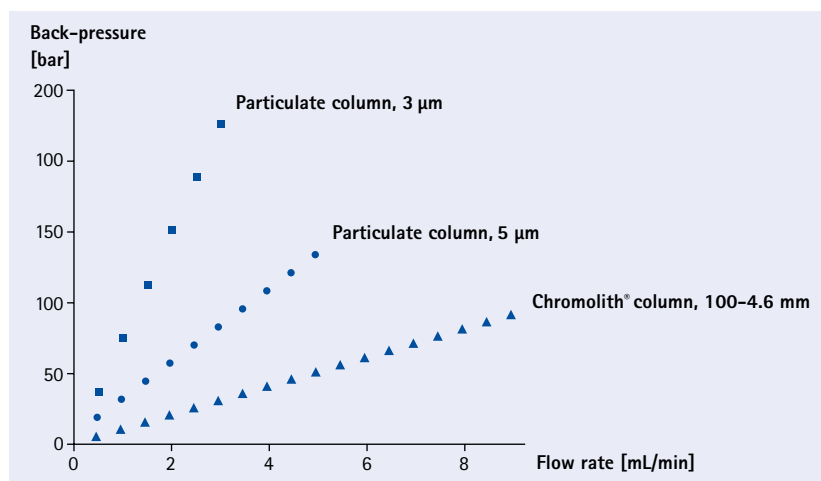

Column back-pressure at different flow rates. Comparison of a Chromolith® Performance column, 100–4.6 mm vs. equivalent classical particulate HPLC columns

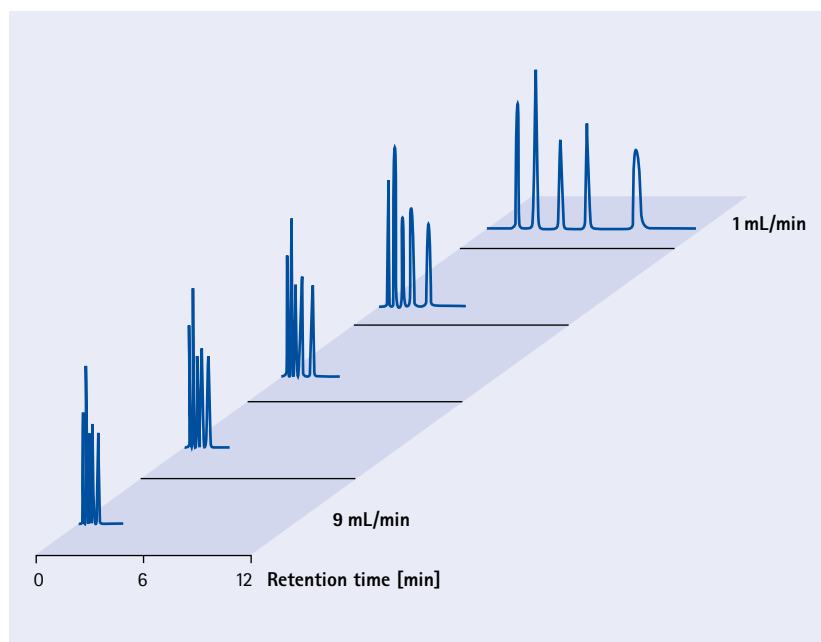

Flow programming

Chromolith® columns are very responsive to changes in flow rate. Flow rates can be changed in mid flow to either enhance the peak definition of the target compound or to shorten the total separation time once the target compound has successfully eluted. This is of particular value to more clearly separate two closely eluting peaks without affecting significantly the total run time. Likewise, it can also reduce total run time when certain compounds elute much later than all the other components of the sample.

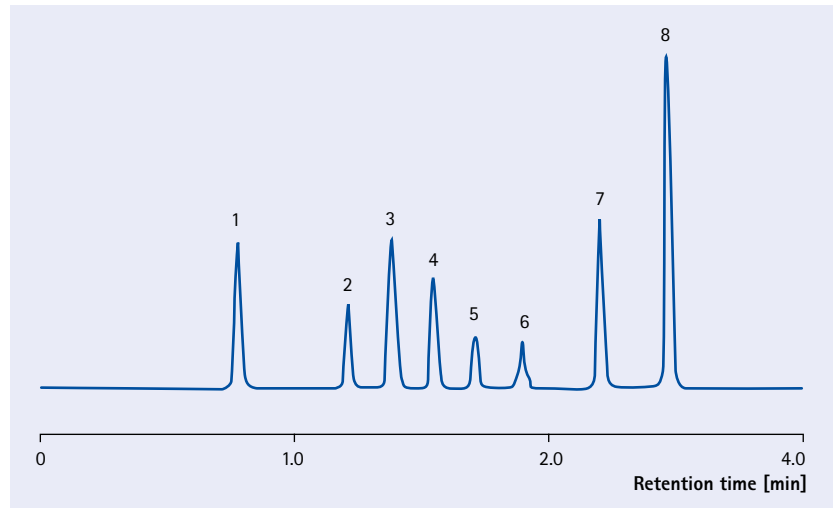

Column	Chromolith® Performance RP-18 endcapped, 100-4.6 mm			
Mobile phase	A: Acetonitrile B: 0.1% Phosphoric acid in water			
Double gradient	Time	%A	%B	Flow rate
	0 min	35	65	3 mL/min
	1.8 min	46	54	3 mL/min
	2.2 min	80	20	5 mL/min
	3 min	80	20	5 mL/min
Pressure	90 bar maximum total pressure			
Detection	UV 254 nm			
Temperature	22°C			
Injection volume	10 µL			
Sample	1. Phenol 2. 2-Chlorophenol 3. 2-Nitrophenol 4. 2,4-Dinitrophenol 5. Chloro-3-methylphenol 6. 2,4-Dinitro-6-methylphenol 7. 2,4,6-Trichlorophenol 8. Pentachlorophenol			



Chromolith® HPLC columns

High separation efficiency

Even the traditional plate count method of measuring quality shows that Chromolith® is better than a standard 5 µm particulate column and as good as a 3.5 µm, but with the ability to continue up to 9 mL/min without reaching HPLC system pressure limits. The van Deemter plot of the Chromolith® column demonstrates clearly that separation efficiency does not decrease significantly when the flow rate is increased, as is the case with particulate columns. It is therefore possible to operate monolithic columns at high flow rates with minimal loss of peak resolution.

For complex separations it is still necessary to use long columns in order to provide the separation efficiency required for resolution of all compounds of interest. Chromolith® HPLC columns can be connected in series to produce a column with high plate count at low back-pressure. (Please see Chromolith® column coupler). With particulate columns further column length is prevented by excessive back-pressure.

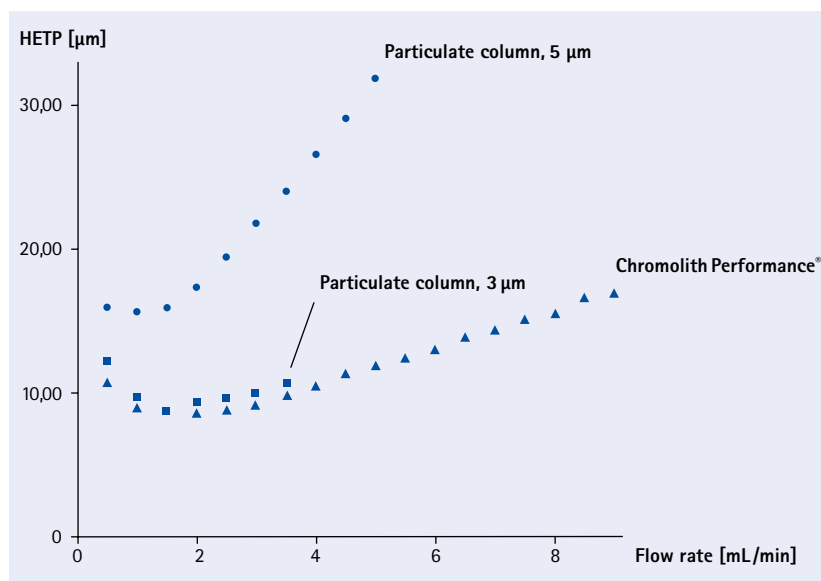

A van Deemter plot of the height equivalent to a theoretical plate (HETP) vs. flow rate for a Chromolith® Performance column and equivalent classical particulate HPLC columns.

Robustness, reliability and versatility

Long column lifetime and high resistance to column blockage reduce costs per analysis and enhance data integrity. Chromolith® HPLC columns have demonstrated immense robustness and set a new standard for long column lifetime. The rigid monolithic silica skeleton with 2 µm macropores is the reason for this improved performance. The following diagram shows the results of a stability test with 3,000 injections and 50,000 column volumes of mobile phase.

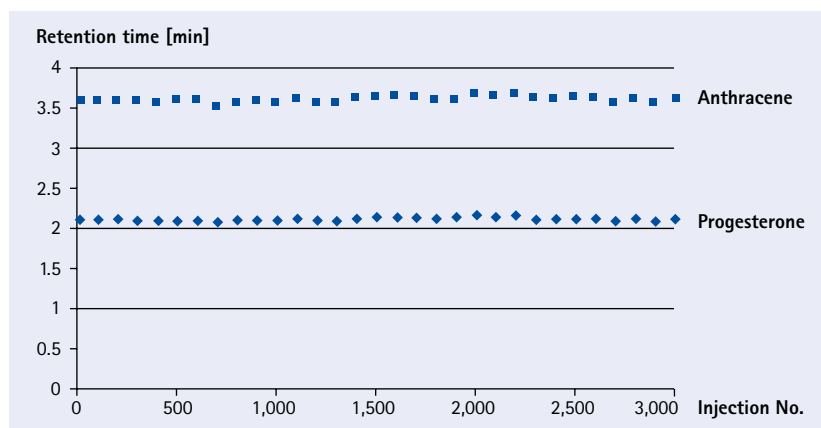

Cost savings

Using Chromolith® the time of analysis is much shorter than when using a particulate column. The cost per analysis can usually be halved at least, thereby paying back method revalidation expenses in about 3 weeks.

1 hour HPLC lab time in USA typically	costs	\$ 100	per hour
Revalidating one HPLC method requires 3 weeks lab time and	costs	\$ 12,000	per revalidation
New faster Chromolith® HPLC method cuts analysis time by 50% saving 4 hours per day	saves	\$ 400	per day
Run the new faster Chromolith® method for 30 days	total savings	\$ 12,000	after 30 days, revalidation has paid for itself
After running the new faster Chromolith® method for one year	total savings	\$ 80,000	assuming only 200 days

Optimal flow rate ranges for Chromolith® columns

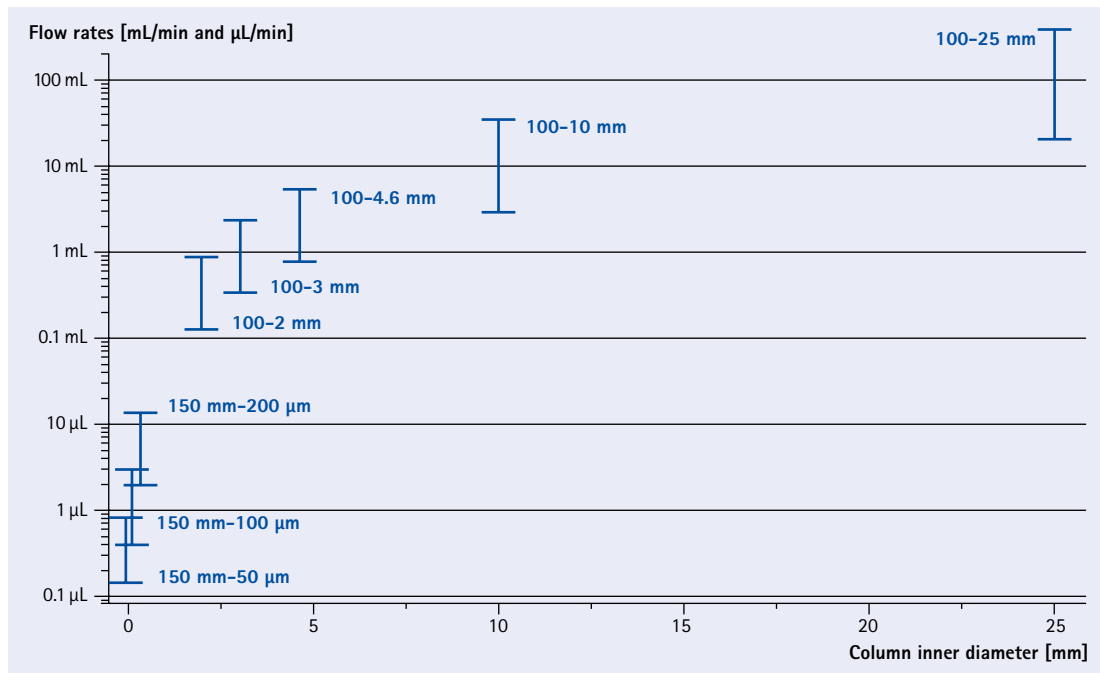

Chromolith® column length 100 mm for 2 mm, 3 mm, 4.6 mm, 10 mm and 25 mm column inner diameter

Chromolith® CapRod® column length 150 mm for 50 µm, 100 µm and 200 µm monolithic capillaries

Chromolith® RP-18 endcapped

Chromolith® RP-18 endcapped columns
are the fastest C18 columns in the world.

Chromolith® RP-18 endcapped

As the chemical basis of the Chromolith® RP-18 endcapped columns from the starting materials up to the surface modification procedures is the same as with the high-end conventional packed columns they possess a selectivity comparable to high-quality C18 endcapped packed reversed-phase columns. Therefore the chromatographer can use the standard methods when developing a new protocol. Chromolith® columns for reversed phase chromatography are based on a high-purity silica, the gold standard in HPLC, to reduce the negative effect of trace metals. They are chemically modified with n-alkyl chains with a high ligand density and then fully endcapped in order to reduce the effect of unmodified silanol groups.

Benefits of Chromolith® RP-18 endcapped

- high throughput at high flow rates with the best overall column quality
- the possibility of flow gradients
- added column performance by column coupling
- a rigid monolithic structure for a longer lifetime
- less matrix-sensitivity

Specifications of Chromolith® RP-18 endcapped

Silica type	High-purity
Particle size	Monolithic
Macropore size	1.5 µm (2 mm i.d. columns) 2 µm (25, 10, 4.6 and 3 mm i.d. columns)
Mesopore size	13 nm (130 Å)
Pore volume	1 mL/g
Total porosity	> 80%
Surface area	300 m ² /g
Surface modification	RP-18 endcapped
Carbon content	18%

Chromolith® HighResolution columns – the faster way for trouble-free high resolution separations

New Chromolith® HighResolution columns offering higher efficiency and improved peak shape at the expense of higher back-pressure which is anyway more than 2 times lower than any same dimension particulate packed column. At 1 mL/min flow rate a chromatogram run on a Chromolith® HighResolution column looks almost identical to the same chromatogram run on the particulate column packed with sub 3 µm particles. Chromolith® HighResolution is even able to generate similar results as column packed with 2.6 µm i.d. core-shell particles, however at much lower back-pressures.

Benefits of Chromolith® HighResolution columns

- Column performance corresponds to sub 3 µm particle packed columns and it is at least 50% higher compared to our standard Chromolith® columns
- Back-pressure still more than 2 times lower compared to particulate packed columns
- 30% longer column lifetime compared to particle packed columns

Specifications of Chromolith® HighResolution RP-18 endcapped

Silica type	High-purity
Particle size	Monolithic
Macropore size	1.15 µm
Mesopore size	15 nm (150 Å)
Pore volume	1 mL/g
Total pore volume	2.9 mL/g
Surface area	250 m ² /g
Surface modification	RP-18 endcapped
Carbon content	18%

▶ Chromolith® CapRod®
Monolithic capillary
page 161

▶ Chromolith® RP-8
endcapped
page 188

▶ Chromolith® Si
page 190

▶ Chromolith®
guard cartridges and
cartridge kit
page 195

▶ Chromolith® column
coupler
page 198

▶ Chromolith® SemiPrep
Perfect scale-up from
analytical to preparative
LC
page 200

▶ Chromolith® Prep
Chromolith® – increase
in speed, efficiency and
productivity
page 204

Differentiation between Chromolith® and Chromolith® HighResolution

New Chromolith® HighResolution has around 50% higher efficiency, excellent peak symmetry and still more than 30% longer lifetime compared with particulate columns. Two Chromolith® HighResolution columns could be easily coupled in order to achieve even higher resolution. The completely endcapped stationary phase enables the peak-tailing free elution of basic compounds. Samples rich of matrix should be analyzed with Chromolith® as this type of column will have longer lifetime. Also lower back-pressure would allow one to couple more columns once it is needed.

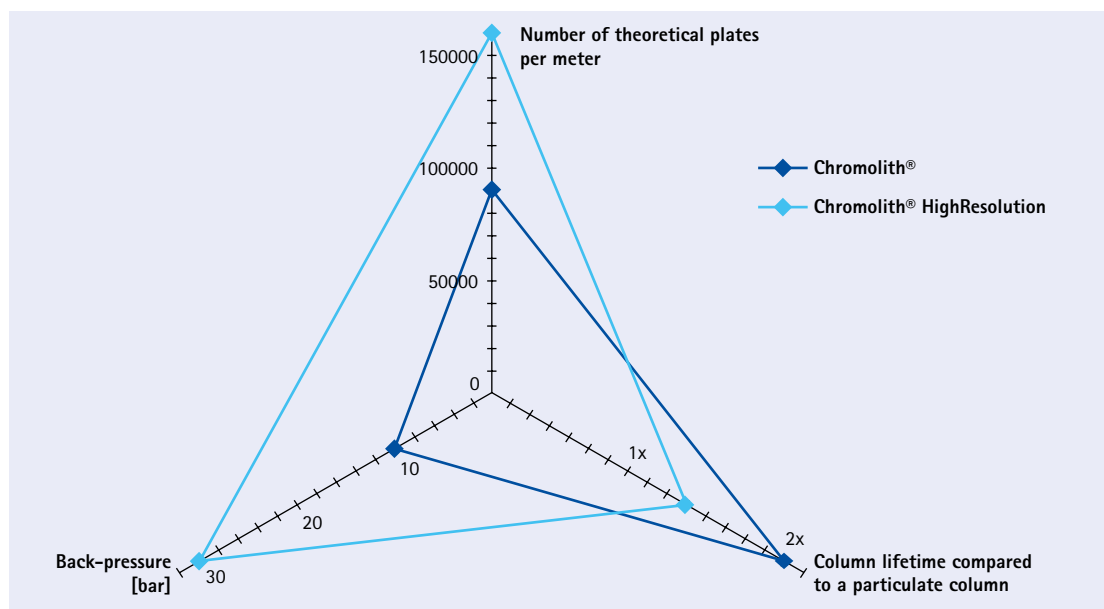

Higher efficiency, symmetrical peaks

**Chromolith® Performance RP-18e,
100-4.6 mm**

**Chromolith® HighResolution RP-18e,
100-4.6 mm**

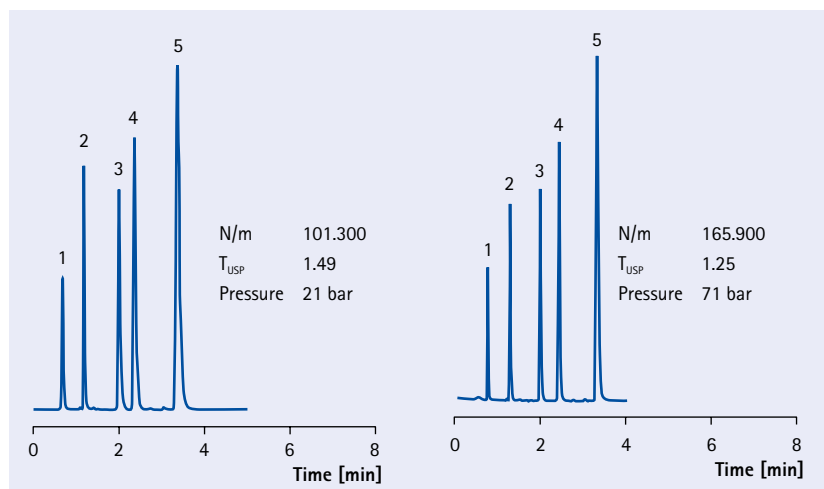

Mobile phase	Acetonitrile/ water 60/40
Flow rate	2 mL/min
Detection	UV 254 nm
Temp.	ambient
Injection volume	5 µL
Sample	1. Urea 2. Biphenyl-2-ol 3. Progesterone 4. Hexanophenon 5. Anthracene

Improved peak shape for basic compounds

Completely endcapped stationary phase enables the elution of basic compounds with no tailing.

Chromolith® HighResolution RP-18e, 100–4.6 mm

Mobile phase	A: ACN B: 20 mM NaH ₂ PO ₄ buffer pH 7.6
Gradient	0 min 20% A 0.5 min 45% A
Flow rate	2 mL/min
Column pressure	63–69 bar
Detection	UV 254 nm
Vol. detector cell	16 µL
Temperature	ambient
Injection volume	1 µL
Sample	1. Caffeine 2. Aniline 3. N-Methylaniline 4. 2-Ethylaniline 5. 4-Nitranisole 6. N,N-Dimethylaniline

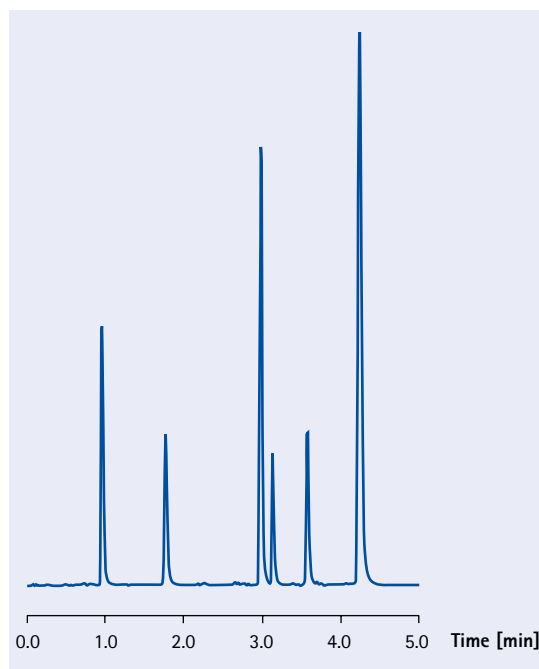

Excellent batch-to-batch reproducibility

The batch-to-batch reproducibility of Chromolith® HPLC columns is tightly controlled and fulfills the requirements for QA/QC laboratories.

Chromolith® HighResolution RP-18e, 100–4.6 mm

Mobile phase	A: Acetonitrile + 0.1% TFA B: Water + 0.1% TFA
Gradient	2 min 0% A 10 min 30% A
Flow rate	1 mL/min
Detection	UV 210 nm
Temp.	25°C
Injection volume	2 µL
Sample	1. Norepinephrine 2. Octopamine 3. Epinephrine tartrate 4. Dopamine 5. DOPA 6. Norephedrine 7. Ephedrine 8. N-Methylephedrine

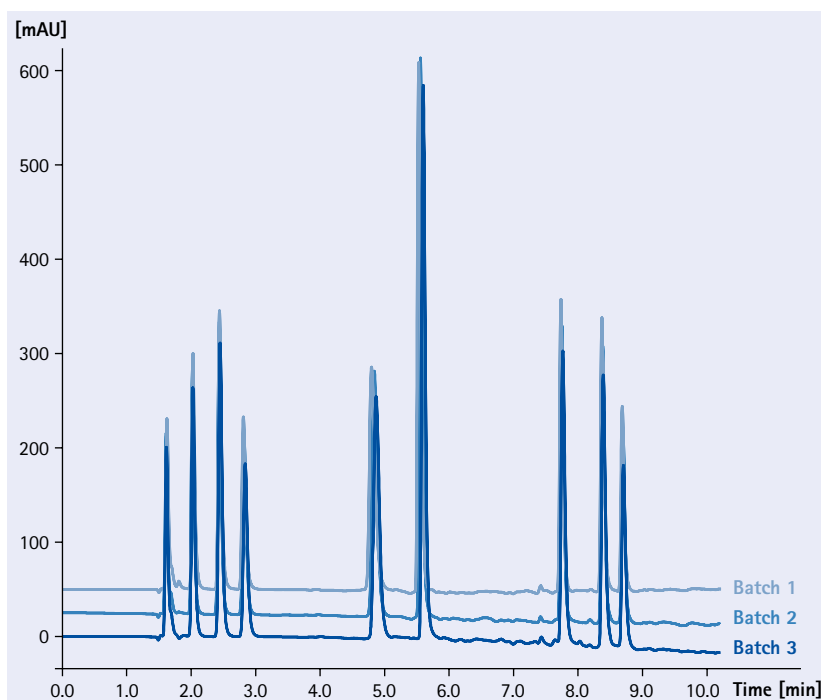

Ordering information – Chromolith® RP-18 endcapped

Product	Ordering No.	Dimension length	Dimension diameter	Contents of one package
Chromolith® Performance RP-18 endcapped	1.02129.0001	100 mm	4.6 mm	1 piece
Chromolith® SpeedRod RP-18 endcapped	1.51450.0001	50 mm	4.6 mm	1 piece
Chromolith® Flash RP-18 endcapped	1.51463.0001	25 mm	4.6 mm	1 piece
Chromolith® Performance RP-18 endcapped validation kit	1.51466.0001	100 mm	4.6 mm	3 pieces
Chromolith® Performance RP-18 endcapped	1.52001.0001	100 mm	3 mm	1 piece
Chromolith® FastGradient RP-18 endcapped	1.52002.0001	50 mm	3 mm	1 piece
Chromolith® Flash RP-18 endcapped	1.52003.0001	25 mm	3 mm	1 piece
Chromolith® Performance RP-18 endcapped	1.52006.0001	100 mm	2 mm	1 piece
Chromolith® FastGradient RP-18 endcapped	1.52007.0001	50 mm	2 mm	1 piece
Chromolith® Flash RP-18 endcapped	1.52014.0001	25 mm	2 mm	1 piece

Ordering information – Chromolith® HighResolution RP-18 endcapped

Product	Ordering No.	Dimension length	Dimension diameter	Contents of one package
Chromolith® HighResolution RP-18 endcapped	1.52022.0001	100 mm	4.6 mm	1 piece
Chromolith® HighResolution RP-18 endcapped	1.52021.0001	50 mm	4.6 mm	1 piece
Chromolith® HighResolution RP-18 endcapped	1.52020.0001	25 mm	4.6 mm </td <td>1 piece</td>	1 piece



Chromolith® RP-18 endcapped products

Three different column lengths of **Chromolith® RP-18 endcapped** are available: such as the **Chromolith® Flash RP-18e**, the **Chromolith® SpeedROD/FastGradient RP-18e** and the **Chromolith® Performance RP-18e** columns, which are opening the door to high-speed separations!

Chromolith® 25 mm length – for ultra-fast separation of simple mixtures



Chromolith® Flash RP-18 endcapped columns are very short and perfect for ultra-fast analysis simple mixtures. The length of the column is 25 mm and therefore the number of theoretical plates of the **Chromolith® Flash RP-18 endcapped column** is sufficient for easy separations. The major focus of the **Chromolith® Flash RP-18 endcapped columns** is clearly on the speed of analysis, since it provides the chromatographer with the fastest HPLC column, which is available on the market!

Chromolith® 50 mm length – for fast separation of simple mixtures



Chromolith® SpeedROD RP-18 endcapped columns are short and perfect for fast analysis. **Chromolith® SpeedROD RP-18 endcapped HPLC columns** are ideal for use in rapid screening of samples especially for the in-process control as well as in research laboratories or those specializing in organic synthesis, e.g. combinatorial chemistry.

Chromolith® 100 mm length – for rapid separation of more complex mixtures



Chromolith® Performance RP-18 endcapped columns provide rapid high quality separation of complex multi-component mixtures. They are therefore perfect for use as a routine analytical tool in the quality control laboratory or in research laboratories where more complex mixtures are being analyzed.

Chromolith® Performance RP-18 endcapped 100–4.6 mm validation kit

For correct method validation, it is essential to assess all possible sources of variations. To assist the validation process, the **Chromolith® validation kit** includes three columns from three different production batches, in order to compare the batch-to-batch reproducibility and quality. The **Chromolith® Performance RP-18 endcapped validation kit** is therefore perfect for use as an appropriate tool in quality control laboratories or in validation laboratories. The cost and time savings through use of Chromolith® columns can repay the expense of a method revalidation within one month.

Separation examples on Chromolith® RP-18 endcapped

Column	Chromolith® Performance RP-18 endcapped, 100-4.6 mm		
Mobile phase	A: Acetonitrile B: 20 mM Phosphate buffer pH 4.5		
Gradient	Time/min	% A	% B
	0.0	20	80
	3.0	60	40
Flow rate	4 mL/min		
Detection	230 nm		
Temperature	22°C		
Injection volume	10 µL		
Sample	1. Ascorbic acid	100 µg/mL	
	2. 4-Hydroxybenzoic acid	100 µg/mL	
	3. Benzoic acid	100 µg/mL	
	4. Sorbic acid	50 µg/mL	
	5. Methyl 4-hydroxybenzoate	100 µg/mL	
	6. Ethyl 4-hydroxybenzoate	150 µg/mL	
	7. Propyl 4-hydroxybenzoate	100 µg/mL	

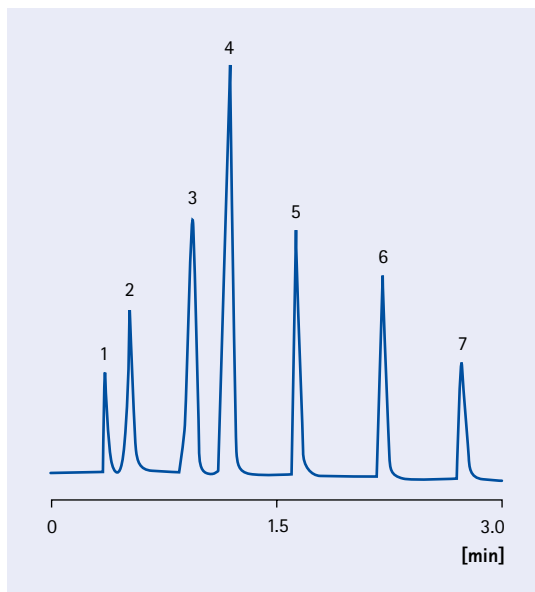

Chromolith® SpeedROD RP-18 endcapped

Column	Chromolith® SpeedROD RP-18 endcapped, 50-4.6 mm		
Mobile phase	A: Acetonitrile B: 0.01M Phosphate buffer pH 5.0		
Gradient	Time/min	% A	% B
	0.0	3	97
	2.5	3	97
	2.6	8	92
	5.0	8	92
Flow rate	4 mL/min		
Detection	227 nm		
Temperature	ambient		
Injection volume	10 µL		
Sample	1. Acesulfame-K	23 µg/mL	
	2. Saccharin	29 µg/mL	
	3. Benzoic acid	13 µg/mL	
	4. Sorbic acid	14 µg/mL	
	5. Caffeine	47 µg/mL	
	6. Aspartame	100 µg/mL	

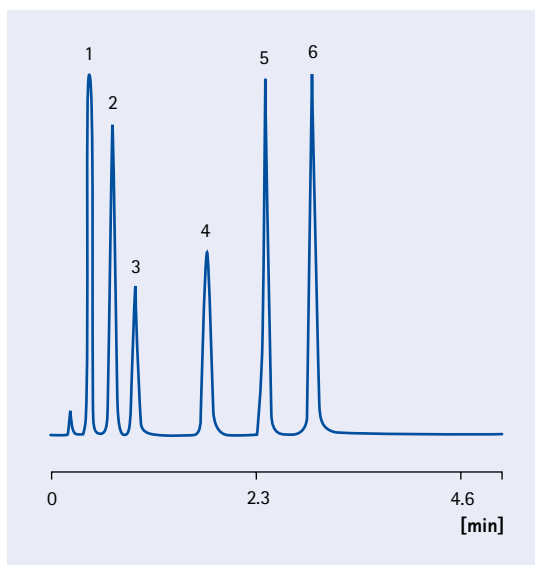

Chromolith® Performance RP-18 endcapped Separation of Carbidopa

Column	Chromolith® Performance RP-18 endcapped, 100-4.6 mm	
Mobile phase	A: Methanol B: 0.1% TFA in water	
Gradient	0.0 min 100% B 1.0 min 100% B 10 min 80% B	
Flow rate	2 mL/min	
Detection	UV 282 nm	
Temperature	ambient	
Injection volume	5 µL	
Sample	1. 2,4,5 Trihydroxyphenalalanine	125 µg/mL
	2. Levodopa	235 µg/mL
	3. Methylodopa	160 µg/mL
	4. Dopamine	190 µg/mL
	5. Carbidopa	175 µg/mL
	6. 3,4-Dihydroxyphenylacetic acid	185 µg/mL
	7. 3-o-Methylcarbidopa	105 µg/mL

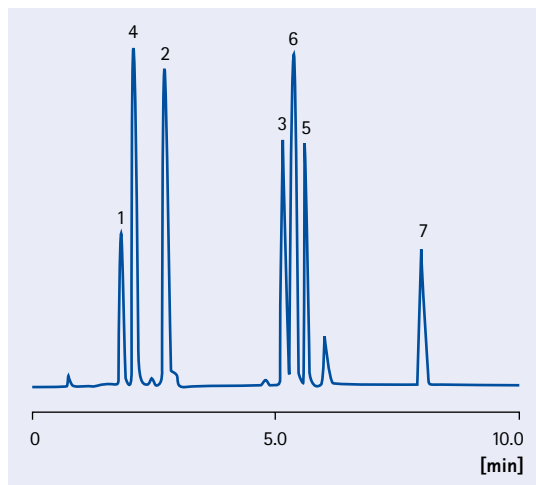

Developed by ChromSword Auto software

Separation of Steroids

Column	2 columns of Chromolith® Performance RP-18 endcapped	
Mobile phase	A: Acetonitrile B: Water	
Gradient	0 min 80% B 7.0 min 10% B	
Flow rate	3.0 mL/min	
Detection	UV 220 nm	
Temperature	ambient	
Injection volume	10 µL	
Sample	1. Prednisolone	
	2. Cortisone	
	3. Nortestosterone	
	4. Estradiol	
	5. Testosterone	
	6. Corticosterone	
	7. Estrone	
	8. Progesterone	

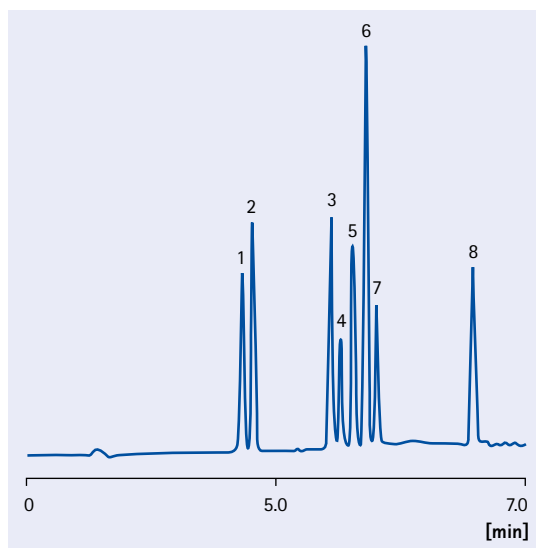

Chromolith® HighResolution is the ideal alternative to a sub 3 µm particulate column

At 1 mL/min flow rate a chromatogram run on a Chromolith® HighResolution column looks almost identical to the same chromatogram run on the corresponding particulate column. A Chromolith® HighResolution is able to generate similar results to a column packed with core-shell particles, however at much lower back-pressure.

Column	Chromolith® HighResolution RP-18, 50-4.6 mm, Silica monolith		
Mobile phase	A: Acetonitrile B: 20 mM Phosphate buffer pH 4.5		
Gradient	Time/min	% A	% B
	0.0	20	80
	12.0	40	60
Flow rate	1.0 mL/min		
Pressure	40 bar		
Detection	UV 230 nm		
Temperature	22°C		
Injection volume	2 µL		
Sample	1. Ascorbic acid 2. 4-Hydroxybenzoic acid 3. Benzoic acid 4. Sorbic acid 5. Methyl 4-hydroxybenzoate 6. Ethyl 4-hydroxybenzoate 7. Propyl 4-hydroxybenzoate		

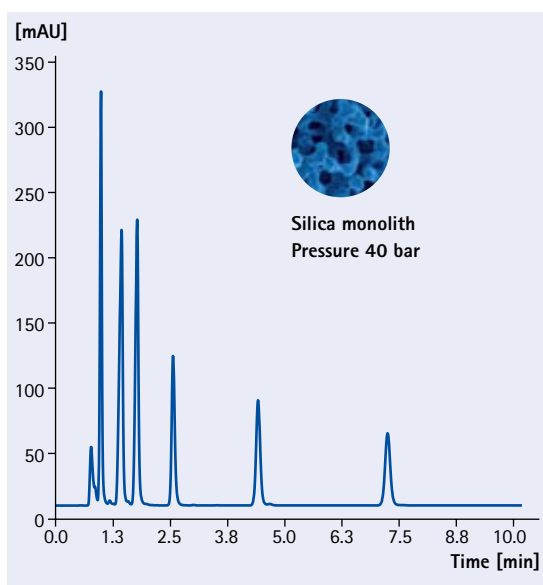

Column	Core-shell RP-18e, 50-4.6 mm, 2.6 µm particles		
Mobile phase	A: Acetonitrile B: 20 mM Phosphate buffer pH 4.5		
Gradient	Time/min	% A	% B
	0.0	20	80
	12.0	40	60
Flow rate	1.0 mL/min		
Pressure	100 bar		
Detection	UV 230 nm		
Temperature	22°C		
Injection volume	2 µL		
Sample	1. Ascorbic acid 2. 4-Hydroxybenzoic acid 3. Benzoic acid 4. Sorbic acid 5. Methyl 4-hydroxybenzoate 6. Ethyl 4-hydroxybenzoate 7. Propyl 4-hydroxybenzoate		

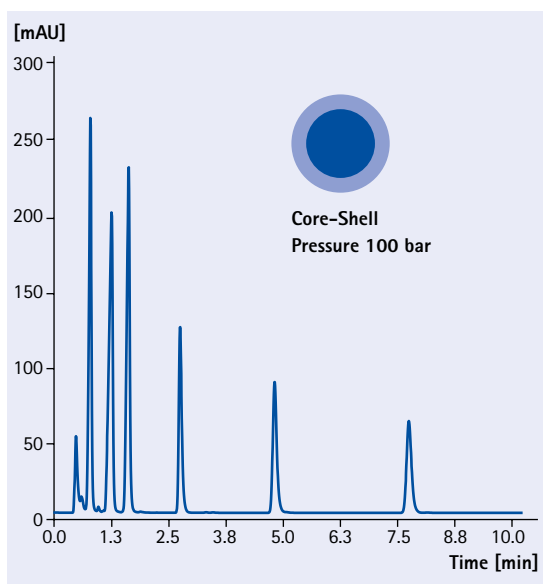

Speed is there when you need it

Short monolithic columns will deliver ultra-fast results at low back-pressure for isocratic and gradient applications: high sample throughput and fast column re-equilibration between analyses.

Chromolith® HighResolution RP-18e, 50–4.6 mm

Column	Chromolith® HighResolution RP-18e, 50–4.6 mm
Mobile phase	A: ACN B: 0.02 M Phosphate buffer pH 2.5
Gradient	0.0 min 20% A 0.3 min 40% A
Flow rate	3.5 mL/min
Column pressure	49–71 bar
LC system	LaChrom® L7000
Detection	UV 230 nm
Vol. detector cell	16 µL
Temperature	ambient
Injection volume	1 µL
Sample	1. Atenolol 2. Pindolol 3. Metoprolol 4. Bisoprolol 5. Labetalol 6. Propranolol

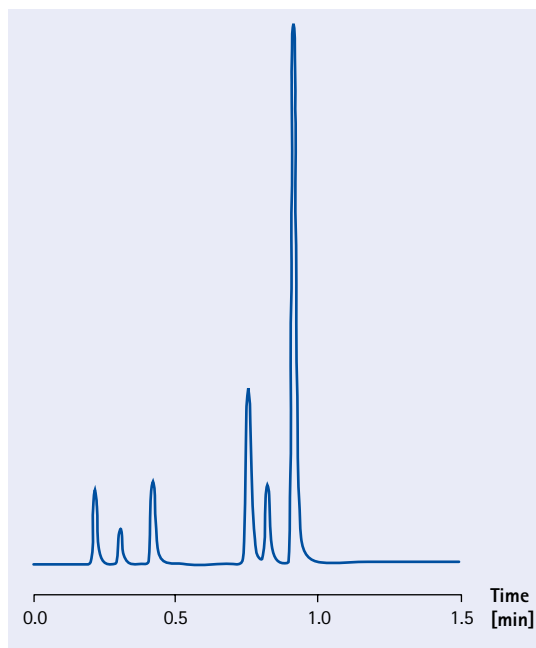

Chromolith® HighResolution RP-18e, 25–4.6 mm

Column	Chromolith® HighResolution RP-18e, 25–4.6 mm
Mobile phase	60% ACN / 40% water isocratic
Flow rate	2 mL/min
Column pressure	15 bar
Detection	UV 254 nm
Vol. detector cell	16 µL
Temperature	ambient
Injection volume	5 µL
Sample	1. Thiurea 2. Biphenyl-2-ol 3. Progesterone 4. Hexanophenone 5. Anthracene

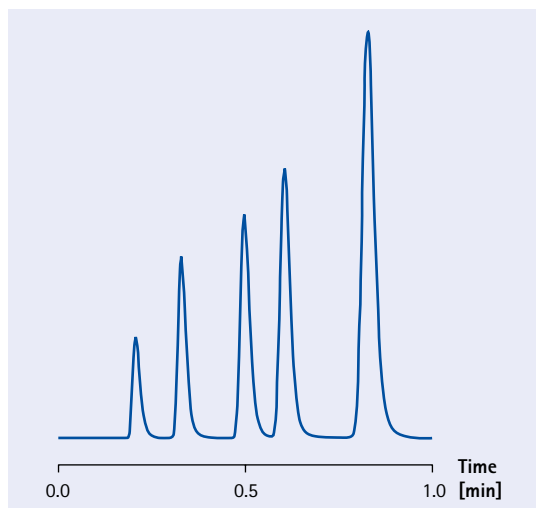

Increase the sensitivity and save solvents with 3 mm and 2 mm i.d. Chromolith® RP-18 endcapped products

Chromolith® RP-18 3 mm i.d. columns – fast separations at lower flow rates

The first figure shows a typical fast separation of four compounds in less than two minutes using a Chromolith® 4.6 mm internal diameter column at 4 mL/min. The second figure shows the same separation on Chromolith® 3 mm i.d. column with improved sensitivity and at just 1.7 mL/min, saving 57% solvents. Both chromatograms show excellent column efficiency and peak resolution.

Chromolith® Performance RP-18e 100–4.6 mm

Column	Chromolith® RP-18 endcapped 100–4.6 mm
Mobile phase	Acetonitrile / water 40/60
Flow rate	4.0 mL/min
Pressure	137 bar
Detection	UV 254 nm 2.4 µL flow cell
Temperature	ambient
Injection volume	1 µL
Sample	1. Biphenyl-4.4' -ol 2. Biphenyl-2.2' -ol 3. Biphenyl-4-ol 4. Biphenyl-2-ol

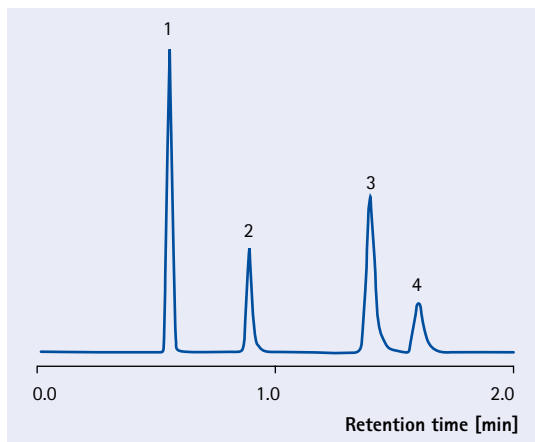

Chromolith® Performance RP-18e 100–3 mm

Column	Chromolith® RP-18 endcapped 100–4.6 mm
Mobile phase	Acetonitrile / water 40/60
Flow rate	1.7 mL/min
Pressure	100 bar
Detection	UV 254 nm 2.4 µL flow cell *
Temperature	ambient
Injection volume	1 µL *
Sample	1. Biphenyl-4.4' -ol 2. Biphenyl-2.2' -ol 3. Biphenyl-4-ol 4. Biphenyl-2-ol

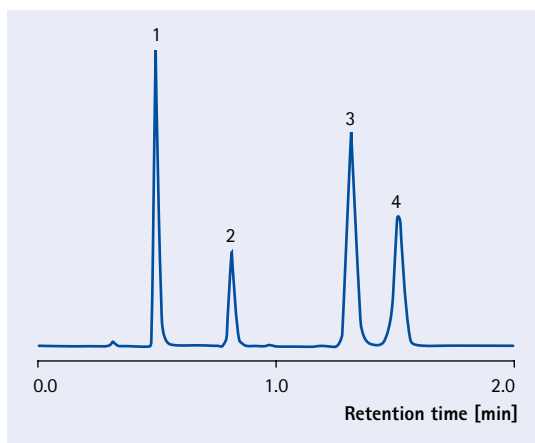

* For optimum results with 3 mm columns, extra-column volume must be small.



Chromolith® Performance
RP-18 endcapped 100–3 mm

Chromolith® RP-18 endcapped



Chromolith® Performance RP-18 endcapped 100 - 3 mm is an ideal alternative to conventional particulate columns with internal diameter 4.6, 4 or 3 mm. Even difficult separations, which often take 15 - 30 minutes on particulate columns, typically take only 5 - 10 minutes on Chromolith® 3 mm. Chromolith® 3 mm columns are easily coupled using the column coupler (1.51467.0001) to give columns 20 cm or longer as required. The result is shown below: very high peak resolution at moderate pressure with flow rates between 1-1.5 mL/min.

Chromolith® Performance RP-18e 100-3 mm

Column	Chromolith® Performance RP-18e 100-3 mm
Mobile phase	Acetonitrile / buffer pH 1.8 (gradient)
Flow rate	2.0 mL/min
Pressure	92 bar
Detection	UV 254 nm
Temperature	30°C
Injection volume	1 µL
Sample	1. - 2. by-products 3. Levothyroxine 4. - 9. by-products

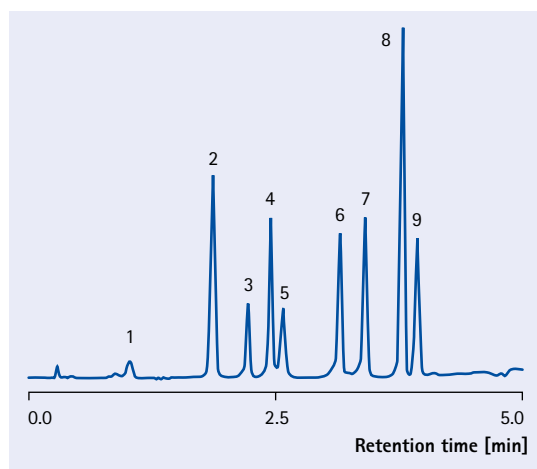

2 coupled Chromolith® Performance RP-18e 100-3 mm

Column	2 coupled Chromolith® Performance RP-18e 100-3 mm
Mobile phase	Acetonitrile / buffer pH 1.8 (gradient)
Flow rate	1.5 mL/min
Pressure	140 bar
Detection	UV 254 nm
Temperature	30°C
Injection volume	1 µL
Sample	1. - 2. by-products 3. Levothyroxine 4. - 9. by-products

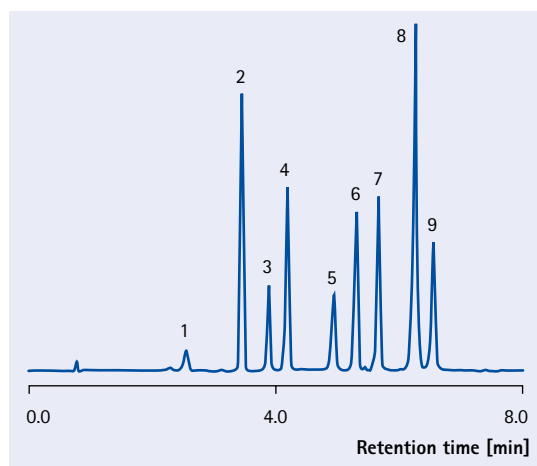

Two columns coupled together

Chromolith® RP-18 endcapped 2 mm i.d. columns – ultra high performance on any instrument

Ultra-high performance in combination with extraordinary low operating pressure makes the Chromolith® 2 mm column technology unique. Excellent "ultra-fast" results are obtained, not only in the new UHPLC and UPLC® instruments, but equally well in all standard HPLC systems with low dead volume. Chromolith® 2 mm columns have macropores with 1.5 µm diameter, giving a column efficiency exceeding 100,000 plates/meter. The mesopores are 13 nm (130 Å) and the surface modification is octadecylsilane with full endcapping.

Benefits at a glance

- **Flexibility** – this column gives very fast, high performance results with all low dead volume LC instruments, whether UHPLC, UPLC® or standard HPLC
- **Increase the sensitivity and save solvents** – compared to 4.6 mm i.d. column 81% of solvents is saved and 5.7 times higher sensitivity simultaneously achieved
- **Flow rates from 0.2 – 1 mL/min** give ideal compatibility with LC / MS systems, both with ESI and APCI interfaces
- **Long column lifetime and resistance to column blocking** – thanks to monolithic silica structure and absence of frits – gives method robustness and cost saving



Chromolith® Performance RP-18 100-4.6 mm

Column	Chromolith® Performance RP-18 endcapped 100-4.6 mm
Mobile phase	A: 100% Acetonitrile B: 100% Water + 0.1% TFA (v/v) C: 100% Methanol
Isocratic	Initial composition: A/B/C 30/60/10 (v/v/v)
Flow rate	2 mL/min
Pressure	45 bar (4.5 MPa, 65.3 psi)
Detection	Dionex Ultimate 3000 VWD-3400, 2.5 Hz, Response time 0.1 s, UV = 210 nm
Vol. detector cell	11 µL
Temperature	ambient
Injection volume	1 µL
Sample	Bimatoprost Bimatoprost free acid

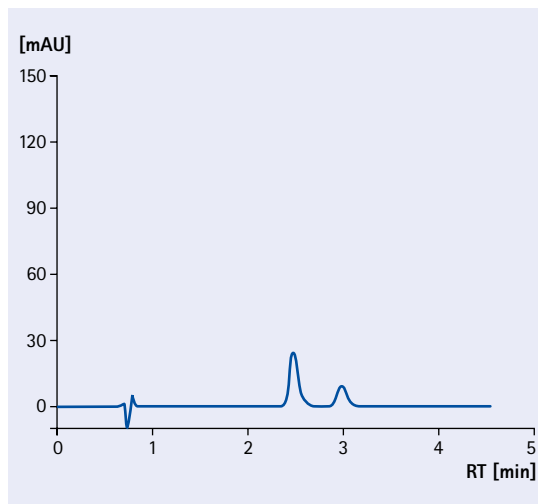

Chromolith® Performance RP-18 endcapped 100-2 mm

Column	Chromolith® Performance RP-18 endcapped 100-2 mm
Mobile phase	A: 100% Acetonitrile B: 100% Water + 0.05% TFA (v/v) C: 100% Methanol
Isocratic	Initial composition: A/B/C 30/60/10 (v/v/v)
Flow rate	380 µL/min
Pressure	48 bar (4.8 MPa, 70 psi)
Detection	Dionex Ultimate 3000 VWD-3400, 2.5 Hz, Response time 0.1 s, UV = 210 nm
Vol. detector cell	1.4 µL
Temperature	ambient
Injection volume	1 µL
Sample	Bimatoprost Bimatoprost free acid

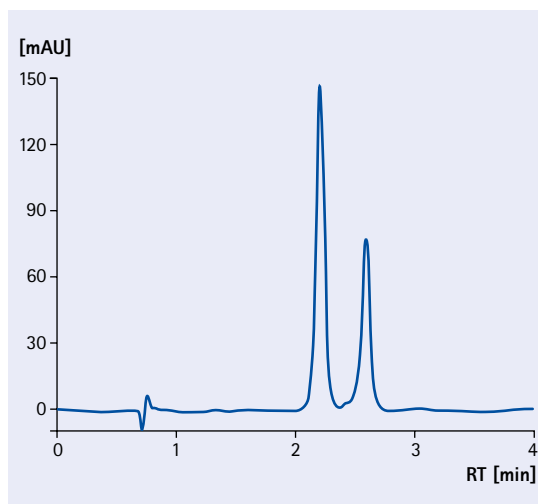

Separation examples

Separation of alkylphenones

Column	Chromolith® Performance RP-18 endcapped 100-2 mm		
Mobile phase	A: Acetonitrile B: Water		
Gradient	Time	%ACN	%Water
	0	15	85
	3.5	90	10
	5	90	10
	5.1	15	85
	6	15	85
Flow rate	0.38 mL/min		
Pressure	37-79 bar		
Detection	254 nm		
Temperature	ambient		
Injection volume	0.5 µL		
Sample	<ol style="list-style-type: none"> 1. Thiurea 2. Acetanilide 3. Acetophenone 4. Propiophenone 5. Benzophenone 6. Butyropenone 7. Valerophenone 8. Hexanophenone 9. Heptanophenone in ACN/Water 60/40 		

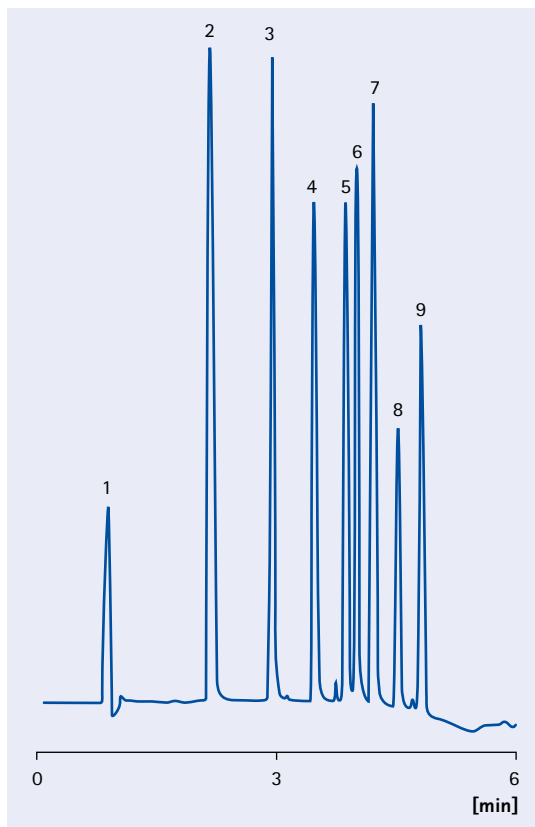

Ultra-fast separation of Antihistamines

Column	Chromolith® FastGradient RP-18e 50 - 2 mm		
Mobile phase	A: 0.1% TFA in water B: 0.1% TFA in ACN		
Gradient	5% to 90% B in 3.4 min		
Flow rate	1.0 mL/min		
Pressure	50 - 120 bar		
Detection	UV 230 nm		
Temperature	ambient		
Injection volume	0.2 µL		
Sample	<ol style="list-style-type: none"> 1. Phenylephrine 2. Tripelenamine 3. Pyrilamine 4. Chlorpheniramine 5. Brompheniramine 6. Chloropyramine 7. Diphenhydramine 8. Promethazine 9. Loratadine 10. Meclizine 		

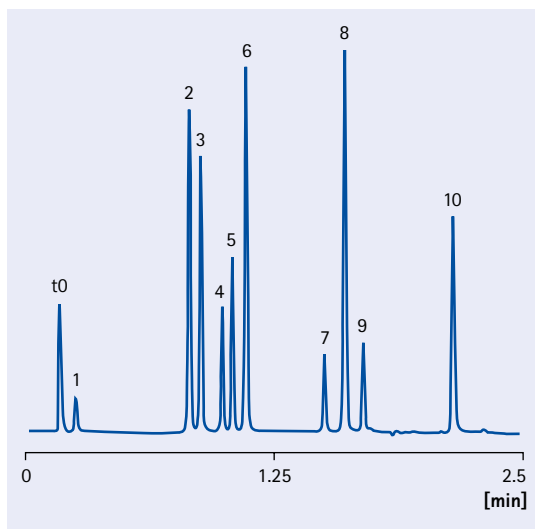

Chromolith® RP-18 endcapped

Fast separations: Carotenoids of Salmon Chromolith® Flash RP-18e 25-2 mm

Column	Chromolith® Flash RP-18 endcapped 25-2 mm		
Mobile phase	A: Acetonitrile B: Water + 0,1% Formic acid		
Gradient	Time	% ACN	% Water
	0	90	10
	3	50	50
Flow rate	1.14 mL/min		
Pressure	22-53 bar		
Detection	436 nm 11 µL flow cell		
Temperature	ambient		
Injection volume	5 µL		
Sample	1) Astaxanthin (cis + trans) 2) Canthaxanthin cis + trans) dissolved in Acetonitrile/Water + 0.1% Formic acid 2/1		

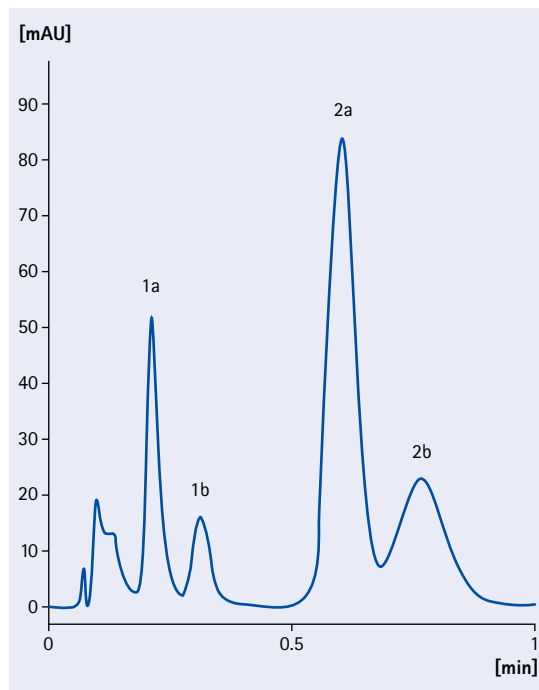

UHPLC system with
Chromolith® Performance RP-18e 100-2 mm
Bioflavonoid separation

Column	Chromolith® Performance RP-18 endcapped 100-2 mm			
Mobile phase	A: 0.1% TFA in H ₂ O B: MeOH			
Gradient	t	A	B	flow
	[min]	[%]	[%]	[mL/min]
	0.0	85	15	0.50
	2.5	50	50	0.50
	5.0	50	50	0.50
	5.1	85	15	0.50
	8.5	85	15	0.50
Detection	220 nm UV			
Temperature	ambient			
Injection volume	0.5 µL			
Sample	1. Isoquercetin 2. Troxerutin 3. Naringin 4. Morin 5. Quercetin 6. Trihydroxyethyluteolin			

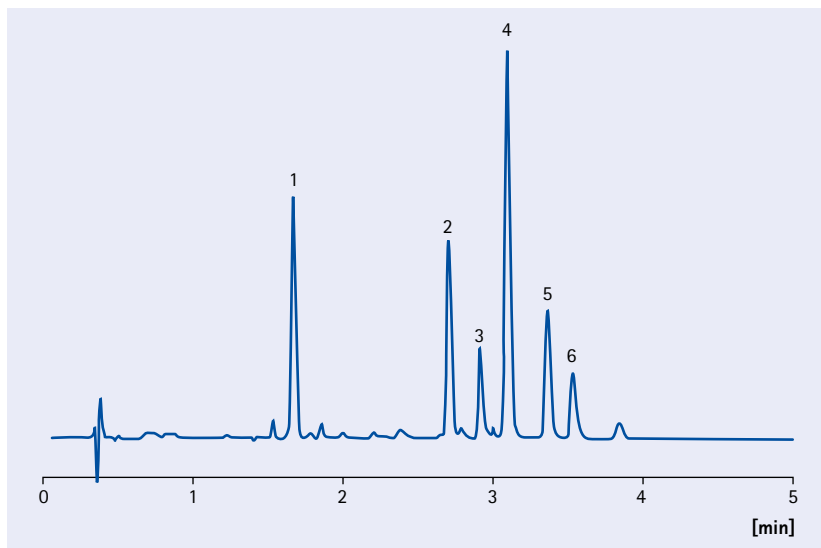

Application: Proteomics
Chromolith® Performance RP-18e 100-2 mm

Column	Chromolith® Performance RP-18 endcapped 100-2 mm
Mobile phase	A: 95% H ₂ O/5% ACN/0.1% TFA (v/v/v) B: 5% H ₂ O/95% ACN/0.085% TFA (v/v/v)
Gradient	from 5% B to 50% B in 20 min
Flow rate	0.3 mL/min
Detection	UV 214 nm
Sample	1 µL BSA digest (1 mg/mL)

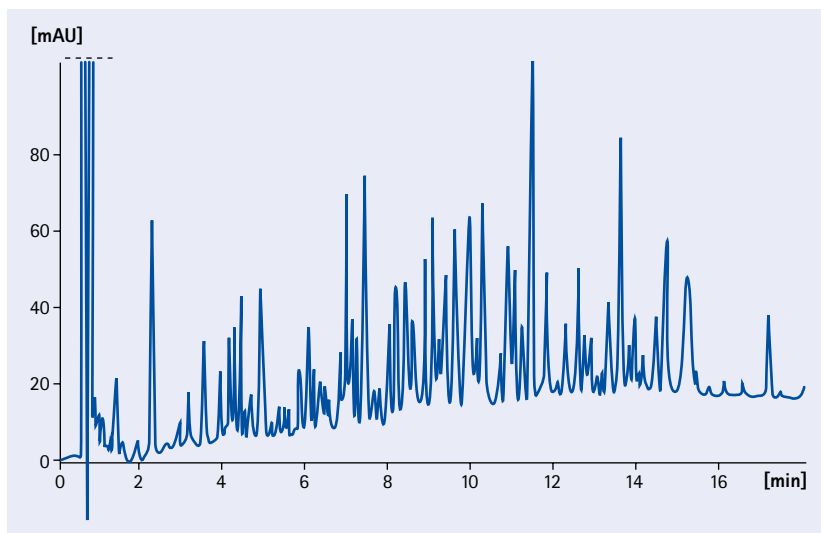

Chromolith® RP-8 endcapped

The Chromolith® RP-8 endcapped HPLC columns offer all the benefits of the monolithic silica technology for reversed phase chromatography:

- high throughput at high flow rates with the best overall column quality
- the possibility of flow gradients
- added column performance by column coupling
- a rigid structure for a longer lifetime
- less matrix-sensitivity

In contrast to the most commonly used reversed phase columns, the Chromolith® RP-18 endcapped, the Chromolith® RP-8 endcapped with its shorter alkyl chain offers less retention and a slightly different selectivity. Therefore it is possible that a baseline separation can be achieved on the RP-8 endcapped bonded column whereas no separation at all is observed under identical elution conditions on a RP-18 endcapped bonded silica column.

Specifications of Chromolith® RP-8 endcapped

Silica type	High-purity
Particle size	Monolithic
Macropore size	2 µm
Mesopore size	13 nm (130 Å)
Pore volume	1 mL/g
Total porosity	> 80%
Surface area	300 m ² /g
Surface modification	RP-8 endcapped
Carbon content	11%

Ordering information – Chromolith® RP-8 endcapped

Product	Ordering No.	Dimension length	Dimension diameter	Contents of one package
Chromolith® Performance RP-8 endcapped	1.51468.0001	100 mm	4.6 mm	1 piece

▶ Chromolith® CapRod®
Monolithic capillary
page 161

▶ Chromolith® RP-18
endcapped Chromolith®
RP-18 endcapped columns are the fastest C18
columns in the world.
page 172

▶ Chromolith® Si
page 190

▶ Chromolith®
guard cartridges and
cartridge kit
page 195

▶ Chromolith® column
coupler
page 198

▶ Chromolith® SemiPrep
Perfect scale-up from
analytical to preparative
LC
page 200

Separation examples on Chromolith® Performance RP-8 endcapped 100–4.6 mm

Column	Chromolith® Performance RP-8 endcapped, 100–4.6 mm	
Mobile phase	A: Acetonitrile/ water 90/ 10 + 0.1% TFA B: 0.1% TFA in water	
Gradient	Time/min	%A %B
	0.0	45 55
	1.0	90 10
	3.0	90 10
Flow rate	2 mL/min	
Pressure	30 - 40 bar	
Detection	214 nm	
Temperature	ambient	
Injection volume	30 µL	
Sample	1. (Sar1, Ala8)-Angiotensine II	87 µg/mL
	2. (Sar1, Ile8)-Angiotensine II	87 µg/mL
	3. Angiotensine I	47 µg/mL

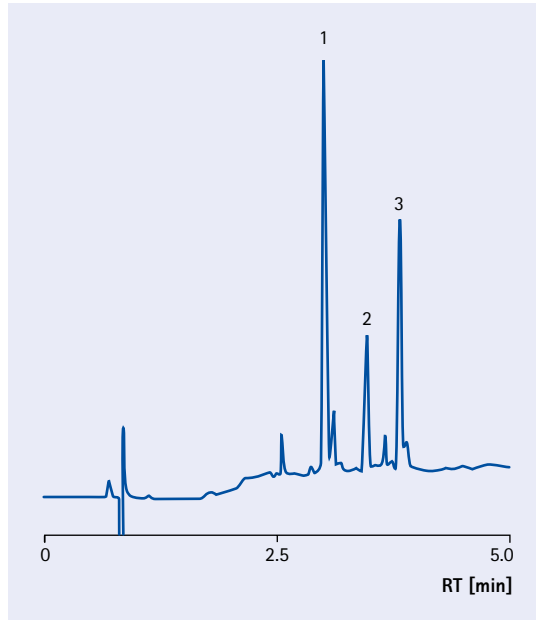

Chromolith® Performance RP-8 endcapped 100–4.6 mm

Column	Chromolith® Performance RP-8 endcapped, 100–4.6 mm	
Mobile phase	A: Acetonitrile B: 20mM NaH ₂ PO ₄ pH 2.5	
Gradient	Time/min	% A
	0	2
	0.5	18
	8.5	18
	9.1	32
	16	32
Flow rate	1 mL/min	
Pressure	23 bar	
Detection	220 nm	
Temperature	ambient	
Injection volume	5 µL	
Sample	1. Malic acid	0.92 mg/mL
	2. Succinic acid	1.70 mg/mL
	3. Glutaric acid	1.20 mg/mL
	4. 3,4-Dihydroxy-cinnamic acid	0.02 mg/mL
	5. 4-Hydroxy-cinnamic acid	0.03 mg/mL
	6. Sorbic acid	0.20 mg/mL
	7. Benzoic acid	0.04 mg/mL
	8. 2-Hydroxybenzoic acid	0.15 mg/mL
	9. Cinnamic acid	0.04 mg/mL

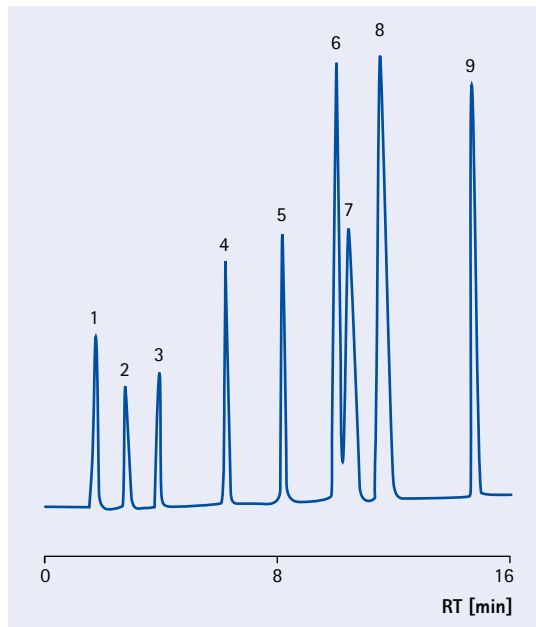

Chromolith® Si

Based on a high-purity silica, Chromolith® Si has been developed as a monolithic normal-phase material suitable for separating polar non-ionic organic compounds, but with all of the benefits of the monolithic silica technology:

- high throughput at high flow rates with the best overall column quality
- the possibility of flow gradients
- added column performance by column coupling
- a rigid monolithic structure for a longer lifetime
- less matrix-sensitivity



► **Chromolith® CapRod®**
Monolithic capillary
page 161

► **Chromolith® RP-18 endcapped** Chromolith® RP-18 endcapped columns are the fastest C18 columns in the world.
page 172

► **Chromolith® RP-8 endcapped**
page 188

► **Chromolith® guard cartridges and cartridge kit**
page 195

► **Chromolith® column coupler**
page 198

► **Chromolith® SemiPrep**
Perfect scale-up from analytical to preparative LC
page 200

► **Chromolith® Prep**
Chromolith® – increase in speed, efficiency and productivity
page 204

Specifications of Chromolith® Si

Silica type	High-purity
Particle size	Monolithic
Macropore size	2 µm
Mesopore size	13 nm (130 Å)
Pore volume	1 mL/g
Total porosity	> 80%
Surface area	300 m ² /g

Ordering information – Chromolith® Si

Product	Ordering No.	Dimension length	Dimension diameter	Contents of one package
Chromolith® Performance Si	1.51465.0001	100 mm	4.6 mm	1 piece

Separation examples on Chromolith® Performance Si 100–4.6 mm

Column	Chromolith® Performance Si 100–4.6 mm	
Mobile phase	n-Heptane/Dioxane 95/5 v/v	
Flow rate	2 mL/min	
Pressure	14 bar	
Detection	254 nm	
Temperature	ambient	
Injection volume	5 µL	
Sample	1. Anisole	0.39 mg/mL
	2. 3-Nitroanisole	0.07 mg/mL
	3. 4-Nitroanisole	0.26 mg/mL
	4. 2-Nitroanisole	0.18 mg/mL

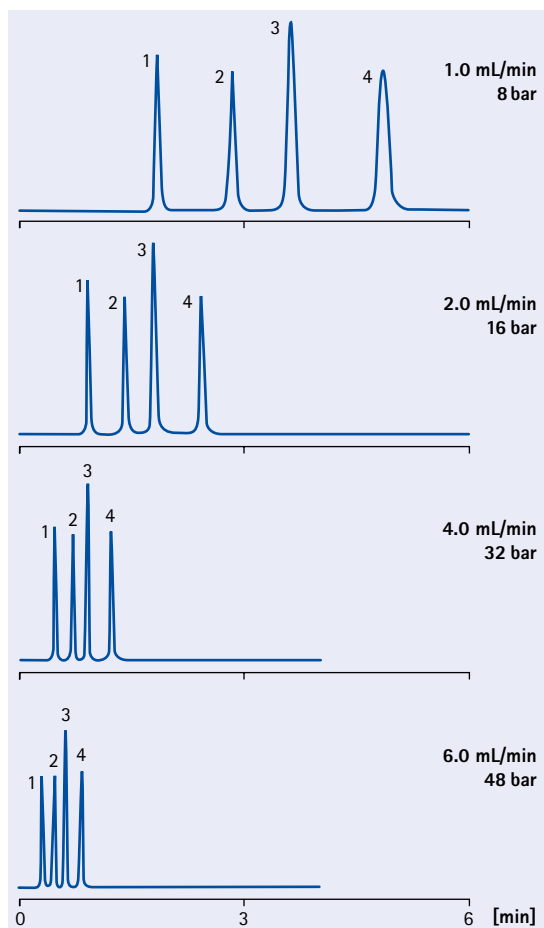

Chromolith® Performance Si 100–4.6 mm

Column	Chromolith® Performance Si 100–4.6 mm	
Mobile phase	n-Heptane/Dioxane 95/5 v/v	
Flow rate	2 mL/min	
Pressure	14 bar	
Detection	254 nm	
Temperature	ambient	
Injection volume	10 µL	
Sample	1. Toluene	0.16 mg/mL
	2. Nitrobenzene	0.02 mg/mL
	3. 2,3-Dimethylantraquinone	0.02 mg/mL
	4. 2-Nitroacetanilide	0.10 mg/mL

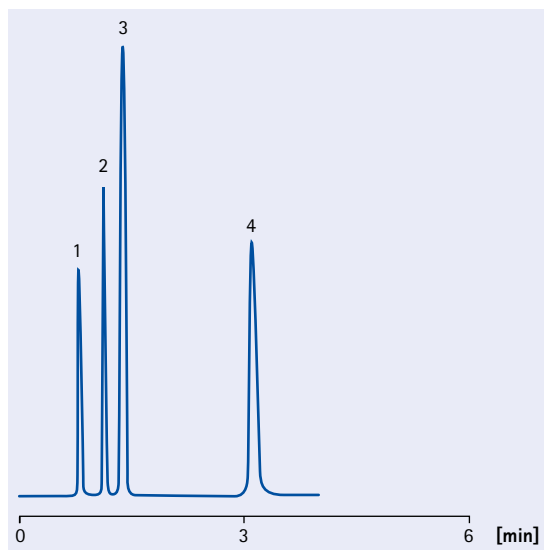

Chromolith® NH₂

Aminopropyl-modified Chromolith® columns in terms of polarity lie between bare silica (normal-phase chromatography) and reversed-phase silica (reversed-phase chromatography) also can already be used as an ion-exchanger. In acidic solutions the NH₂-groups are protonated (-NH₃⁺X⁻) and therefore display the characteristics of a weak anion exchanger. Medium polar Chromolith® NH₂ column possess hydrophilic as well as hydrophobic properties and can be used under both reversed-phase and normal phase conditions. Retention however, is weaker than on silica and on RP-supports.

Chromolith® NH₂ columns are made of highly porous monolithic rods of silica with a revolutionary bimodal pore structure, therefore high separation efficiencies are reached under low back-pressures. Chromolith® NH₂ column have long lifetimes within pH range of 2.5 to 7.5, high matrix tolerance and speed of analysis.

The major application area for amino-phases is the separation of carbohydrates (mono- and disaccharides such as fructose, glucose, sucrose, maltose, and lactose), anions and organic acids. These columns may be used for normal phase chromatography, reversed phase chromatography, and weak anion exchange separations.

Specifications of Chromolith® NH₂

Silica type	High-purity
Particle size	Monolithic
Macropore size	2 µm
Mesopore size	13 nm (130 Å)
Pore volume	1 mL/g
Total pore volume	3.2 mL/g
Surface area	300 m ² /g
Surface modification	aminopropyl

Ordering information – Chromolith® NH₂

Product	Ordering No.	Dimension length	Dimension diameter	Contents of one package
Chromolith® Performance NH ₂	1.52028.0001	100 mm	4.6 mm	1 piece
Chromolith® SpeedROD NH ₂	1.52027.0001	50 mm	4.6 mm	1 piece
Chromolith® Flash NH ₂	1.52026.0001	25 mm	4.6 mm	1 piece

Separation examples on Chromolith® Performance NH₂ 100–4.6 mm

Column	Chromolith® Performance NH ₂ 100–4.6 mm	
Mobile phase	A: 100% Acetonitrile (v/v) B: 100% Water (v/v) C: 0.05 M Phosphat buffer pH 4.6 (v/v)	
Gradient	Initial composition: 86% A + 9% B + 5% C	for 2 min
	Change to: 80% A + 10% B + 10% C	in 1 min
	Hold	until 10 min
Flow rate	1 mL/min	
Pressure	24–28 bar (2.8 MPa, 40696 psi)	
Detection	Dionex Ultimate 3000 VWD–3400, 2.5 Hz, response time 0.1s, UV = 265 nm 11 µL flow cell	
Temperature	25°C	
Injection volume	5 µL	
Sample	1. Uracil-β-D-arabinofuranoside 2. Uridine 3. Cytosine-β-D-arabinofuranoside 4. Cytidine	

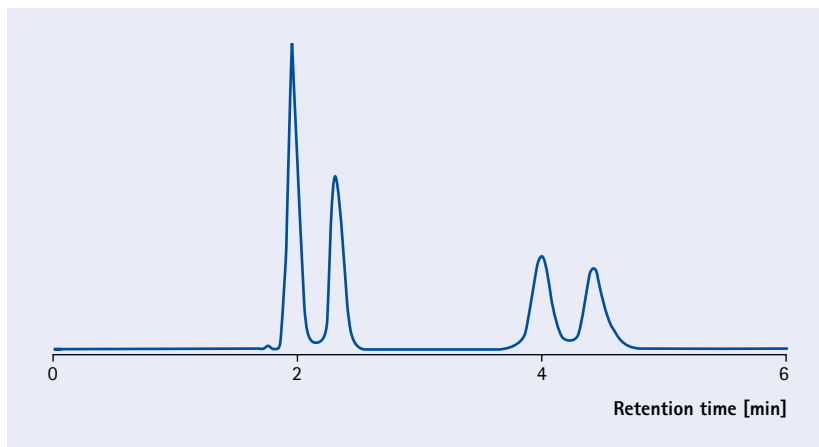
Chromolith® Performance NH₂ 100–4.6 mm

Column	Chromolith® Performance NH ₂ 100–4.6 mm	
Mobile phase	A: 100% Acetonitrile (v/v) B: 100% Water (v/v) C: 20 mM Phosphat buffer pH 3.0 (v/v)	
Isocratic	Initial composition: 85% A / 5% B / 10% C v/v/v isocratic	
Flow rate	4 mL/min	
Pressure	100 bar (10 MPa, 145 psi)	
Detection	Dionex Ultimate 3000 VWD–3400, 2.5Hz, response time 0.1s, UV 210 nm 11 µL flow cell	
Temperature	40°C	
Injection volume	1 µL	
Sample	1. Norepinephrine 2. Epinephrine tartrate 3. Dopamine 4. DOPA 5. Norephedrine 6. N-Methylephedrine	

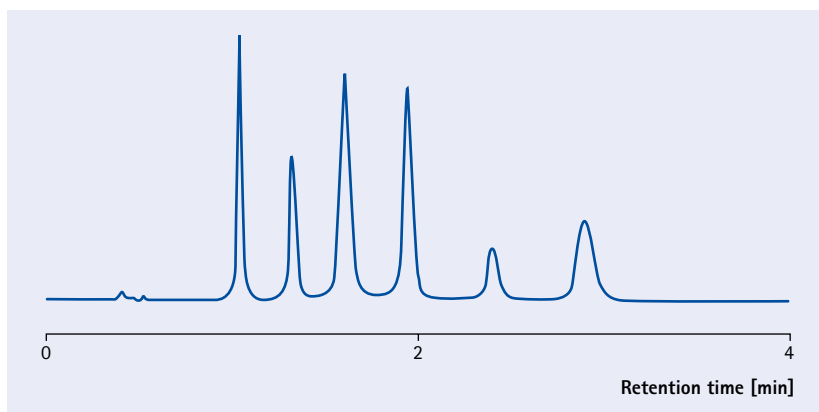

Separation examples on Chromolith® Performance NH₂ 100–4.6 mm

Column	Chromolith® Performance NH ₂ 100–4.6 mm
Mobile phase	A: 100% Acetonitrile (v/v) B: 100% Water (v/v)
Isocratic	Initial composition 75% A / 25% B (v/v) isocratic
Flow rate	1 mL/min
Pressure	11 bar (1.1 MPa, 16 psi)
Detection	Dionex Ultimate 3000 VWD-3400, 2.5Hz, response time 0.1s, UV 190 nm 11 µL flow cell
Temperature	23°C
Injection volume	10 µL
Sample	1. Xylose 2. Fructose 3. Glucose 4. Saccharose

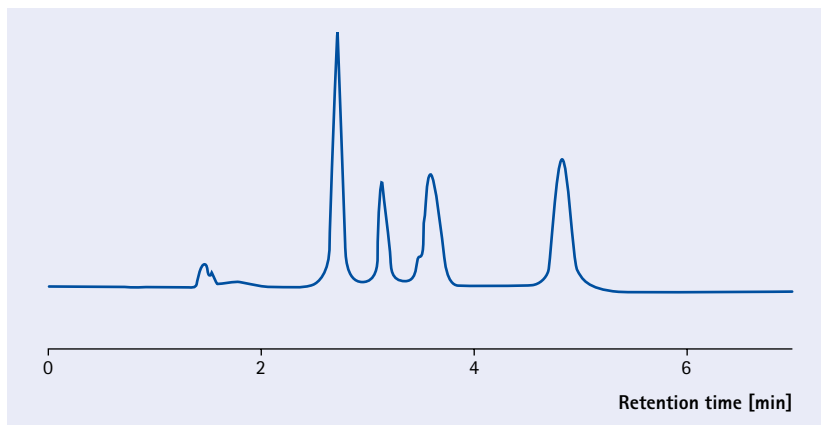

Chromolith® Performance NH₂ 100–4.6 mm

Column	Chromolith® Performance NH ₂ 100–4.6 mm
Mobile phase	A: 100% Acetonitrile (v/v) B: 100% Ammonium acetate 100 mM pH 6.8 (v/v)
Isocratic	Initial composition: 90% A / 10% B (v/v)
Flow rate	4 mL/min
Pressure	108 bar (10.8 MPa, 157psi)
Detection	Dionex Ultimate 3000 VWD-3400, 2.5Hz, response time 0.1s, UV 240 nm 11 µL flow
Temperature	25°C
Injection volume	5 µL
Sample	1. Ascorbic acid 2. Dehydroascorbic acid

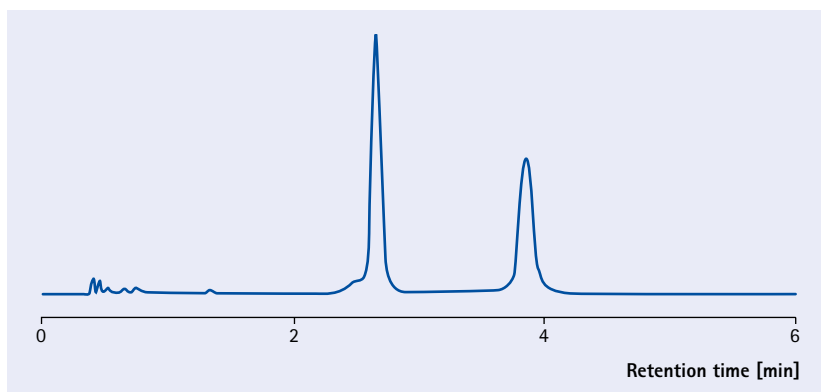

Chromolith® HPLC guard cartridges and cartridge kits

Although the monolithic columns are well-known for their robustness and longevity, guard columns are available to protect these analytical columns even further. The guard columns are suitable for reversed-phase chromatography since they are chemically modified with hydrophobic n-octadecyl (C18) groups on the surface of the monolithic silica rod. A guard column directly in front of the main column protects the column against contamination of a chemical or mechanical nature. Guard columns should be frequently changed in order to avoid excessive accumulation of impurities. The monolithic guard columns are very easy to use. Due to the general benefits of the monolithic technology and the easy handling the Chromolith® guard columns, they are also popular for the protection of classical packed columns.

The cartridge kit is the starter kit which includes the guard cartridge holder. The guard cartridges are available in two different lengths: 5 mm and 10 mm.



Guard cartridges in 5 mm and 10 mm length



- ▶ **Chromolith® CapRod®**
Monolithic capillary
page 161
- ▶ **Chromolith® RP-18 endcapped** Chromolith® RP-18 endcapped columns are the fastest C18 columns in the world.
page 172
- ▶ **Chromolith® RP-8 endcapped**
page 188
- ▶ **Chromolith® Si**
page 190
- ▶ **Chromolith® column coupler**
page 198
- ▶ **Chromolith® SemiPrep**
Perfect scale-up from analytical to preparative LC
page 200

Chromolith® HPLC guard cartridges and cartridge kits

Ordering information – Chromolith® RP-18 endcapped guard cartridges

Product	Ordering No.	Column length	Column diameter	Contents of one package
Chromolith® guard cartridge RP-18 endcapped	1.51452.0001	10 mm	4.6 mm	3 guard cartridges
Chromolith® guard cartridge kit RP-18 endcapped	1.51471.0001	10 mm	4.6 mm	1 starter kit with holder and 3 guard cartridges
Chromolith® guard cartridge RP-18 endcapped	1.51451.0001	5 mm	4.6 mm	3 guard cartridges
Chromolith® guard cartridge kit RP-18 endcapped	1.51470.0001	5 mm	4.6 mm	1 starter kit with holder and 3 guard cartridges
Chromolith® HighResolution guard cartridge RP-18 endcapped	1.52025.0001	5 mm	4.6 mm	3 guard cartridges
Chromolith® HighResolution guard cartridge kit RP-18 endcapped	1.52024.0001	5 mm	4.6 mm	1 starter kit with holder and 3 guard cartridges
Chromolith® guard cartridge RP-18 endcapped	1.52005.0001	5 mm	3 mm	3 guard cartridges
Chromolith® guard cartridge kit RP-18 endcapped	1.52004.0001	5 mm	3 mm	1 starter kit with holder and 3 guard cartridges
Chromolith® guard cartridge RP-18 endcapped	1.52009.0001	5 mm	2 mm	3 guard cartridges
Chromolith® guard cartridge kit RP-18 endcapped	1.52008.0001	5 mm	2 mm	1 starter kit with holder and 3 guard cartridges

Ordering information – Chromolith® RP-8e guard cartridges

Product	Ordering No.	Column length	Column diameter	Contents of one package
Chromolith® guard cartridge RP-8e	1.52013.0001	5 mm	4.6 mm	3 guard cartridges
Chromolith® guard cartridge kit RP-8e	1.52012.0001	5 mm	4.6 mm	1 starter kit with holder and 3 guard cartridges

Ordering information – Chromolith® NH₂ guard cartridges

Product	Ordering No.	Column length	Column diameter	Contents of one package
Chromolith® guard cartridge NH ₂	1.52030.0001	5 mm	4.6 mm	3 guard cartridges
Chromolith® guard cartridge kit NH ₂	1.52029.0001	5 mm	4.6 mm	1 starter kit with holder and 3 guard cartridges

Ordering information – Chromolith® Si guard cartridges

Product	Ordering No.	Column length	Column diameter	Contents of one package
Chromolith® guard cartridge Si	1.52011.0001	5 mm	4.6 mm	3 guard cartridges
Chromolith® guard cartridge kit Si	1.52010.0001	5 mm	4.6 mm	1 starter kit with holder and 3 guard cartridges

Separation examples on Chromolith® Performance RP-18e 100-2 mm with precolumn Chromolith® RP-18e 5-2 mm

Column	Chromolith® Performance RP-18e 100-2 mm with precolumn Chromolith® RP-18e 5-2 mm	
Mobile phase	Acetonitrile/ water 60/40	
Flow rate	0.38 mL/min	
Pressure	20 bar	
Detection	UV 254 nm	
Anthracene	N/m	113540
	T _{USP}	1.14
	K'-value	3.79
Sample	<ol style="list-style-type: none"> 1. Thiourea 2. Biphenyl-2-ol 3. Progesterone 4. Hexanophenone 5. Anthracene 	

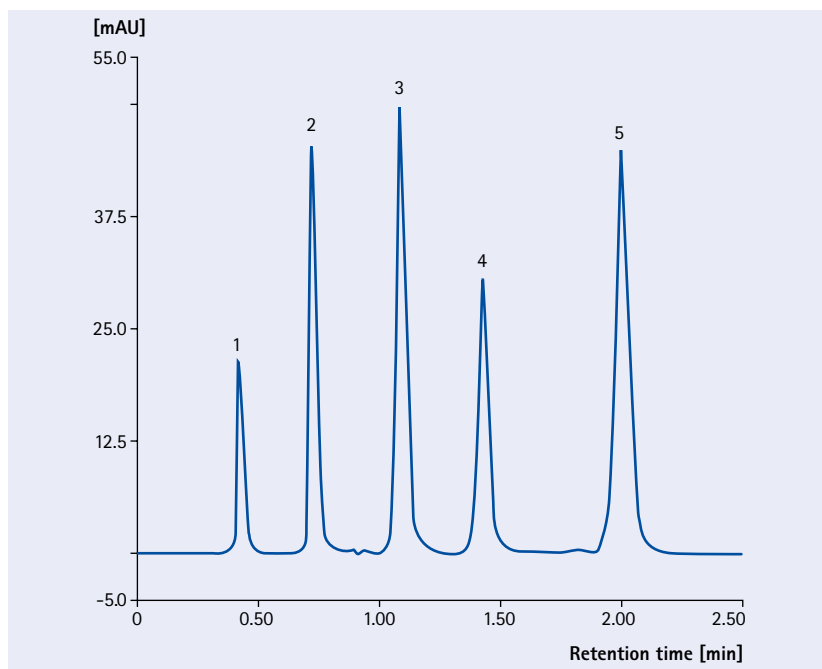

Chromolith® Performance RP-18e 100-2 mm without precolumn

Column	Chromolith® Performance RP-18e 100-2 mm without precolumn	
Mobile phase	Acetonitrile/ water 60/40	
Flow rate	0.38 mL/min	
Pressure	20 bar	
Detection	UV 254 nm	
Anthracene	N/m	115460
	T _{USP}	1.07
	K'-value	3.90
Sample	<ol style="list-style-type: none"> 1. Thiourea 2. Biphenyl-2-ol 3. Progesterone 4. Hexanophenone 5. Anthracene 	

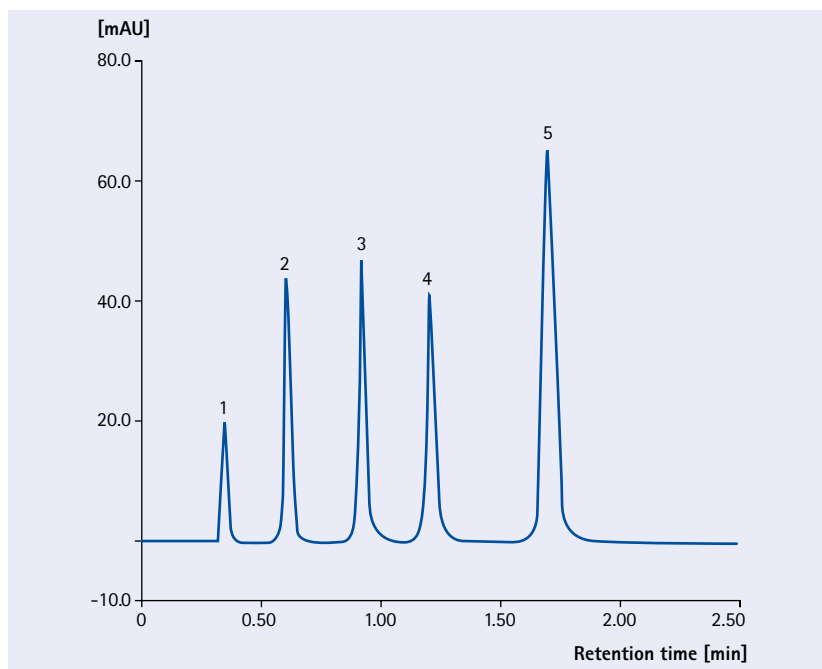

Chromolith® column coupler

Chromolith® Performance RP-18 endcapped columns provide rapid high quality separation of complex mixtures. But, if necessary, the separation efficiency can be increased by coupling several columns together using the Chromolith® column coupler. With the column coupler it is possible to increase the plate count by coupling several columns in series producing a column with a theoretical plate count which is significantly higher compared to any particulate column available, while producing pressures still well below the HPLC system limit. This added column performance is the key to solve even very critical separation problems where resolution is the limiting factor! Therefore they are perfect for use to separate formerly non-separable complex mixtures.

The table below shows the comparison between Chromolith® columns and particulate columns. As you can clearly see, the combination of two Chromolith® Performance RP-18 endcapped columns (linked by a column coupler) will result in a column with a separation efficiency of 19,000 theoretical plates per column, which is usually the maximum for particulate columns.

Typical column efficiency using the Chromolith® column coupler

Column	Length [mm]	Pressure * [bar]	Plate number per column [Anthracene]
Chromolith® Performance 1x	100	30	10,000
Chromolith® Performance 2x	200	60	19,000
Chromolith® Performance 3x	300	90	27,000
Chromolith® Performance 4x	400	120	35,000
Chromolith® Performance 5x	500	150	41,000
Particulate column (5 µm)	250	220	18,500
Particulate column (3.5 µm)	150	400	19,000

Pressure * 3 mL/min 75% acetonitrile, 25% water

Ordering information – Chromolith® column coupler

Product	Ordering No.	Contents of one package
Chromolith® column coupler	1.51467.0001	1 column coupler



Column coupler

Application of Chromolith® column coupler 81,000 plates at 85 bar pressure

Column	10 columns of Chromolith® Performance RP-18e, 100-4.6 mm
Mobile phase	80 /20 Acetonitrile/water
Flow rate	1 mL/min
Detection	UV 254 nm
Temperature	ambient
Injection volume	10 µL
Sample	1. Thiourea 2. Benzene 3. Toluene 4. Ethylbenzene 5. Propylbenzene 6. Butylbenzene 7. Penylbenzene

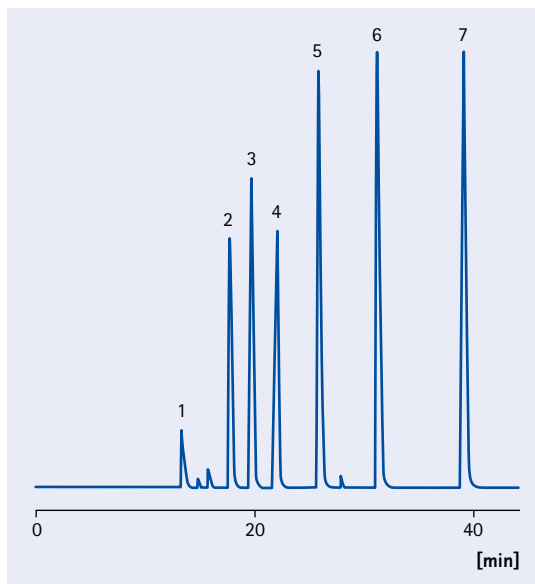

Column coupling: 11 steroids Chromolith® HighResolution RP-18e 2 x 100-4.6 mm / 1 x 50-4.6 mm

Column	Chromolith® HighResolution RP-18e 2 x 100-4.6 mm / 1 x 50-4.6 mm		
Mobile phase	ACN / water		
Gradient	t [min]	ACN [%]	Water [%]
	0	55	45
	2	95	5
	15	95	5
Flow rate	1 mL/ min		
Column pressure	30 - 68 bar		
LC system	LaChrom® L7000		
Detection	UV = 240 nm		
Vol. detector cell	16 µL		
Temperature	ambient		
Injection volume	10 µL		
Sample	1. Fluoxymesterone 2. Boldenone 3. Methandrostenolone 4. Testosterone 5. Methyltestosterone 6. Boldenone-Acetate 7. Testosterone-Acetate 8. Nandrolone-Propionate 9. Testosterone-Propionate 10. Nandrolone-Phenylpropionate 11. Testosterone-Isocaproate		

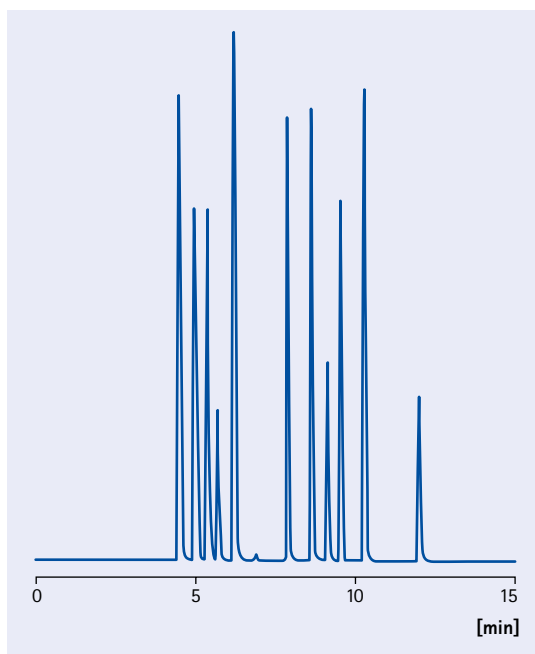

Chromolith® SemiPrep

Perfect scale-up from analytical to preparative LC

Optimum separation at flow rates exceeding 40 mL/min

Chromolith® SemiPrep 10 mm i.d. columns combine high separation speed with very high separation performance. They are the ideal alternative to particulate columns with 10 mm i.d. (and even 21.2 mm). The Chromolith® SemiPrep columns have the same bimodal porous silica rod structure as the Chromolith® analytical columns with 4.6 mm inner diameter. The macropores are 2 µm diameter and the mesopores are 13 nm.

Chromolith® SemiPrep benefits

- Direct scale-up from analytical to semi-prep
- Faster sample throughput at lower operating pressure compared to semi-prep columns packed with 5 µm particles
- Sharp separations, even at high sample loading
- Excellent column lifetime, thanks to rugged monolithic silica structure
- Chromolith® SemiPrep columns are optimized for LC/MS by a surface modification process minimizing column bleed.

Specifications of Chromolith® SemiPrep 100–10 mm

Silica type	High-purity (99.999%)
Particle size	Monolithic
Macropore size	2 µm
Mesopore size	13 nm (130 Å)
Pore volume	1.0 mL/g
Total porosity	> 80%
Surface area	300 m ² /g
Surface modification	RP-18 endcapped
Selectivity equivalent to	L1 (USP)
Carbon content	18%
Surface coverage	3.6 µmol/m ²
Mobile phase compatibility	all standard HPLC solvents may be used with the following restrictions
Max. dichloromethane conc.	5%
Max. tetrahydrofuran conc.	50%
Max. dimethylsulphoxide DMSO	5% but OK as sample solvent
pH range	2 – 7.5
Max pressure	150 bar for 10 mm columns
Max temperature	45°C

▶ Chromolith® CapRod®
Monolithic capillary
page 161

▶ Chromolith® RP-18
endcapped Chromolith®
RP-18 endcapped columns are the fastest C18
columns in the world.
page 172

▶ Chromolith® RP-8
endcapped
page 188

▶ Chromolith® Si
page 190

▶ Chromolith®
guard cartridges and
cartridge kit
page 195

▶ Chromolith® column
coupler
page 198

▶ Chromolith® Prep
Chromolith® – increase
in speed, efficiency and
productivity
page 204

Ordering information – Chromolith® SemiPrep 100–10 mm

Product	Ordering No.	Dimension length	Dimension diameter	Contents of one package
Chromolith® SemiPrep Si	1.52015.0001	100 mm	10 mm	1 piece
Chromolith® SemiPrep RP-18 endcapped	1.52016.0001	100 mm	10 mm	1 piece
Chromolith® SemiPrep Si guard cartridge	1.52035.0001	10 mm	10 mm	1 piece
Chromolith® SemiPrep RP-18 endcapped guard cartridge	1.52036.0001	10 mm	10 mm	1 piece
Chromolith® SemiPrep guard cartridge holder	1.52037.0001	10 mm	10 mm	1 piece



Optimum separation at flow rates exceeding 40 mL/min

Chromolith® SemiPrep RP-18e 100–10 mm i.d. columns combine high separation speed with very high separation performance. They are the ideal alternative to particulate columns with 10 mm i.d. (and even 21.2 mm).

Separation of a standard mixture

Acetonitrile/water 60/40, Data for anthracene (3rd peak)

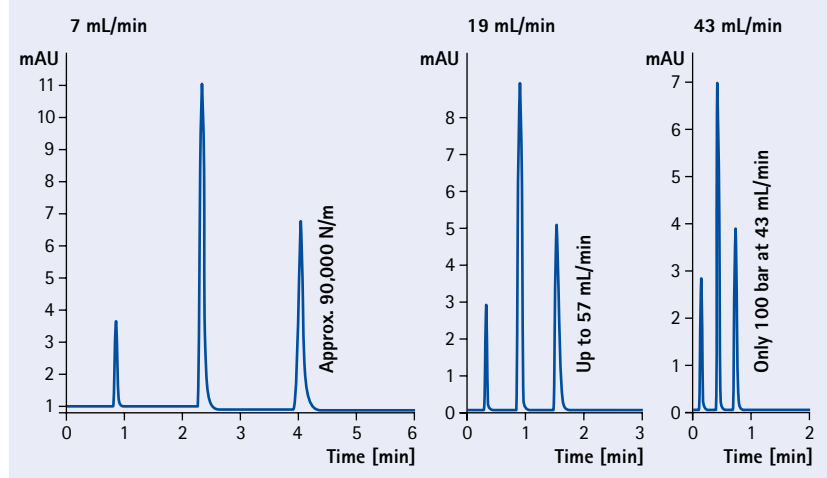

Mobile phase	Acetonitrile/water 60/40
Flow rate	2 mL/min
Detection	UV 254 nm
Temp.	ambient
Injection volume	5 µL
Sample	1. Thiourea 2. Progesterone 3. Anthracene

Accurate scale-up from analytical to preparative columns

25 mg injected onto a Chromolith® SemiPrep RP-18 endcapped column show the same excellent separation when compared with the corresponding analytical column.

Chromolith® Performance RP-18 endcapped 100-4.6 mm

Column	Chromolith® Performance RP-18 endcapped 100-4.6 mm	
Mobile phase	A: Acetonitrile with 0.1% TFA B: Water with 0.1% TFA	
Gradient	0 – 10 min	15 – 80% A
Flow rate	1 mL/min	
Detection	UV 270 nm	
Injection volume	2 µL	
Sample	1. Nadolol	1 mg/mL
	2. Metoprolol	1 mg/mL
	3. Propranolol	0.5 mg/mL

Chromolith® SemiPrep RP-18 endcapped 100-10 mm

Column	Chromolith® SemiPrep RP-18 endcapped 100-10 mm	
Mobile phase	A: Acetonitrile with 0.1% TFA B: Water with 0.1% TFA	
Gradient	0 – 10 min 15 – 80% A	
Flow rate	4.7 mL/min	
Detection	UV 270 nm	
Injection volume	100 µL	
Sample	1. Nadolol	100 mg/mL
	2. Metoprolol	100 mg/mL
	3. Propranolol	50 mg/mL

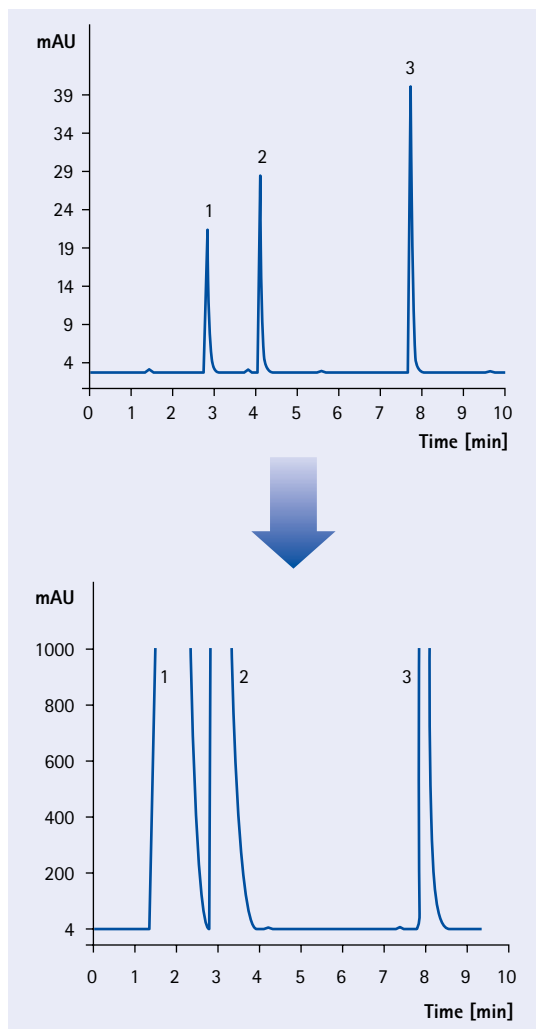

Sample loadability

The sample loadability depends on many factors including the solubility of the sample in the mobile phase.

The following example shows that the sample loadability on the Chromolith® SemiPrep column can exceed 80 mg. Here DMSO is used as solvent.

Chromolith® SemiPrep RP-18 endcapped 100–10 mm

Column	Chromolith® SemiPrep RP-18 endcapped 100–10 mm	
Mobile phase	A: Acetonitrile with 0.05% TFA B: Water with 0.05% TFA	
Gradient	0 – 1 min	5% A
	1 – 5 min	5 – 90% A
	5 – 5.2 min	95% A
	5.2 – 6.2 min	95% A
Flow rate	8 mL/min	
Detection	UV 214 nm	
Injection volume	400 µL	
Sample	1. Propranolol	200 mg/mL
	2. Nifedipine	200 mg/mL
	dissolved in DMSO/Methanol 1/1	

Separation of 80 mg/injection

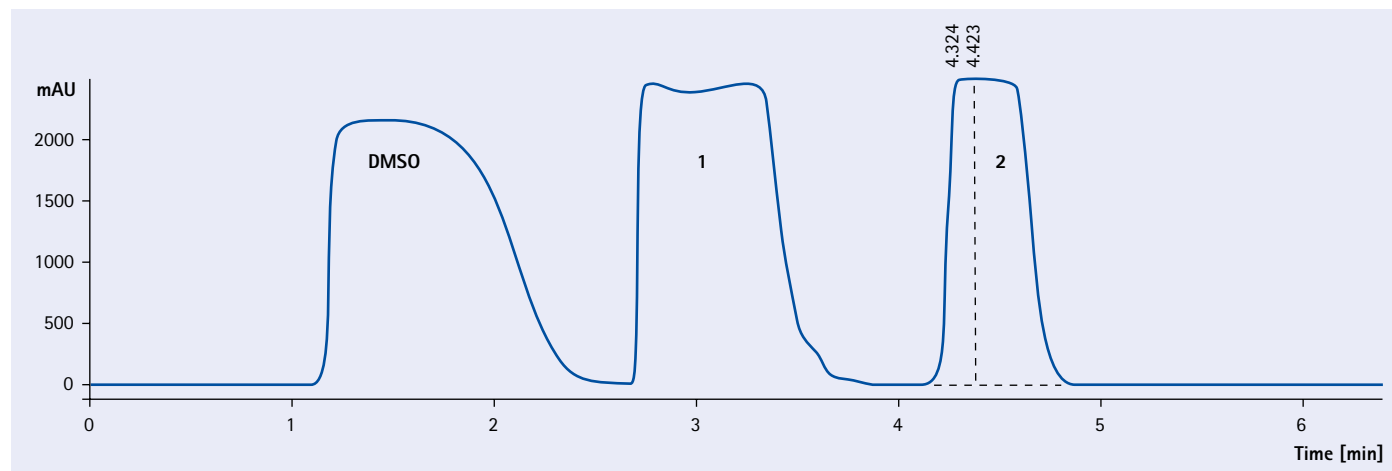

By courtesy of Dr. A. Espada and C. Anta, Lilly Spain

Chromolith® Prep

Chromolith® – increase in speed, efficiency and productivity

Chromolith® Prep monolithic stationary phases are new ultra-pure silica phases. Their special properties are due to a bimodal pore structure. This structure is based on the new "sol-gel" technology and consists of macropores and mesopores.



Ready-to-use Chromolith® Prep column

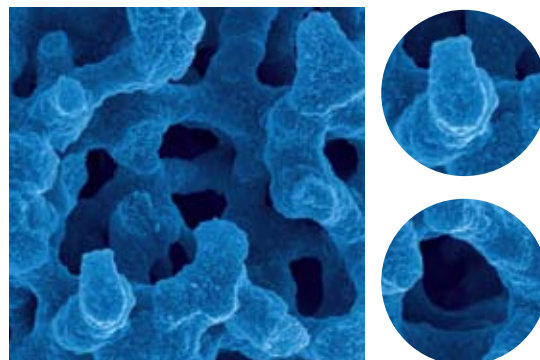

Mesopores and macropores of Chromolith® Prep Si

The combination of macro- and mesopores ensures high efficiency as well as high speed. The mesopores with an average diameter of 12 nm form the fine porous structure of the column interior and create a very large surface area on which adsorption of the target compounds occurs. The large macropores with a pore diameter of 3 µm form a dense network of pores and allow a high flow rate due to a low resistance factor. The resulting excellent accessibility of the mesopores (total porosity > 80%) ensures fast adsorption and desorption kinetics due to short diffusion length inside the pores. This results in dramatically reduced separation times providing an essential increase in productivity.

Typical technical data of Chromolith® Prep Si and RP-18e

Macropore size	3 µm
Mesopore size	12 nm (120 Å)
Specific pore volume	1 mL/g
Specific surface area	350 m ² /g
Packing density	0.2 g/mL
Total porosity	0.8
Surface pH	neutral
Dimension	100–25 mm
Maximum operating pressure	100 bar (1450 psi)

► Chromolith® RP-18 endcapped Chromolith® RP-18 endcapped columns are the fastest C18 columns in the world.
page 172

► Chromolith® Si
page 190

Customer benefits

- Low pressure drop at higher flow rate.
- The higher porosity assures fast adsorption and desorption kinetics.
- In comparison to particulate sorbents, monolithic column ensure shorter separation times which lead to less solvent consumption and shorter separation.
- Higher productivity and greater efficiency compared to particulate sorbents.

Ordering information – Chromolith® Prep Si 100–25 mm and RP–18e 100–25 mm

Product	Ordering No.	Dimension length	Dimension diameter	Contents of one package
Chromolith® Prep Si 100-25 mm	1.25251.0001	100 mm	25 mm	1 piece 2 connectors (1/8" and 1/16")
Chromolith® Prep RP-18e 100-25 mm	1.25252.0001	100 mm	25 mm	1 piece 2 connectors (1/8" and 1/16")
Chromolith® Prep guard cartridge Si 10-25 mm	1.25260.0001	10 mm	25 mm	1 piece
Chromolith® Prep guard cartridge RP-18e 10-25 mm	1.25261.0001	10 mm	25 mm	1 piece

The monolith is clad with a polymeric material (PEEK) and can be connected directly to each HPLC system and used as "ready to use" column.

Ordering information – Chromolith® Prep accessories

Product	Ordering No.	Dimension diameter	Contents of one package
Chromolith® Prep sealing set	1.25254.0001	25 mm	2 O-rings
Chromolith® Prep tool set	1.25255.0001	25 mm	1 mounting tool filter 1 mounting tool 1 hook wrench
Chromolith® Prep end cap set	1.25256.0001	25 mm	1 inlet cap complete 1 outlet cap
Chromolith® Prep frit set	1.25257.0001	25 mm	10 frits
Chromolith® Prep 25 mm guard cartridge holder	1.25258.0001	25 mm	1 piece
Chromolith® Prep 25 mm column coupler	1.25259.0001	25 mm	1 piece

The formula for direct scale-up

An analytical separation can be simply transferred to semi-preparative and preparative columns by linear transfer of methods. The objective of any preparative separation strategy is high sample throughput per unit of time. Therefore, columns are often run under concentration and/or volume overload conditions. The maximum load on the column however, is dependent on the complexity of the separation problem and the nature of the sample.

If working in the linear or the non-linear mode the calculation of the flow rate or injection volume is made according to the equation.

$$\frac{X_{\text{an}}}{\pi r_{\text{an}}^2} = \frac{X_{\text{pr}}}{\pi r_{\text{pr}}^2} \cdot \frac{1}{c_L}$$

X_{an}	Flow rate in the analytical system	
X_{pr}	Flow rate in the preparative system	$X_{\text{pr}} = X_{\text{an}} \cdot r_{\text{pr}}^2 \cdot c_L / r_{\text{an}}^2$
r_{an}	Radius of analytical column	
r_{pr}	Radius of preparative column	
c_L	Length of the preparative column to length of the analytical column	
M	Substance mass	$M_{\text{pr}} = M_{\text{an}} \cdot r_{\text{pr}}^2 \cdot c_L / r_{\text{an}}^2$

Guide values of typical flow rates and loading capacity for the transfer from an analytical to a preparative column

Columns	Column dimension [length/diameter]	Typical flow rate	Loading capacity	Loading volume
Analytical column	100 - 4.6 mm	2 mL/min	5 mg	5 - 50 µL
Preparative column	100 - 25 mm	60 mL/min	150 - 370 mg	100 - 1500 µL

Analytical separation

Chromolith® Performance RP-18e 100-4.6 mm

Column	Chromolith® Performance RP-18e 100-4.6 mm
Mobile phase	A: Water + 0.1% formic acid B: Acetonitrile
Gradient	linear gradient from 10% B to 40% in 14 min
Flow rate	2 mL/min
Detection	UV 254 nm
Sample	0.28 mg Heterocyclic racemate (EMD 53986) in 10 µL DMSO

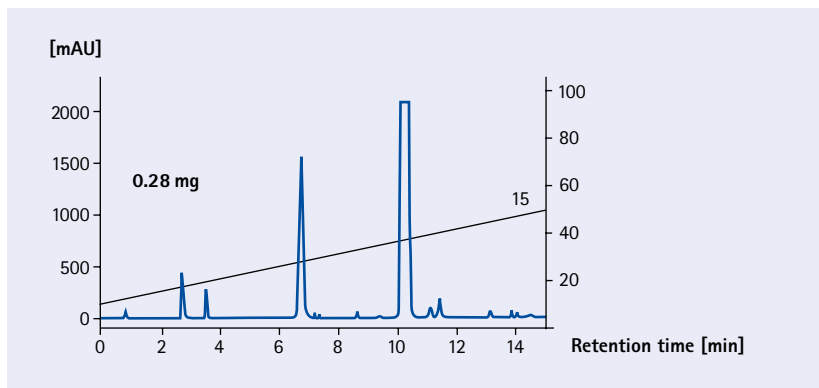

Preparative separation

Chromolith® Prep RP-18e 100-25 mm

Column	Chromolith® Prep RP-18e 100-25 mm
Mobile phase	A: Water + 0.1% formic acid B: Acetonitrile
Gradient	linear gradient from 10% B to 40% in 14 min
Flow rate	60 mL/min
Detection	UV 254 nm
Sample	8.46 mg Heterocyclic racemate (EMD 53986) in 300 µL DMSO

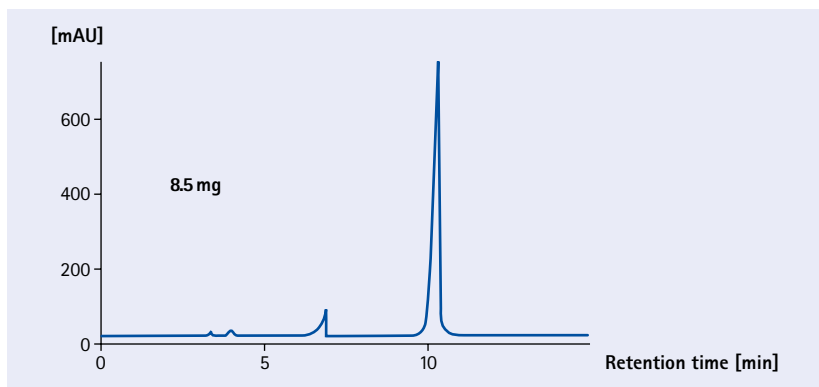

Chromolith® Prep RP-18e 100-25 mm

Column	Chromolith® Prep RP-18e 100-25 mm
Mobile phase	A: Water + 0.1% formic acid B: Acetonitrile
Gradient	linear gradient from 10% B to 40% in 14 min
Flow rate	60 mL/min
Detection	UV 254 nm
Sample	141 mg Heterocyclic racemate (EMD 53986) in 300 µL DMSO

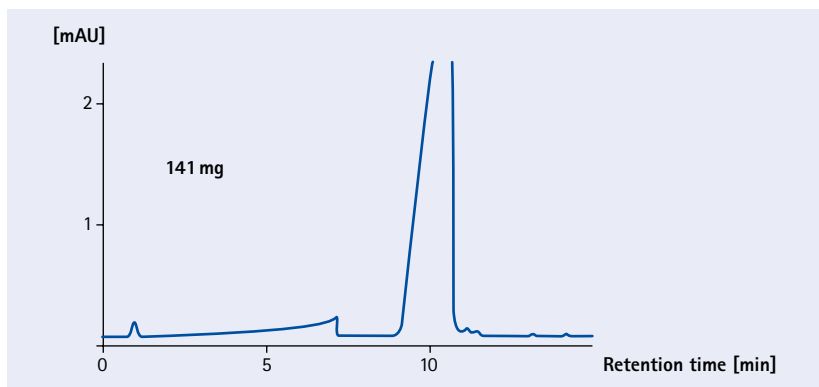

Various applications with Chromolith® Prep monolithic columns – comparison of flow rates

Chromolith® Prep columns can be operated with a flow rate of up to 400 mL/min and pressures of up to 100 bar. This is a tenfold increase of flow rate compared to equivalent size particulate packed columns.

Separation at different flow rates 40 and 390 mL/min Chromolith® Prep Si 100–25 mm

Column	Chromolith® Prep Si 100-25 mm
Solvent	n-Heptane / Dioxane (80/20 v/v)
Flow rate	40 mL/min
Sample	1. Toluene 2. Dimethylphthalate 3. Dibutylphthalate

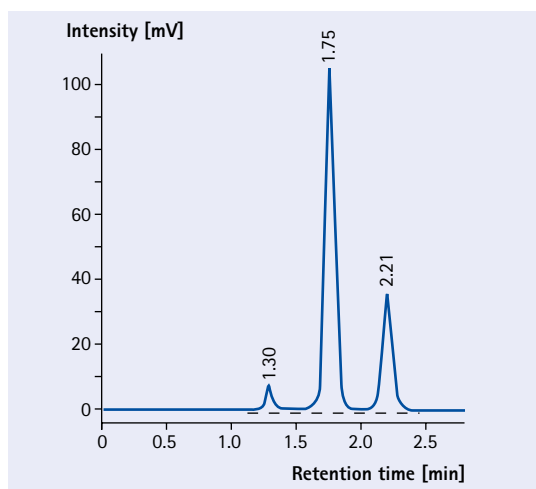

Chromolith® Prep Si 100–25 mm

Column	Chromolith® Prep Si 100-25 mm
Solvent	n-Heptane / Dioxane (80/20 v/v)
Flow rate	390 mL/min
Sample	1. Toluene 2. Dimethylphthalate 3. Dibutylphthalate

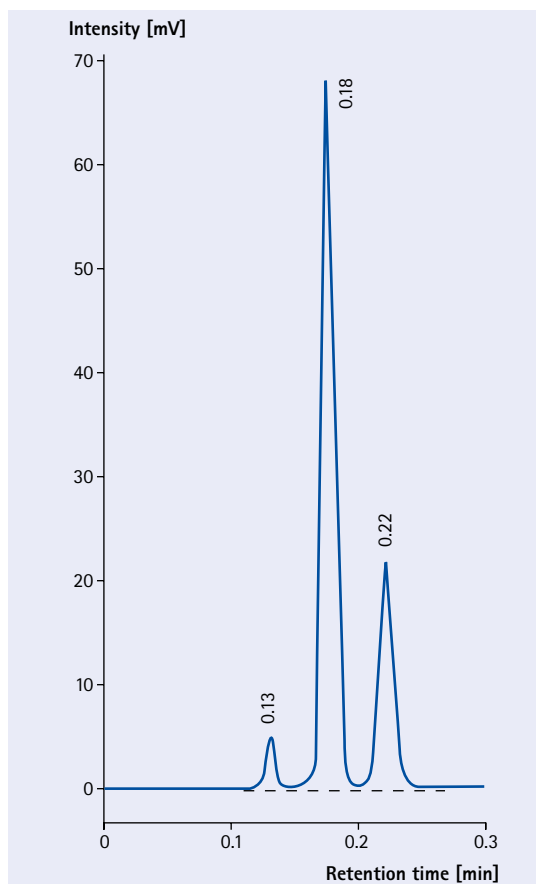

Separation of α - and δ -Tocopherol from sunflower oil at different flow rates

Flow rate 40 mL/min

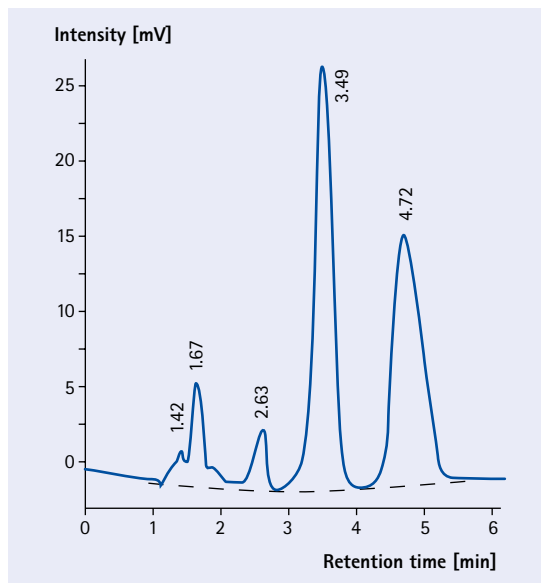

Flow rate 160 mL/min

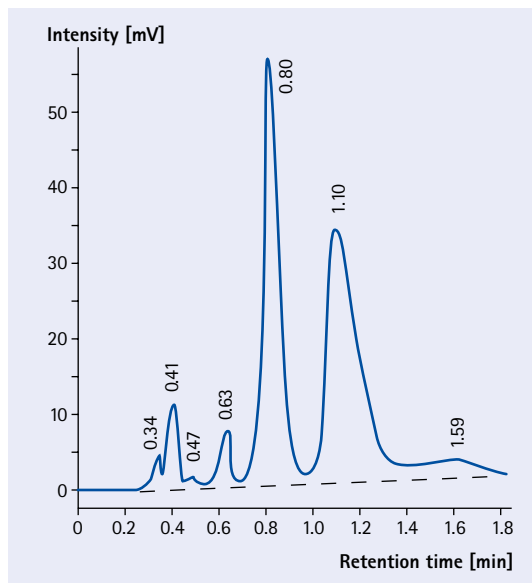

Separation of diastereomers with a productivity of 861 g/d

Chromolith® Prep Si 100–25 mm

Column	Chromolith® Prep Si 100–25 mm
Solvent	n-Heptane / Dioxane (80/20 v/v)
Flow rate	140 mL/min
Injection	249 mg
Cycle time	25 sec
Sample	Fluoro-dihydro-oxyranil-benzopyran

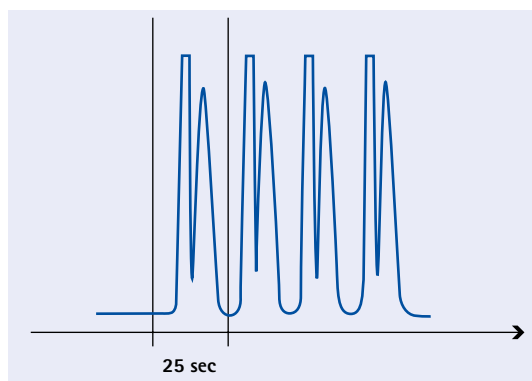

Preparative RP-Chromatography with monolithic columns

The selectivity of a Chromolith® Prep RP-18 endcapped column is comparable to common RP-18 endcapped reversed phase columns. It provides you with an excellent tool to solve your separation problems regarding nonpolar basic and acidic compounds as well as peptides. In most cases your existing methods from using particulate columns can easily be transferred to Chromolith® Prep. However for some applications it is worth optimizing the method to make use of the full potential of this enhanced technology.

Chromolith® Prep RP-18 endcapped 100–25 opens the door to high speed separation in preparative chromatography

Comparison of Chromolith® Prep RP-18 endcapped 100–25 mm with particulate material – separation of Oxime-derivates

The comparison of Chromolith® Prep RP-18 endcapped with a particulate Purospher® RP-18 endcapped-column (250–50 mm) shows that both separations have a similar resolution under the same chromatographic conditions, however Chromolith® Prep RP-18 endcapped has a better selectivity than Purospher® RP-18 endcapped as exhibited by the resolution of the additional isomer peak at 7 minutes.

Packing stand NW 50 (250–50) filled with Purospher® RP-18 endcapped, 10 µm

Column	Packing stand NW 50 (250–50) filled with Purospher® RP-18 endcapped, 10 µm
Mobile phase	A: Water + 0.05% TFA B: Acetonitrile + 0.05% TFA
Gradient	linear in 30 min up to 100% B
Flow rate	100 mL/min
Detection	UV 210 nm
Sample	125 mg Oxime-derivates in 500 µL Acetonitrile

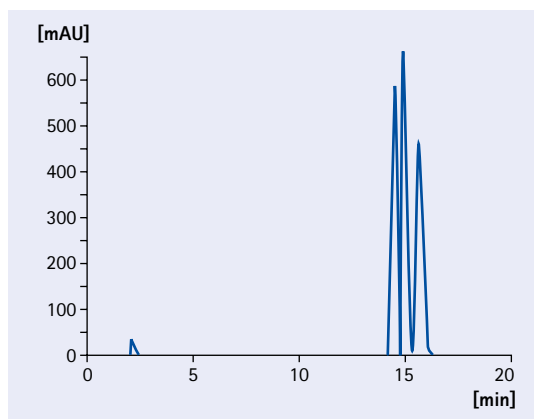

Chromolith® Prep RP-18 endcapped 100–25 mm

Column	Chromolith® Prep RP-18 endcapped 100–25 mm
Mobile phase	A: Water + 0.05% TFA B: Acetonitrile + 0.05% TFA
Gradient	linear in 11 min up to 100% B
Flow rate	100 mL/min
Detection	UV 210 nm
Sample	125 mg Oxime-derivates in 500 µL Acetonitrile

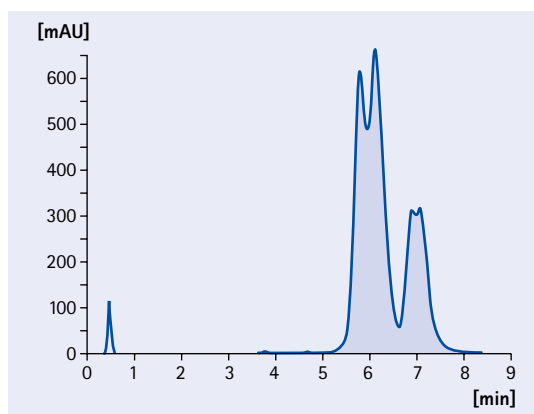

Separation of Hirudin (filtrate of crude extract)

Without any sample preparation the crude sample was injected directly onto the Chromolith® Prep RP-18 endcapped. The separation took only 5 minutes. It was possible to isolate the desired product from the impurities.

Chromolith® Prep RP-18 endcapped 100–25 mm

Column	Chromolith® Prep RP-18 endcapped 100–25 mm		
Mobile phase	A: Water + 0.1% Formic acid B: Acetonitrile 100%		
Gradient	Time [min]	% A	% B
	0	90	10
	10	70	30
	10.1	90	10
Flow rate	60 mL/min		
Detection	UV 254 nm		
Sample	23 mg Hirudin (filtrate of crude extract) in 5 mL solution injected		

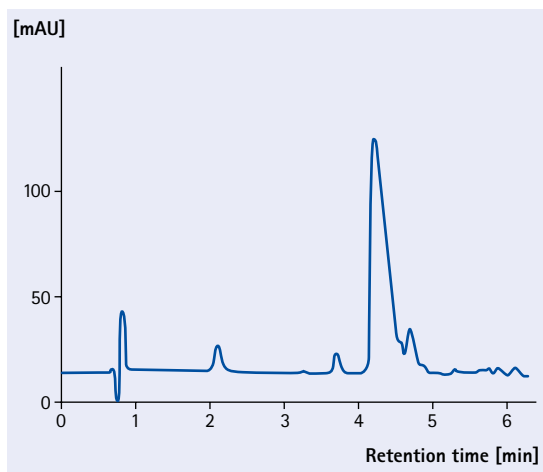

Separation of Dihydropyridines (Nifedipine, Nimodipine and Nisoldipine)

With monolithic silica rod technology it is possible to speed up your separation significantly!

Chromolith® Prep RP-18 endcapped shows a significant reduction of back-pressure.

Chromolith® Prep RP-18 endcapped 100–25 mm

Column	Chromolith® Prep RP-18 endcapped 100–25 mm		
Mobile phase	A: Water B: Acetonitrile		
Gradient	Time [min]	% A	% B
	0	80	20
	8	20	80
	8.1	80	20
Flow rate	100 mL/min		
Detection	UV 224 nm		
Sample	90 mg mixture of Nifedipine, Nimodipine and Nisoldipine		

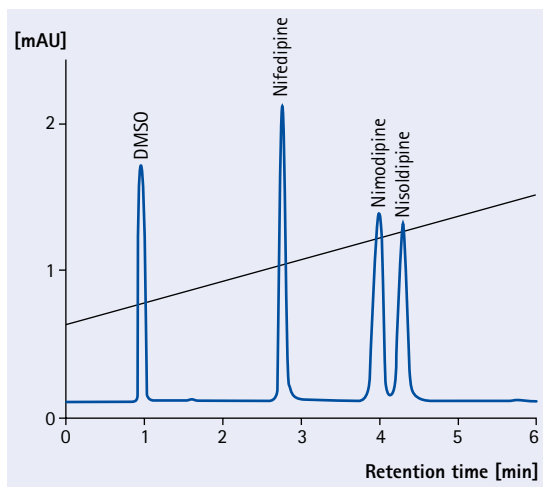

Purospher®

The all-around high performance solution for complex HPLC separations

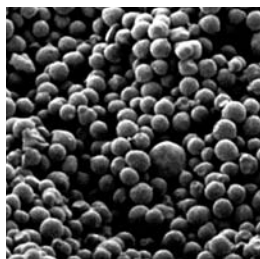

High-purity HPLC columns

The key component for modern RP-HPLC sorbents is a high purity silica as starting material. Purospher® HPLC columns are based on high purity, metal-free silica for outstanding separations with excellent peak symmetry. The base silica for Purospher® high purity HPLC columns is made from tetraalkoxysilane in sol-gel process. Due to the absence of metals in the silica matrix and combined with an optimized surface coating and shielding process, Purospher® columns provide tailing-free separations of acidic, basic, and chelating compounds. This is of particular advantage for any kind of method development in Research and Development (R&D) and Quality Control (QC) laboratories.

▶ Purospher® STAR RP-18 endcapped

The versatility you need!
page 219

▶ Purospher® STAR RP-8 endcapped

Optimized for more polar compounds
page 236

▶ Purospher® STAR Si (Silica) and NH₂ (Amino-phase)

page 238

▶ Purospher® RP-18 endcapped

Excellent peak symmetry with either basic or strongly acidic compounds
page 240

▶ Purospher® RP-18

Accelerate and simplify method development for basic compounds
page 242

▶ Customized packings

Always the right column
page 292

Accessories for particulate HPLC columns:

▶ manu-CART® cartridge holder for LiChroCART® cartridges

page 296

▶ LiChroCART® cartridge

Different lengths, different internal diameter
page 299

Purospher® HPLC columns benefits

- Enhanced performance and excellent peak symmetry due to high purity silica gel
- Outstanding batch-to-batch reproducibility for reliable analyses
- Balanced chromatographic properties (Tanaka Hexagon)
- Excellent separation efficiency for reliable results
- Extended column lifetime for higher laboratory efficiency

The Purospher® product family comprises different Purospher® HPLC packing materials

Purospher® RP-18 is polar endcapped and suitable for separations of strong basic or chelating compounds (no acidic compounds) and separations of hydrophilic compounds with a high percentage of water in the mobile phase.

Purospher® RP-18 endcapped is suitable for separations of complex samples with simple eluents.

Purospher® RP-18 HC is not endcapped with very good suitability for separation of polar, not basic compounds e.g. explosives.

Purospher® STAR RP-18 endcapped allows the tailing-free separation of neutral, acidic, basic or chelating compounds. The excellent stability up to pH 10.5 enables the separation of strong basic compounds with alkaline eluents. Purospher® STAR RP-18 endcapped is available in different particle sizes of 2 µm, 3 µm and 5 µm and as special UHPLC columns.

Purospher® STAR RP-8 endcapped for separation of polar compounds or separation of position isomeric compounds

Purospher® STAR NH₂ and Si for normal phase chromatography (Si) and separation of carbohydrates (NH₂)

Specifications of Purospher® high-purity HPLC columns

	Particle size [µm]	Pore size [Å]	Pore vol. [mL/g]	Spec. surface area [m ² /g]	% C load	Endcapping	pH stability	USP classification	Analytes
Purospher® STAR RP-18 endcapped	2, 3 or 5	120	1.1	330	17	hydrophobic	1.5 - 10.5	L1	neutral, acidic, basic or chelating compounds, pH stability
Purospher® STAR RP-8 endcapped	2, 3 or 5	120	1.1	330	11.2	hydrophobic	1.5 - 10.5	L7	polar compounds, position isomers
Purospher® STAR Si	5	120	1.1	330	-	no endcapping	2 - 7.5	L3	normal phase chromatography
Purospher® STAR NH₂	5	120	1.1	330	3.5	-	2 - 7.5	L8	carbohydrates
Purospher® RP-18 endcapped	5	120	1.0	350	18.0	hydrophobic	2 - 8	L1	acids, basic or chelating compounds
Purospher® RP-18	5	90	0.95	500	18.5	amino endcapping	2 - 7.5	L1	strong bases or chelating compounds
Purospher® RP-18 HC	5	90	1.0	> 470	18.0	no endcapping	2 - 7.5	L1	explosives

High purity silica gel

The prerequisite for a modern RP-sorbent is a highly purified silica as a starting material. Purospher® RP-18 has a total heavy-metal content of 5 ppm. Thus no chelate complexes can be formed, as the symmetrical elution of 2,2' bipyridine shows – a very sensitive metal-complexing agent.

Chromatographic conditions

Mobile phase	Heptane/Dioxane (90/10, V/V)
Flow rate	1 mL/min
Detection	UV 254 nm
Temperature	30°C

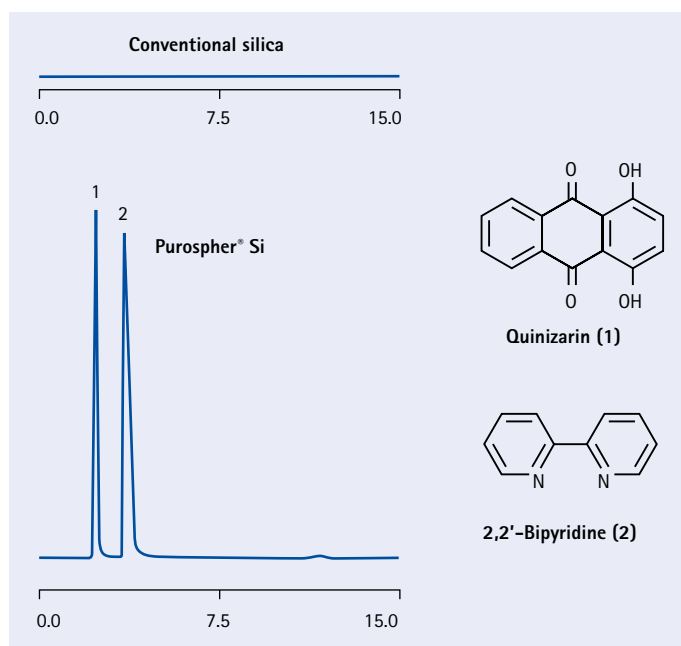

Characterization of Purospher® HPLC columns

Although it is very important to control the physical and chemical properties of stationary phases, a consistently high level of reproducibility can only be ensured by a comprehensive chromatographic characterization. **With respect to consistent selectivity we apply different approaches of leading scientists in HPLC.**

1. According to a proposal of Prof. Tanaka* Purospher® HPLC sorbents are characterized by a set of seven selected substances to describe retention capacity, hydrophobicity, steric selectivity and silanophilic properties.
2. The selectivity test of Prof. Engelhardt**, where the sorbent is controlled by injecting a mixture of 10 compounds.

Tanaka* test

The **Tanaka* test illustrates the overall chromatographic properties of stationary phases.** A set of seven selected substances is used to describe retention capacity, hydrophobicity, steric selectivity and silanophilic properties. To facilitate the illustration and to recognize the quality of a sorbent at one glance, the values of these parameters are outlined on the six axes of a hexagon. The more symmetrical the hexagon appears and the larger its area, the more balanced the stationary phase is in the sum of its chromatographic properties.

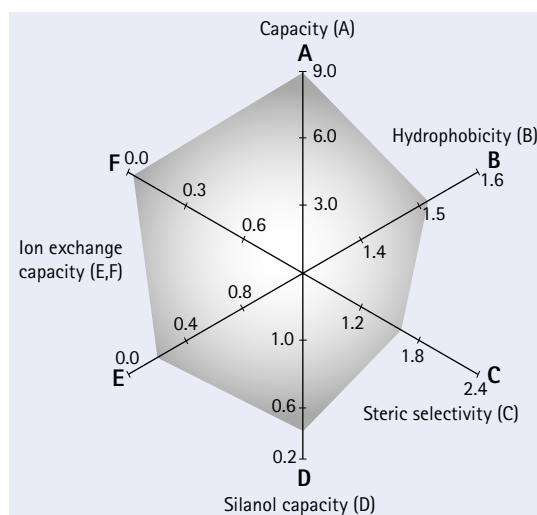

*Prof. Tanaka, *Kyoto Institute of Technology, J. Chrom. Sci.* 27, 725, 1989 | **Prof. Engelhardt, *Universität des Saarlandes, Saarbrücken, Chromatographia* 29, 59, 1990

Parameter for the characterization of Purospher® HPLC sorbents

Parameters	Property of the stationary phase	Factors in preparation of the stationary phase
(A) Retention capacity	k' (Pentylbenzene) / 80% Methanol	amount of alkyl chains silica surface coverage
(B) Hydrophobicity	k' (Pentylbenzene) / k' (Butylbenzene) / 80% Methanol	hydrophobic capacity surface coverage
(C) Steric selectivity	k' (Triphenylene) / k' (o-Terphenyl) / 80% Methanol	steric selectivity silane functionality surface coverage
(D) Silanol capacity	k' (Caffeine) / k' (Phenol) / 30% Methanol	silanol capacity residual silanols endcapping surface coverage
(E) Ion exchange capacity	k' (Benzylamine) / k' (Phenol) / 30% Methanol / 70% Phosphate buffer pH 7.6	ion exchange capacity at pH 7 residual silanols active sites pH 7
(F) Ion exchange capacity	k' (Benzylamine) / k' (Phenol) / 30% Methanol / 70% Phosphate buffer pH 2.7	ion exchange capacity at pH 3 active sites pH 3 treatment of basic silica

Tanaka test 1–4

Tanaka 1

[Retention capacity/Hydrophobicity/Steric Selectivity]

Column	LiChroCART® 150-4.6 Purospher® STAR RP-18 endcapped, 5 µm
Mobile phase	Methanol / Water 80:20
Flow rate	1.0 mL/min
Detection	UV 254 nm
Temperature	30°C
Injection volume	10 µL
Sample	1. Uracil 2. Butylbenzene 3. o-Terphenyl 4. Pentylbenzene 5. Triphenylene

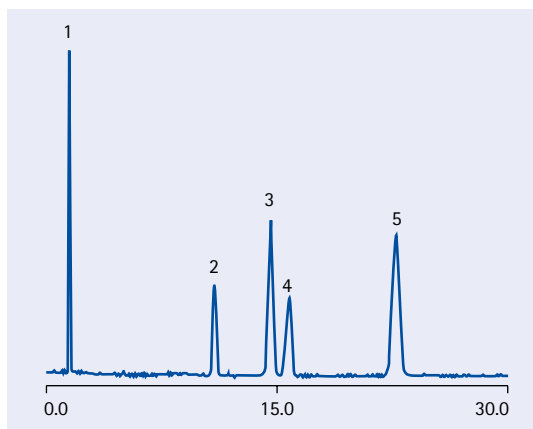

Tanaka 2 [Silanophilic properties]

Column	LiChroCART® 125-4 Purospher® STAR RP-18 e, 5 µm
Mobile phase	A: Methanol / Water 30:70 (v/v) B: Acetonitrile / Water 30:70 (v/v)
Flow rate	1.0 mL/min
Detection	UV 254 nm
Sample	A: 1. Uracil 2. Caffeine 3. Phenol B: 1. Pyridine 2. Phenol

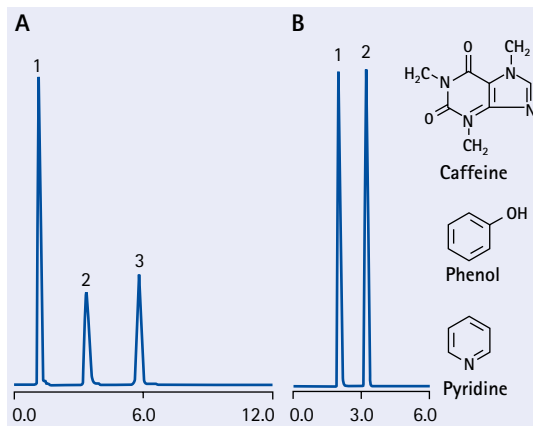

Tanaka 3+4 [Ion exchange properties]

Column	LiChroCART® 125-4 Purospher® STAR RP-18 endcapped, 5 µm
Mobile phase	Methanol (0.02 M) / Phosphoric acid 30:70 (v/v)
Flow rate	0.6 mL/min
Detection	UV 254 nm
Sample	1. Uracil 2. Benzylamine 3. Phenol

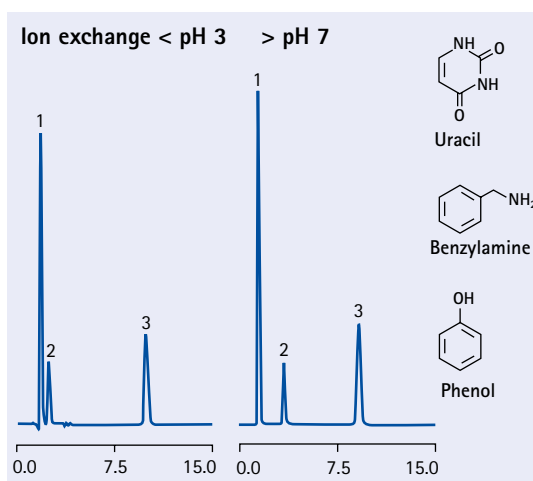

Engelhardt* test

This test, developed by Prof. Engelhardt, is suitable for describing the properties of an RP-phase. Toluene and ethylbenzene demonstrate the hydrophobic properties; neutral polar interactions can be investigated using phenol and ethyl benzoate. The important behavioural characteristic with respect to basic compounds is shown by the injection of 5 different amines. Aniline is eluted before phenol and with excellent peak shape. **The most important criteria is the coelution of the isomers of ethylaniline, that indicates a good suppression of the silanolic activity.**

* Prof. Engelhardt, Universität des Saarlandes, Saarbrücken, Chromatographia 29, 59, 1990

Purospher® RP-18

Purospher® RP-18 shows no co-elution of p-, m- and o-ethyl aniline and polar interactions due to the amino endcapping of this phase. The anilines are eluting with symmetric peaks, which shows its very good suitability for separation of strong bases.

Column	LiChroCART® 125-4 Purospher® RP-18	
Mobile phase	Methanol/Water 55/45 (v/v)	
Flow rate	1.0 mL/min	
Detection	UV 254 nm	
Temperature	ambient	
Sample	1. Thiourea	t_0
	2. Aniline	basic
	3. Phenol	acidic
	4. p-, m-, o-ethylaniline	basic
	5. N,N-Dimethylaniline	basic
	6. Ethyl benzoate	neutral
	7. Toluene	neutral
	8. Ethylbenzene	neutral

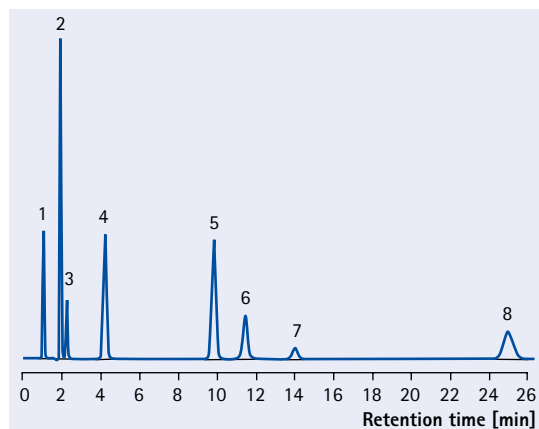

Purospher® RP-18 endcapped

Purospher® RP-18 endcapped shows perfect co-elution of p-, m- and o-ethyl aniline indicating no polar interactions. The anilines are eluting as symmetric peaks which shows the very good suitability for separation of strong bases. The retention time of ethyl benzene indicates the hydrophobic properties of the phase.

Column	LiChroCART® 125-4 Purospher® RP-18 endcapped	
Mobile phase	Methanol/Water 55/45 (v/v)	
Flow rate	1.0 mL/min	
Detection	UV 254 nm	
Temperature	ambient	
Sample	1. Thiourea	t_0
	2. Aniline	basic
	3. Phenol	acidic
	4. p-, m-, o-ethylaniline	basic
	5. N,N-Dimethylaniline	basic
	6. Ethyl benzoate	neutral
	7. Toluene	neutral
	8. Ethylbenzene	neutral

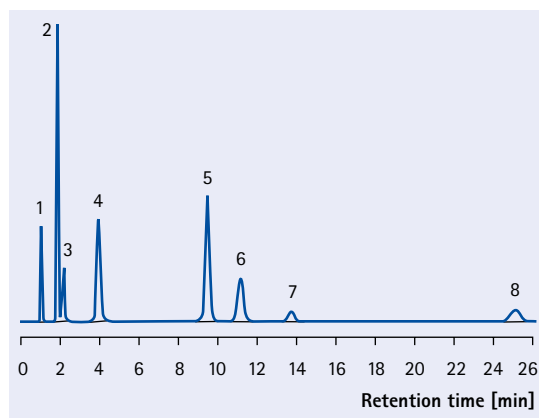

Purospher® STAR RP-18 endcapped

Purospher® STAR RP-18 endcapped shows perfect co-elution of p-, m- and o-ethyl aniline indicating no polar interactions. The anilines are eluting as symmetric peaks, which shows the very good suitability for separation of strong bases. Purospher® STAR RP-18 endcapped shows an analogue selectivity to Purospher® RP-18 endcapped.

Column	LiChroCART® 125-4 Purospher® STAR RP-18 endcapped	
Mobile phase	Methanol/Water 55/45 (v/v)	
Flow rate	1.0 mL/min	
Detection	UV 254 nm	
Temperature	ambient	
Sample	1. Thiourea	t_0
	2. Aniline	basic
	3. Phenol	acidic
	4. p-, m-, o-ethyl aniline	basic
	5. N,N-Dimethylaniline	basic
	6. Ethyl benzoate	neutral
	7. Toluene	neutral
	8. Ethylbenzene	neutral

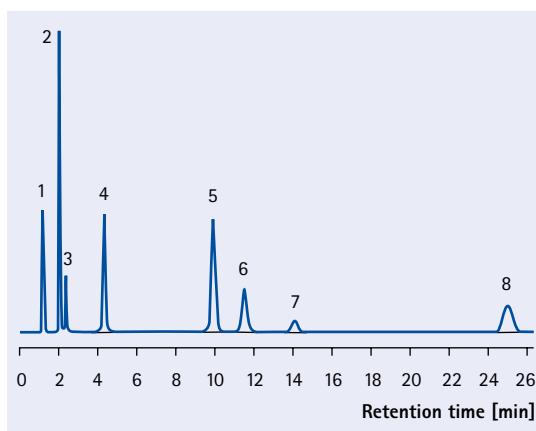
**Purospher® RP-18 HC**

Purospher® RP-18 HC shows very clear polar interactions, due to no endcapping. Aniline and Phenol are eluting in one peak. Bases are eluting late. Best suitability for separation of polar, not basic molecules e.g. explosives.

Column	LiChroCART® 125-4 Purospher® RP-18 HC	
Mobile phase	Methanol/Water 55/45 (v/v)	
Flow rate	1.0 mL/min	
Detection	UV 254 nm	
Temperature	ambient	
Sample	1. Thiourea	t_0
	2. Aniline	basic
	3. Phenol	acidic
	4. p-, m-, o-ethyl aniline	basic
	5. N,N-Dimethylaniline	basic
	6. Ethyl benzoate	neutral
	7. Toluene	neutral
	8. Ethylbenzene	neutral

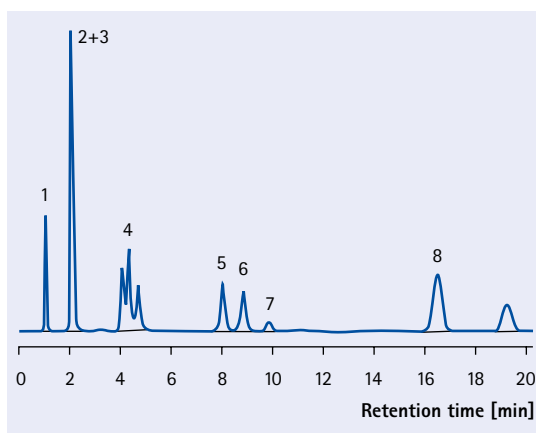

Purospher® STAR RP-8 endcapped

Purospher® STAR RP-8 endcapped shows no co-elution of p-, m- and o-ethyl aniline and polar interactions, because of the thin hydrophobic coverage with short C-chains. The anilines are eluting as symmetric peaks, which shows the very good suitability for separation of strong bases. Ethyl benzoate and toluene are eluting in one peak – this is typical for C-8 phases.

Column	LiChroCART® 125-4 Purospher® STAR RP-8 endcapped	
Mobile phase	Methanol/Water 55/45 (v/v)	
Flow rate	1.0 mL/min	
Detection	UV 254 nm	
Temperature	ambient	
Sample	1. Thiourea	t_0
	2. Aniline	basic
	3. Phenol	acidic
	4. p-, m-, o-ethylaniline	basic
	5. N,N-Dimethylaniline	basic
	6. Ethyl benzoate	neutral
	7. Toluene	neutral
	8. Ethylbenzene	neutral

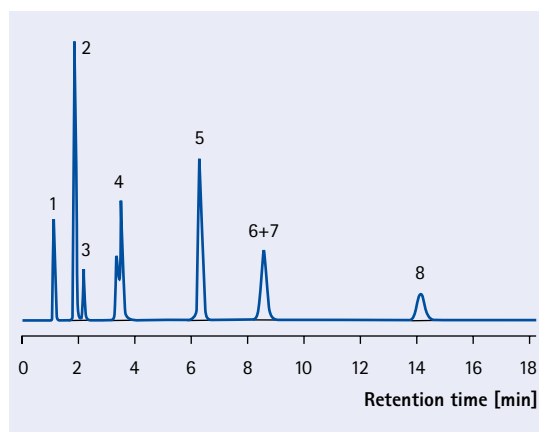

Chromatographic properties of Purospher® stationary phases

	Peak symmetry of complexing agents	Polar interactions	Steric selectivity	CH ₂ group selectivity	Silanol group activity	Hydrophobicity
Purospher® RP-18	+++	++	+++	+++	++	+
Purospher® RP-18 endcapped	+++	-	+++	+++	-	+++
Purospher® STAR RP-18 endcapped	+++	-	+++	+++	-	+++
Purospher® STAR RP-8 endcapped	+++	+	+	++	++	+
Purospher® RP-18 HC	+++	++	+++	+++	+	++

Purospher® STAR RP-18 endcapped

The versatility you need!

Purospher® STAR RP-18 endcapped HPLC columns are designed for universal use. Basic, neutral, and metal chelating compounds can easily be separated with simple mobile phases – naturally without peak tailing! Thanks to its outstanding performance and stability, Purospher® STAR RP-18 endcapped offers maximum flexibility in method development. Robust methods can be developed over the entire pH range from 1.5 to 10.5. The high pH-stability up to pH 10.5 allows the separation of strongly basic compounds with alkaline eluents. The combination of high purity silica, best all-round retention characteristics, outstanding pH stability up to pH 10.5, and suitability for up to 100% aqueous mobile phases, make Purospher® STAR RP-18 endcapped an all-round top performance column, almost universal in its range of applications.



Experience the performance of Purospher® STAR RP-18 endcapped

- Highest silica purity (99.999%) for excellent peak symmetry
- High separation efficiency
- Absolutely reproducible results from run-to-run and from batch-to-batch
- Best all-round performance according to Tanaka
- Outstanding pH-stability from pH 1.5 – 10.5
- No phase collapse when using highly aqueous mobile phases
- Good suitability for LC-MS applications

Key performance benefits: Fast method development of complex samples across the pH range from 1.5 to 10.5 at different mobile phases and temperature conditions.

Specification of Purospher® STAR RP-18 endcapped

Sorbent characteristics	High purity silica with polymeric C18 modification and endcapping	
Metal content	Na, Ca, Mg, Al: 1 ppm; Fe: 3 ppm	
Particle shape	spherical	
Particle size	2 µm, 3 µm and 5 µm	
Pore size	12 nm (120 Å)	
Pore volume	1.1 mL/g	
Specific surface area	330 m ² /g	
Carbon load	17% C	
Coverage of the surface	3 µmol/m ²	
Efficiency	5 µm	> 90,000 N/m
	3 µm	> 130,000 N/m
	2 µm	> 180,000 N/m
pH range	pH 1.5 – 10.5	
Shipping eluent	Acetonitrile/Water	

► Purospher® STAR UHPLC columns
page 210

► Purospher® STAR RP-8 endcapped Optimized for more polar compounds
page 212

► Purospher® STAR Si (Silica) and NH₂ (Amino-phase)
page 214

► Purospher® RP-18 endcapped Excellent peak symmetry with either basic or strongly acidic compounds
page 216

► Purospher® RP-18 Accelerate and simplify method development for basic compounds
page 218

► Customized packings Always the right column
page 268

Accessories for particulate HPLC columns:

► manu-CART® cartridge holder for LiChroCART® cartridges
page 272

► LiChroCART® cartridge Different lengths, different internal diameter
page 275

► Hibar® column
page 277

Ordering information – Purospher® STAR RP-18e, stainless steel cartridges LiChroCART®

Product	Ordering No.	Particle size	Dimension length	Dimension i.d.	Contents of one package
Purospher® STAR RP-18 endcapped cartridge set (1 LiChroCART® 30-2 and 1 manu-CART® 30 mm)	1.50237.0001	3 µm	30 mm	2 mm	1 set
Purospher® STAR RP-18 endcapped	1.50238.0001	3 µm	30 mm	2 mm	3 pieces
Purospher® STAR RP-18 endcapped cartridge set (1 LiChroCART® 55-2 and 1 manu-CART® 55 mm)	1.50240.0001	3 µm	55 mm	2 mm	1 set
Purospher® STAR RP-18 endcapped cartridge set	1.50241.0001	3 µm	55 mm	2 mm	3 pieces
Purospher® STAR RP-18 endcapped	1.50623.0001	5 µm	100 mm	2 mm	1 piece
Purospher® STAR RP-18 endcapped	1.50255.0001	5 µm	125 mm	2 mm	1 piece
Purospher® STAR RP-18 endcapped	1.50624.0001	5 µm	150 mm	2 mm	1 piece
Purospher® STAR RP-18 endcapped	1.50256.0001	5 µm	250 mm	2 mm	1 piece
Purospher® STAR RP-18 endcapped	1.50625.0001	5 µm	100 mm	3 mm	1 piece
Purospher® STAR RP-18 endcapped	1.50253.0001	5 µm	125 mm	3 mm	1 piece
Purospher® STAR RP-18 endcapped	1.50626.0001	5 µm	150 mm	3 mm	1 piece
Purospher® STAR RP-18 endcapped	1.50254.0001	5 µm	250 mm	3 mm	1 piece
Purospher® STAR RP-18 endcapped cartridge set (1 LiChroCART® 30-4 and 1 manu-CART® 30 mm)	1.50239.0001	3 µm	30 mm	4 mm	1 set
Purospher® STAR RP-18 endcapped	1.50225.0001	3 µm	30 mm	4 mm	3 pieces
Purospher® STAR RP-18 endcapped cartridge set (1 LiChroCART® 55-4 and 1 manu-CART® 55 mm)	1.50242.0001	3 µm	55 mm	4 mm	1 set
Purospher® STAR RP-18 endcapped	1.50231.0001	3 µm	55 mm	4 mm	3 pieces
Purospher® STAR RP-18 endcapped	1.51460.0001	3 µm	75 mm	4 mm	1 piece
Purospher® STAR RP-18 endcapped	1.50250.0001	5 µm	4 mm	4 mm	10 pieces
Purospher® STAR RP-18 endcapped	1.50251.0001	5 µm	125 mm	4 mm	1 piece
Purospher® STAR RP-18 endcapped	1.50252.0001	5 µm	250 mm	4 mm	1 piece
Purospher® STAR RP-18 endcapped	1.50627.0001	5 µm	100 mm	4.6 mm	1 piece
Purospher® STAR RP-18 endcapped	1.50358.0001	5 µm	150 mm	4.6 mm	1 piece
Purospher® STAR RP-18 endcapped	1.50359.0001	5 µm	250 mm	4.6 mm	1 piece
Purospher® STAR RP-18 endcapped	1.50257.0001	5 µm	250 mm	10 mm	1 piece

The LiChroCART® columns (75, 125, 150 and 250 mm length) in the list above (2, 3, 4 and 4.6 mm i.d.) require part number 1.51486.0001 manu-CART® cartridge column holder, which can be used to hold one cartridge column with or without a 4–4 mm guard column. LiChroCART® columns 250–10 mm require part number 1.51419.0001 manu-CART® 10. The short LiChroCART® columns (30 and 55 mm length) can be ordered as a set including the corresponding cartridge holder and one cartridge, or as a pack of 3 cartridges without cartridge holder. Additional dimensions available as customized packings see page 292.

The separate part numbers for the cartridge are as follows: 1.50227.0001 LiChroCART® cartridge holder for 30 mm cartridge and 1.50226.0001 LiChroCART® cartridge holder for 55 mm cartridge.

Ordering information – Purospher® STAR RP-18e, stainless steel Hibar® RT columns

Product	Ordering No.	Particle size	Dimension length	Dimension i.d.	Contents of one package
Purospher® STAR RP-18 endcapped	1.50393.0001	3 µm	50 mm	3 mm	1 piece
Purospher® STAR RP-18 endcapped	1.50398.0001	3 µm	100 mm	3 mm	1 piece
Purospher® STAR RP-18 endcapped	1.50413.0001	3 µm	125 mm	3 mm	1 piece
Purospher® STAR RP-18 endcapped	1.50414.0001	3 µm	150 mm	3 mm	1 piece
Purospher® STAR RP-18 endcapped	1.50427.0001	3 µm	250 mm	3 mm	1 piece
Purospher® STAR RP-18 endcapped	1.50428.0001	3 µm	50 mm	4 mm	1 piece
Purospher® STAR RP-18 endcapped	1.50431.0001	3 µm	125 mm	4 mm	1 piece
Purospher® STAR RP-18 endcapped	1.50468.0001	3 µm	250 mm	4 mm	1 piece
Purospher® STAR RP-18 endcapped	1.50469.0001	3 µm	100 mm	4.6 mm	1 piece
Purospher® STAR RP-18 endcapped	1.50470.0001	3 µm	150 mm	4.6 mm	1 piece
Purospher® STAR RP-18 endcapped	1.50471.0001	3 µm	250 mm	4.6 mm	1 piece
Purospher® STAR RP-18 endcapped	1.50593.0001	5 µm	50 mm	2 mm	1 piece
Purospher® STAR RP-18 endcapped	1.50595.0001	5 µm	100 mm	2 mm	1 piece
Purospher® STAR RP-18 endcapped	1.50596.0001	5 µm	125 mm	2 mm	1 piece
Purospher® STAR RP-18 endcapped	1.50597.0001	5 µm	150 mm	2 mm	1 piece
Purospher® STAR RP-18 endcapped	1.50598.0001	5 µm	250 mm	2 mm	1 piece
Purospher® STAR RP-18 endcapped	1.50607.0001	5 µm	50 mm	3 mm	1 piece
Purospher® STAR RP-18 endcapped	1.50612.0001	5 µm	100 mm	3 mm	1 piece
Purospher® STAR RP-18 endcapped	1.50615.0001	5 µm	125 mm	3 mm	1 piece
Purospher® STAR RP-18 endcapped	1.50617.0001	5 µm	150 mm	3 mm	1 piece
Purospher® STAR RP-18 endcapped	1.50620.0001	5 µm	250 mm	3 mm	1 piece
Purospher® STAR RP-18 endcapped	1.50621.0001	5 µm	50 mm	4 mm	1 piece
Purospher® STAR RP-18 endcapped	1.50036.0001	5 µm	125 mm	4 mm	1 piece
Purospher® STAR RP-18 endcapped	1.50037.0001	5 µm	250 mm	4 mm	1 piece
Purospher® STAR RP-18 endcapped	1.50622.0001	5 µm	100 mm	4.6 mm	1 piece
Purospher® STAR RP-18 endcapped	1.51455.0001	5 µm	150 mm	4.6 mm	1 piece
Purospher® STAR RP-18 endcapped	1.51456.0001	5 µm	250 mm	4.6 mm	1 piece

The Hibar® RT columns are complete with endfittings. When using a guard column with a Hibar® RT column, we recommend part number 1.51487.0001 guard column cartridge holder for 4–4 mm guard column cartridges LiChroCART®. Additional dimensions available as customized packings see page 292.



Purospher® STAR RP-18 endcapped column

Purospher® STAR RP-18 endcapped



Characterization of Purospher® STAR RP-18 endcapped

Purospher® STAR RP-18 endcapped HPLC columns are designed for universal use. It doesn't matter if your samples are basic, neutral, metal chelating or indeed any other format. You can be sure that Purospher® STAR can do it, naturally without peak tailing! This is proved by many users, who appreciate the excellent properties of Purospher® STAR RP-18 endcapped HPLC columns.

Surface modification of Purospher® STAR RP-18 endcapped

The polymeric surface modification of Purospher® RP-18 endcapped provides a nearly perfect coverage of the surface. This prevents polar interactions.

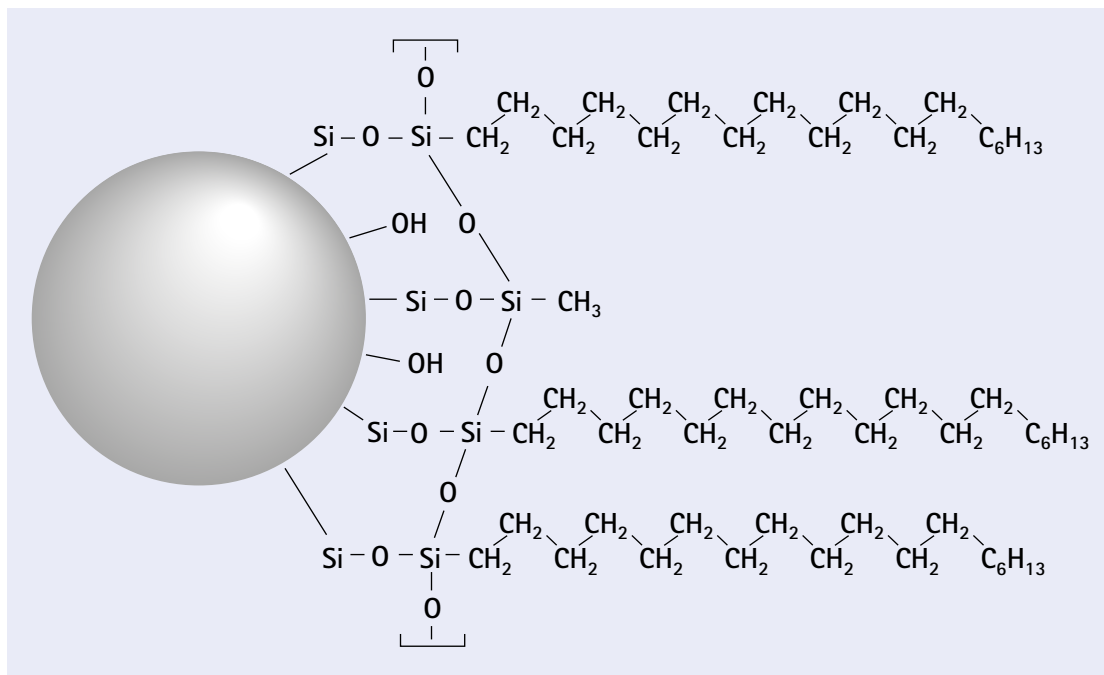

*Purospher® STAR RP-18
endcapped column*

Highest purity

Due to the absence of metals in the silica matrix, in combination with a complete coverage of the silica surface, this stationary phase enables tailing-free chromatography of acidic, basic and chelating compounds. There are differences in quality of so-called "high purity" HPLC column materials. The peak shape of the complexing agent Quinizarin is the best indicator for purity of silica.

The column comparison shown in the figures below demonstrates Purospher® STAR RP-18 endcapped with the best peak-symmetry for Quinizarin and the silica of highest purity.

Mobile phase	Methanol/Buffer pH 7.0 80/20 (5 mmol KH ₂ PO ₄ and 5 mmol K ₂ HPO ₄)
Flow rate	1.0 mL/min
Detection	UV 254 nm
Temperature	22°C
Sample	1. Uracil 2. Toluene 3. Ethylbenzene 4. Quinizarin 5. Amitriptyline

Purospher® STAR RP-18 endcapped

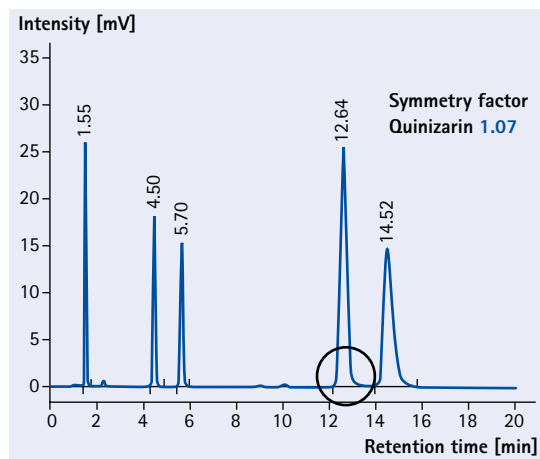

Column I

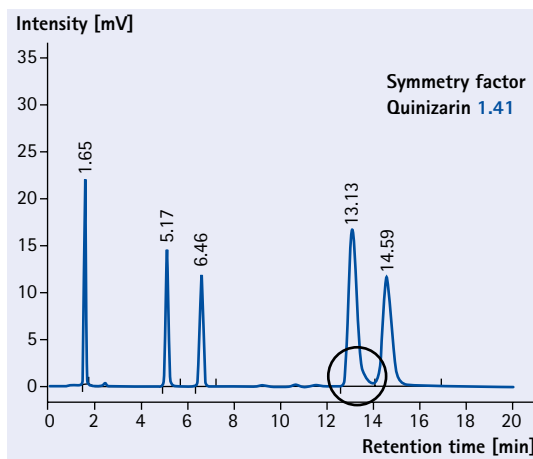

Column X

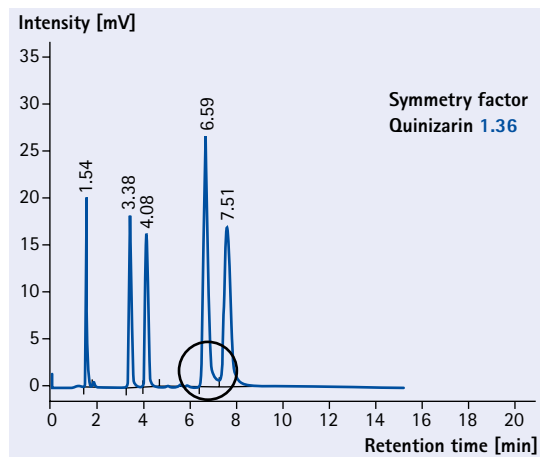

Column L

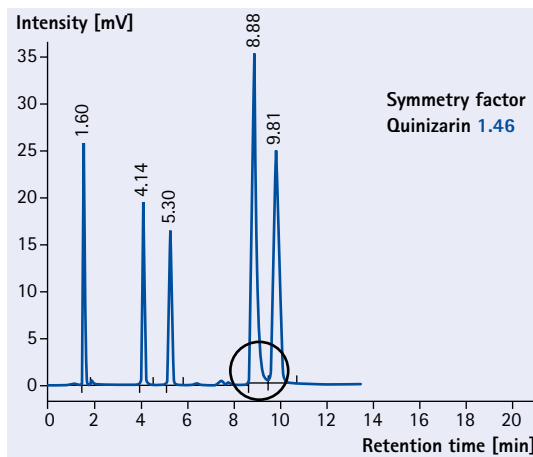

Outstanding pH-stability

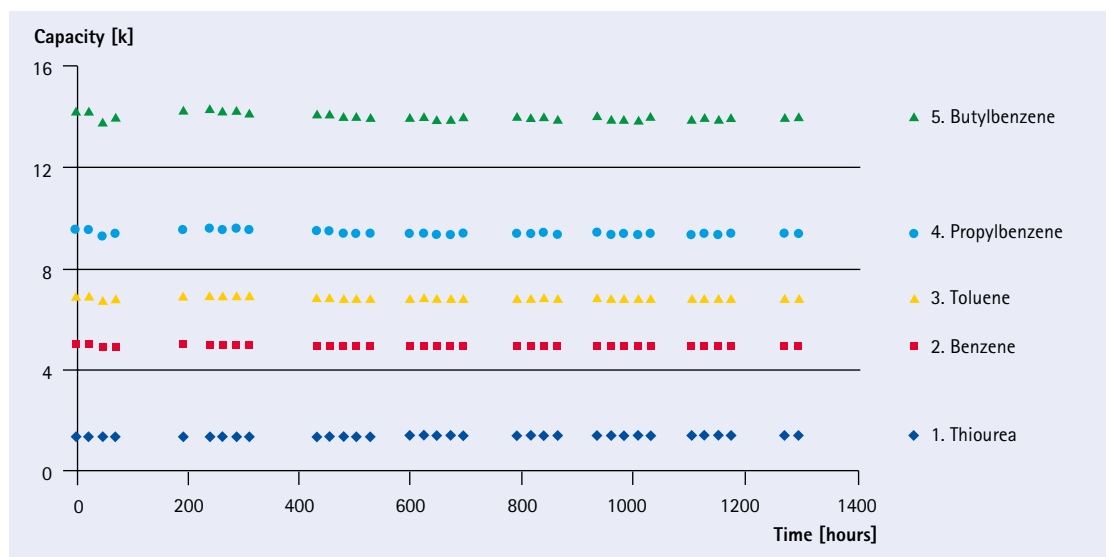

Stability test at pH 10.5

Column	LiChroCART® 150-4.6 Purospher® STAR RP-18 endcapped, 5 µm
Mobile phase	Acetonitrile/Water (0.1% NH ₃ ; [25%]; 60 : 40)
Flow rate	1.0 mL/min
Detection	UV 254 nm
Temperature	ambient
Injection volume	10 µL
Sample	1. Thiourea 2. Benzene 3. Toluene 4. Propylbenzene 5. Butylbenzene

A column that is robust, stable in a range of eluent conditions has an extended column life and provides the required pH stability for 99% of common analysis. Purospher® STAR RP-18 endcapped has outstanding pH stability. Various studies have shown that Purospher® STAR RP-18 endcapped remains stable and reproducible in a pH range of 1.5 to 10.5. This ensures a simple choice in most applications.

Excellently balanced

The Tanaka* test (please see page 214) is established world-wide as the best method of comparing the selectivity and performance of HPLC columns. This test summarizes and visualizes all the most important parameters required when choosing the right HPLC column and allows easy comparisons to be made.

A set of seven selected substances is used to describe capacity, hydrophobicity, steric selectivity and silanophilic properties. To facilitate the illustration and to recognize the quality of a sorbent at one glance, the values of these parameters are outlined on the six axes of a hexagon. **The more symmetrical the hexagon appears and the larger its area, the more balanced the stationary phase is in the sum of its chromatographic properties.**

*Prof. Tanaka, Kyoto Institute of Technology, *J. Chrom. Sci.* 27, 725, 1989

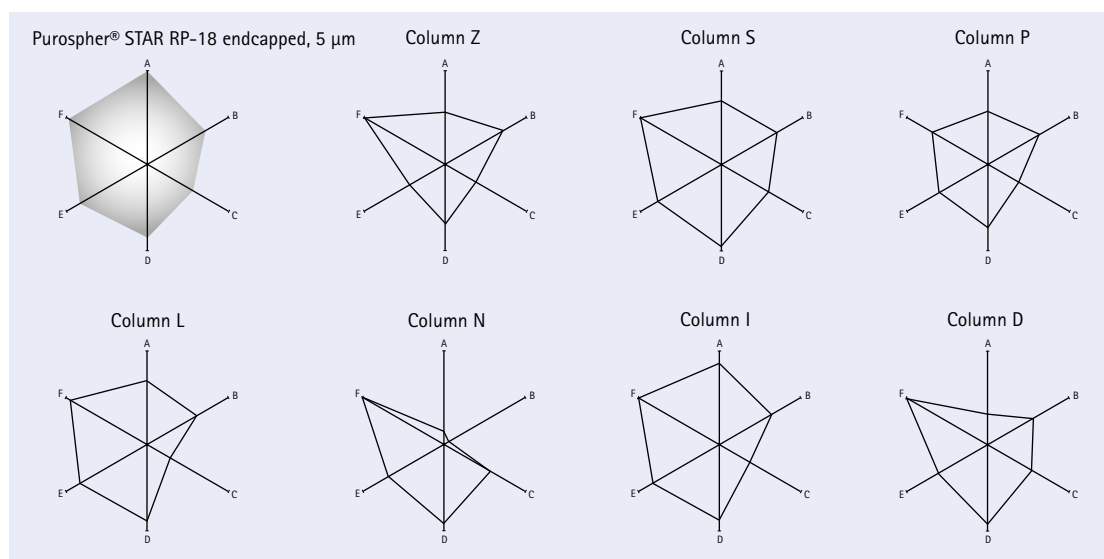

Tanaka test results for Purospher® STAR RP-18e

Column	Purospher® STAR RP-18 endcapped, 5 µm			
Chromatographic properties				
A	Retention capacity	K	Pentyl benzene	9.59
B	Hydrophobicity	α	Pentyl-/Butyl benzene	1.51
C	Steric selectivity	α	Triphenylene/o-Terphenyl	1.63
D	Silanol capacity	α	Caffeine/Phenol	0.44
E	Ion exchange capacity	α	Benzylamine/Phenol pH 7.6	0.23
F	Ion exchange capacity	α	Benzylamine/Phenol pH 2.7	0.02

Use with 100% aqueous phase

Standard reversed phase columns, particularly RP-18 columns, often suffer from phase collapse when used in combination with highly aqueous mobile phases. The outstanding performance of Purospher® STAR RP-18 endcapped enables the use with 100% aqueous mobile phases in combination with selectivity of a classical RP-18 stationary phase. **Experience the performance of Purospher® STAR RP-18 endcapped HPLC columns – the best choice.** Chromatogram **A** shows the first separation with 1% acetic acid as mobile phase. Chromatogram **B** shows the same separation after 3 hours.

Purospher® STAR RP-18 endcapped

Only Purospher® STAR RP-18 endcapped shows the same separation in Chromatogram B. In contrast to competitive columns Purospher® STAR RP-18 endcapped is suitable as aqua phase.

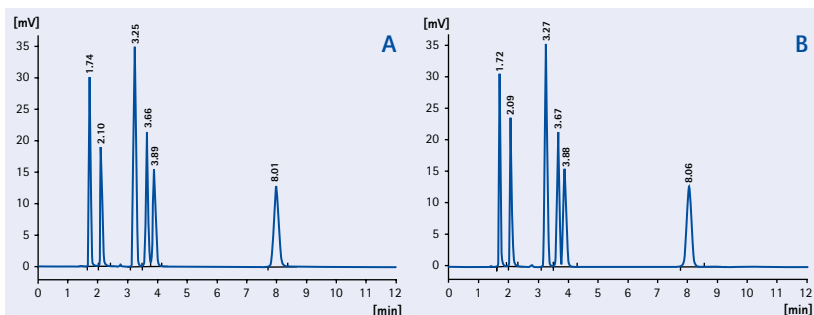

Column I

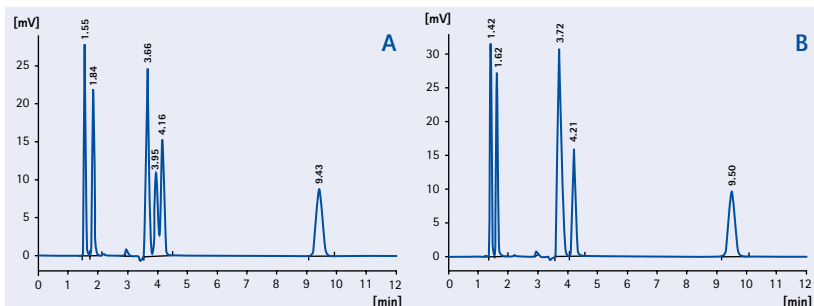

Column X

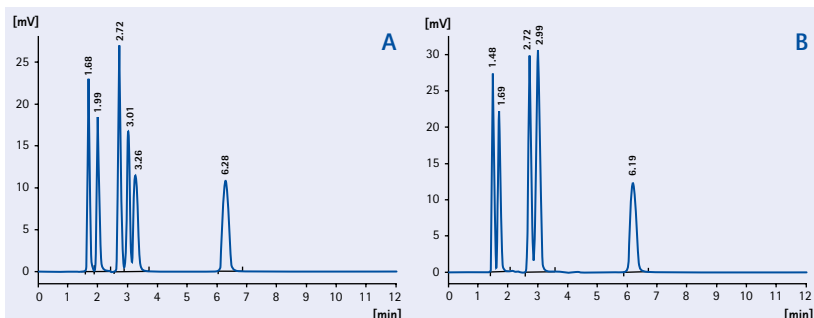

Column L

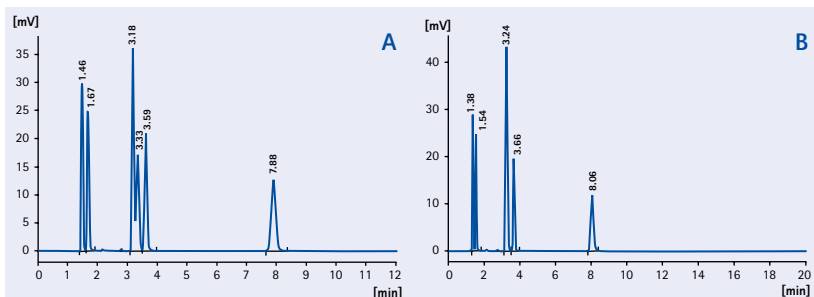

Stability test for efficiency and retention time over 15,000 column volumes (115 h)



Stability test

Column	LiChroCART® 55-4 Purospher® STAR RP-18 endcapped, 3 µm
Mobile phase	0.1 v/v% H ₃ PO ₄ in Water
Flow rate	1.5 mL/min
Temperature	60°C
Sample	Amitriptyline Valerophenone o-Nitrophenol

The combination of extremely high purity silica, best all-round retention characteristics, outstanding pH stability up to pH 10.5 and suitability for use with 100% aqueous mobile phases makes Purospher® STAR RP-18 endcapped an all-round top performance column, almost universal in its range of applications.

Separation examples on Purospher® STAR RP-18e Triptylines

Column	LiChroCART® 150-4.6 Purospher® STAR RP-18 endcapped, 5 µm
Mobile phase	A: Methanol B: 0.02 M Phosphate buffer pH 7.5
Gradient	0 min 80% A, 15 min 100% A
Flow rate	1.0 mL/min
Detection	UV 220 nm
Temperature	30°C
Injection volume	10 µL
Sample	1. Protriptyline 2. Nortriptyline 3. Doxepin 4. Imipramine 5. Amitriptyline

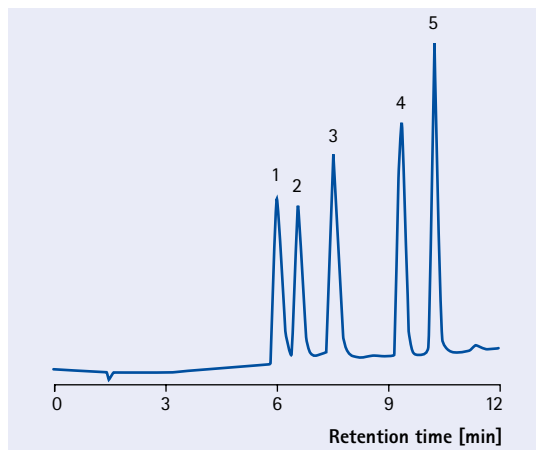

Flavonoids

Column	LiChroCART® 150-4.6 Purospher® STAR RP-18 endcapped, 5 µm
Mobile phase	A: Acetonitrile B: 0.1% Phosphoric acid
Gradient	0 min 40% A, 3 min 40% A, 8 min 50% A
Flow rate	1.0 mL/min
Detection	UV 365 nm
Temperature	30°C
Injection volume	10 µL
Sample	1. Rutin 2. Morin 3. Quercetin 4. 3-Hydroxyflavon

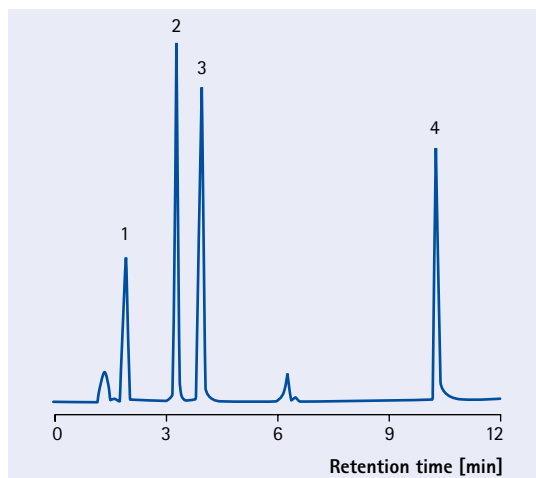

Contents of energy drinks

Column	LiChroCART® 150-4.6 Purospher® STAR RP-18 endcapped, 5 µm
Mobile phase	A: Acetonitrile B: 0.02 M Phosphate buffer pH 5.0
Gradient	0 min 15% A, 3 min 15% A, 10 min 30% A
Flow rate	1.0 mL/min
Detection	UV 227 nm
Temperature	30°C
Injection volume	10 µL
Sample	1. Acesulfame-K 23 µg/mL 2. Saccharin 29 µg/mL 3. Benzoic acid 13 µg/mL 4. Sorbic acid 14 µg/mL 5. Caffeine 47 µg/mL 6. Aspartame 100 µg/mL

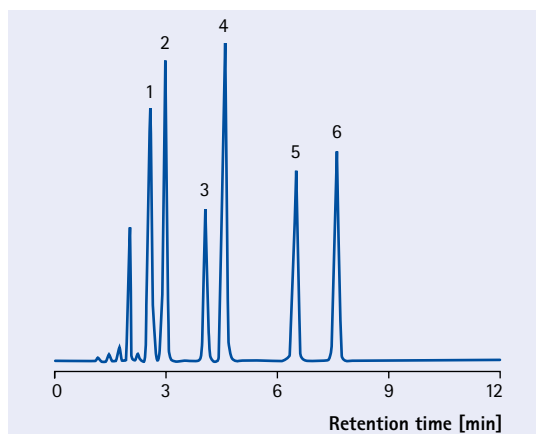

Separation of Catecholamines under aqueous conditions

Column	LiChroCART® 150-4.6 Purospher® STAR RP-18 endcapped, 5 µm	
Mobile phase	20 mM Potassium phosphate buffer pH 3.0/ Methanol (97:3)	
Flow rate	1.5 mL/min	
Detection	270 nm	
Temperature	30°C	
Injection volume	10 µL	
Sample	1. Norepinephrine	195 µg/mL
	2. Epinephrine	202 µg/mL
	3. Dopamine	214 µg/mL
	4. L-Dopa	205 µg/mL
	5. Serotonin	99 µg/mL

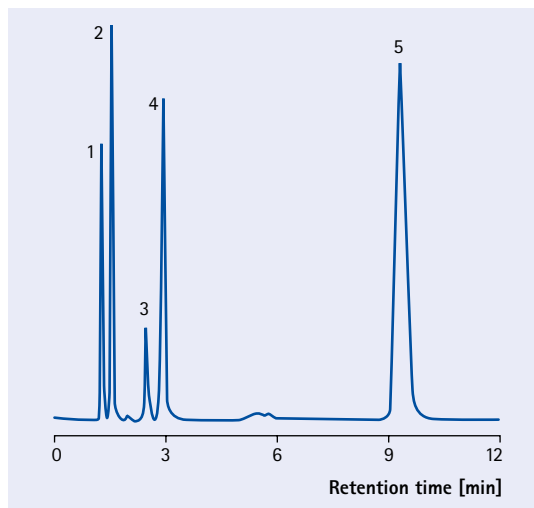

Separation of Catecholamines

Column	LiChroCART® 150-4.6 Purospher® STAR RP-18 endcapped, 5 µm	
Mobile phase	A: Acetonitrile B: 0.1% Phosphoric acid	
Gradient	0.0 min 0% A; 15.0 min 30% A	
Flow rate	1.0 mL/min	
Detection	UV 210 nm	
Temperature	30°C	
Injection volume	10 µL	
Sample	1. Norepinephrine	140 µg/mL
	2. Octopamine	160 µg/mL
	3. Epinephrine tartrate	190 µg/mL
	4. Dopamine	208 µg/mL
	5. DOPA	210 µg/mL
	6. Norephedrine	160 µg/mL
	7. Ephedrine hemihydrate	140 µg/mL
	8. N-Methylephedrine	170 µg/mL

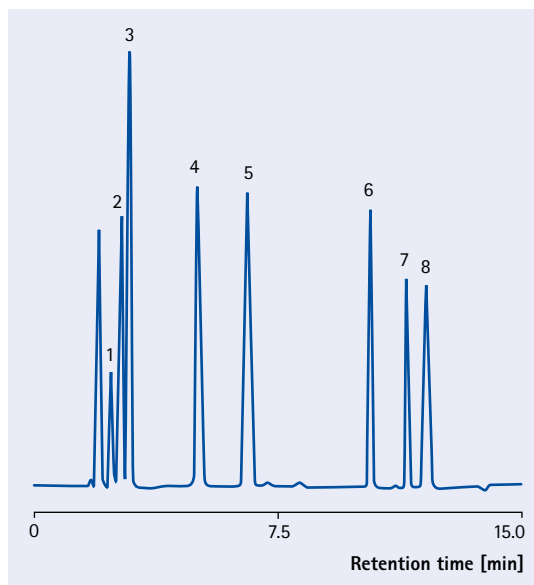

Separation examples on Purospher® STAR RP-18e Separation of Carbidopa

Column	LiChroCART® 150-4.6 Purospher® STAR RP-18 endcapped, 5 µm	
Mobile phase	A: Methanol B: 20 mM Potassium dihydrogenphosphate buffer pH 4.3	
Gradient	0.0 - 2.4 min	1% A
	2.5 - 15.0 min	14% A
Flow rate	1.0 mL/min	
Detection	UV 282 nm	
Temperature	ambient	
Injection volume	5 µL	
Sample	1. 1,2,4,5 trihydroxyphenylalanine	125 µg/mL
	2. Levodopa	235 µg/mL
	3. Methylodopa	160 µg/mL
	4. Dopamine	190 µg/mL
	5. Carbidopa	175 µg/mL
	6. 3,4-dihydroxyphenylacetic acid	185 µg/mL
	7. 3-o-Methylcarbidopa	140 µg/mL

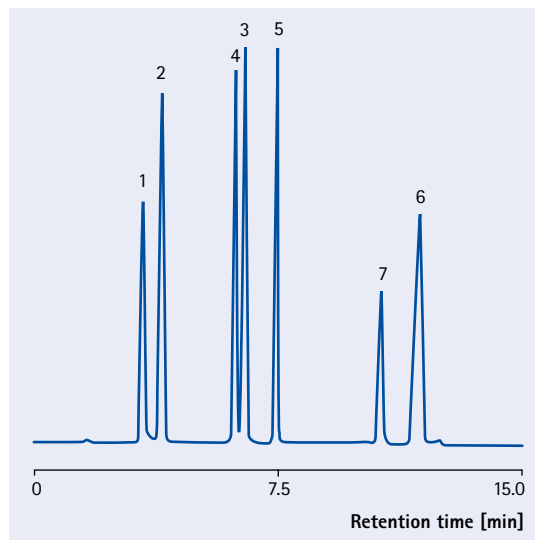

Separation of Beta-Blockers

Column	LiChroCART® 55-4 Purospher® STAR RP-18 endcapped, 3 µm	
Mobile phase	Methanol/ 0.05 M Phosphate buffer pH 3.0; 45:55 (v,v)	
Flow rate	1.0 mL/min	
Detection	UV 220 nm	
Temperature	30°C	
Sample	1. Pafenolol	
	2. Celiprolol	
	3. Bisoprolol	
	4. Metipranolol	
	5. Propranolol	
	6. Alprenolol	

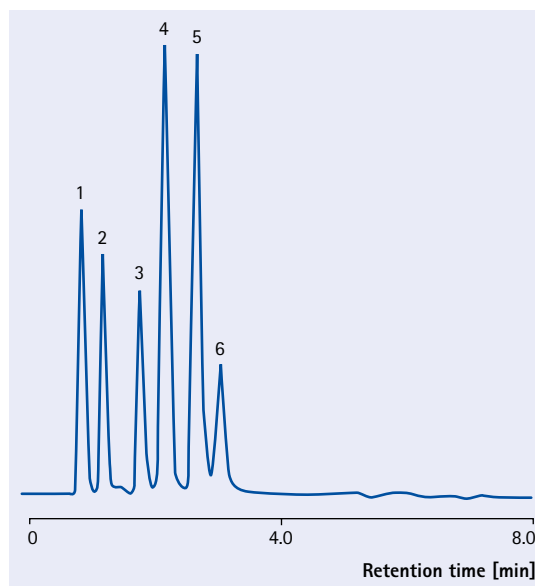

Separation of Sweeteners

Column	LiChroCART® 150-4.6 Purospher® STAR RP-18 endcapped, 5 µm
Mobile phase	Acetonitrile/ 0.1% Phosphoric acid; 40:60
Flow rate	1.0 mL/min
Detection	UV 210 nm
Temperature	30°C
Injection volume	10 µL
Sample	1. Acesulfame-K 2. Saccharin-Na 3. Diketopiperazine 4. Aspartame

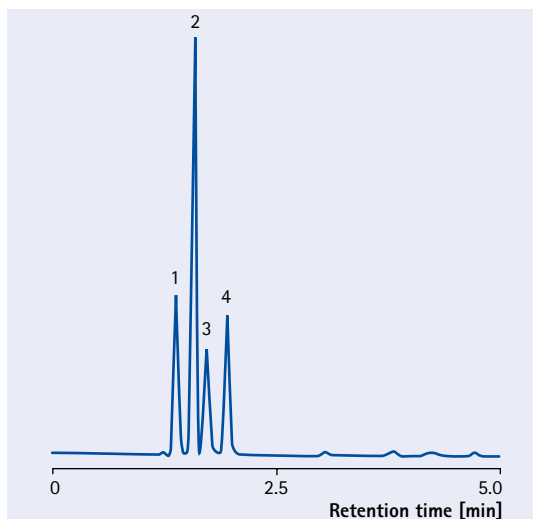

Separation of Peptides

Column	LiChroCART® 55-4 Purospher® STAR RP-18 endcapped, 3 µm
Mobile phase	A: Water + 0.1% TFA B: Acetonitrile + 0.1% TFA
Gradient	0.0 min 95% A; 10 min 80% A
Flow rate	1.0 mL/min
Detection	UV 254 nm
Temperature	23°C
Sample	1. Ala - Tyr 2. Tyr - Tyr 3. Gly - Phe - Gly 4. Leu - tyr

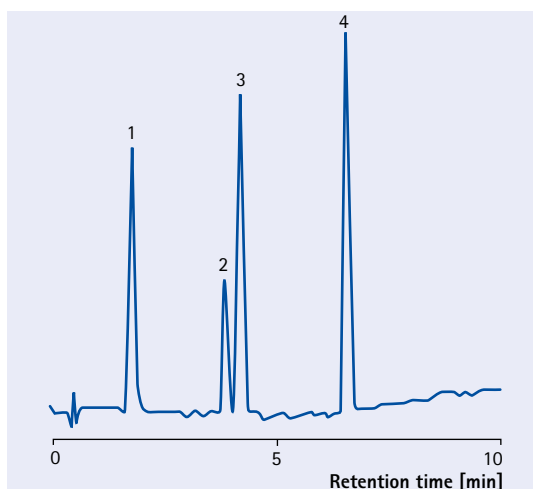

Separation of Hormones

Column	LiChroCART® 125-4 Purospher® STAR RP-18 endcapped, 5 µm
Mobile phase	Acetonitrile/ 0.01 M Phosphate buffer pH 7.0; 54:46
Flow rate	1.0 mL/min
Detection	UV 220 nm
Temperature	30°C
Sample	1. Prednisolone 2. Beta-Estradiol 3. 12-alpha-ethinyl-estradiol 4. Estrone 5. Progesterone

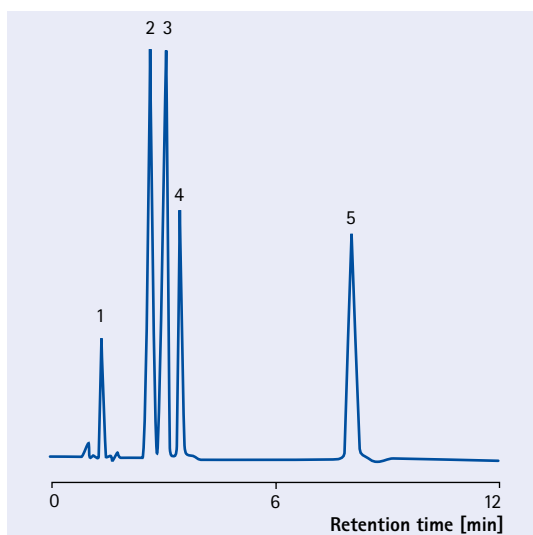

Purospher® STAR columns for LC/MS applications

"Ghost" mass peaks represent one problem frequently encountered in gradient LC/MS. It is impossible to differentiate whether these ghost peaks are originating from an unknown compound in the sample, from an impurity in the mobile phase or from bonded phase leaching.

To solve the problem of spurious LC/MS peaks, a three-step procedure is proposed for consistently running of ghost-peak-free HPLC. It includes cleaning the columns and choosing appropriate solvents for LC/MS applications, thus increasing ionization efficiency. Hence, both sensitivity and reproducibility of LC/MS results are improved.

A simple, easy to follow 3-step process optimizes performance in LC/MS

1. Flush the column for 60 minutes with a special solvent mixture to remove possible trace impurities. The recommended LC/MS wash solvent is 2-propanol with 0.1% formic acid at a flow rate of 0.5 mL/min (for 3 mm i.d. columns).
2. To reduce the LC/MS background signal, work with extremely highly purified solvents. The recommended solvent is LiChrosolv® hypergrade with special MS specifications.
3. Finally, the column must be re-equilibrated with the mobile phase. Best results are obtained when two blank solvent gradients (without sample injection) are run prior to analysis. Purospher® STAR RP-18 end-capped HPLC columns give ideally low and very stable background signals in LC/MS, **simply after washing with 2-propanol / 0.1% formic acid.**

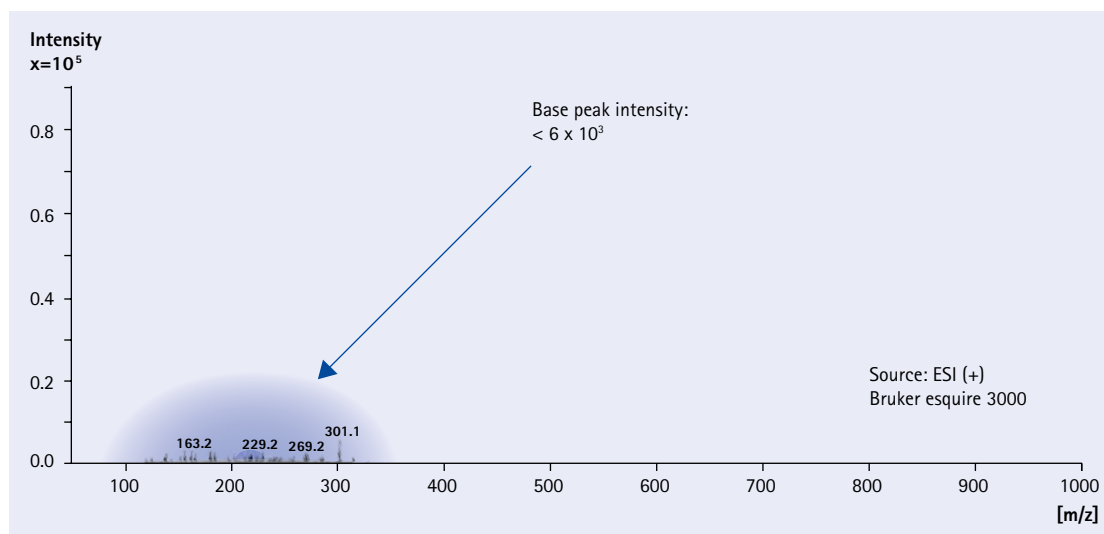

Extracted ion chromatograms of "profens" in negative ion mode separated on Purospher® STAR RP-18 endcapped

Chromatographic conditions

Column	LiChroCART® 55-2 Purospher® STAR RP-18 endcapped, 3 µm	
Mobile phase	A: 0.1% Acetic acid in Acetonitrile B: 0.1% Acetic acid in Water	
Gradient	From 25% A to 50% A in 3 min, then isocratic	
Flow rate	300 µL, without split	
Detection	UV 220 nm, Ion Trap MS	
Temperature	ambient	
Inj. volume	1 µL	
Sample	1. Ketoprofen	0.1 µg/µL
	2. Fenoprofen	0.1 µg/µL
	3. Ibuprofen	0.1 µg/µL

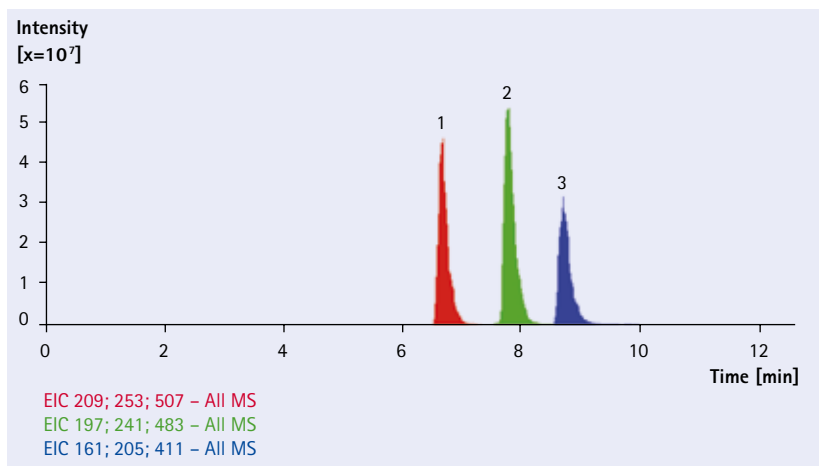

MS conditions

Ionization	ESI(-)
Nebulizer	36 psi
Dry gas	8.5 L/min
Dry temperature	330°C
Smart mode optimisation	Target mass 205
Ion charge control	Target 50,000, max 50 ms
Scan mode	Standard/Normal
Scan range	50-600 m/z

Ketoprofen, Fenoprofen and Ibuprofen (100 ng) give ghost-peak-free MS spectra using LiChrosolv® Acetonitrile hypergrade and Purospher® STAR RP-18 endcapped columns.

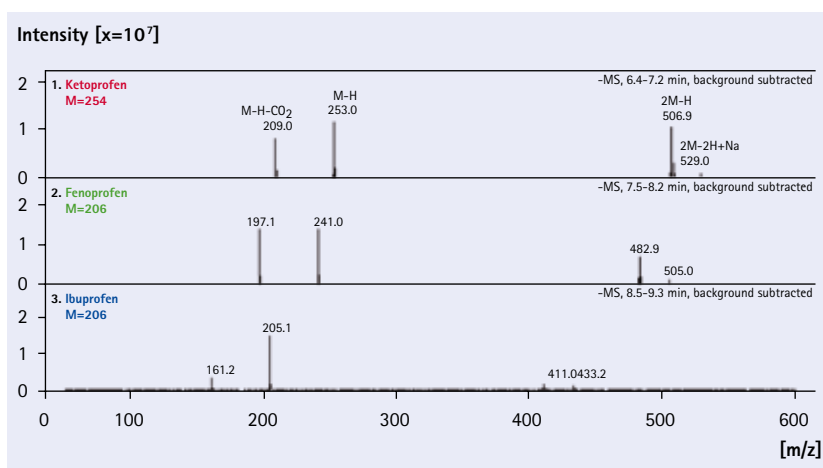

Purospher® STAR UHPLC columns for ultra fast HPLC

Where speed meets performance

Speed, resolution and sensitivity

Available as optimized 2 µm particulate silica, these UHPLC columns based on Purospher® STAR RP-18 endcapped are ideal for ultra-fast applications, where resolution, sensitivity and sample throughput are crucial. They are the first choice for high-throughput screening & QC analyses, process monitoring, method development, and LC/MS applications. Due to its balanced selectivity, Purospher® STAR RP-18 endcapped UHPLC columns cover almost all demanding separations with tailing-free chromatograms. **The Purospher® STAR RP-18 endcapped 3 µm columns are recommended for difficult samples where clogging and back-pressure present an issue.**

Purospher® STAR UHPLC columns benefits

- In UHPLC environment, speed is increased by a factor of 10
- Solvent consumption is drastically cut (up to 85%)
- Excellent peak shape for all types of acidic, basic and metal chelating analytes due to high purity silica
- Extraordinary pH stability from pH 1.5 – 10.5 for an extremely wide application range
- Enhanced sensitivity due to improved signal-to-noise ratio



Specification of Hibar® HR Purospher® STAR RP-18 endcapped

Sorbent characteristics	High purity C18-modified silica with endcapping	
Particle size	2 µm and 3 µm	
Pore size	12 nm (120 Å)	
Pore volume	1.1 mL/g	
Specific surface area	330 m ² /g	
Carbon load	17%	
Coverage of the surface	3 µmol/m ²	
Efficiency	2 µm	> 180,000 N/m
	3 µm	> 130,000 N/m
pH range	pH 1.5 - 10.5	
Pressure stability	600 bar	

Ordering information – Purospher® STAR RP-18 endcapped, stainless steel Hibar® HR UHPLC columns

Product	Ordering No	Particle size	Dimension length	Dimension i.d.	Contents of one package
Purospher® STAR RP-18 endcapped	1.50645.0001	2 µm	30 mm	2.1 mm	1 piece
Purospher® STAR RP-18 endcapped	1.50646.0001	2 µm	50 mm	2.1 mm	1 piece
Purospher® STAR RP-18 endcapped	1.50648.0001	2 µm	100 mm	2.1 mm	1 piece
Purospher® STAR RP-18 endcapped	1.50649.0001	2 µm	150 mm	2.1 mm	1 piece
Purospher® STAR RP-18 endcapped	1.50650.0001	3 µm	30 mm	2.1 mm	1 piece
Purospher® STAR RP-18 endcapped	1.50651.0001	3 µm	50 mm	2.1 mm	1 piece
Purospher® STAR RP-18 endcapped	1.50653.0001	3 µm	100 mm	2.1 mm	1 piece
Purospher® STAR RP-18 endcapped	1.50654.0001	3 µm	150 mm	2.1 mm	1 piece
Purospher® STAR RP-18 endcapped	1.50655.0001	3 µm	250 mm	2.1 mm	1 piece

► **Purospher® STAR RP-18 endcapped**
The versatility you need!
page 219

High resolution separation of 9 Alkylphenones

LiChroCART® 150-4.6

Purospher® STAR RP-18 endcapped, 5 µm

Column	LiChroCART® 150-4.6 Purospher® STAR RP-18 endcapped, 5 µm
Mobile phase	A: Water B: Acetonitrile
Gradient	0 min 45% B 15 min 45 - 95% B 15.1-20 min re-equilibration with 45% B
Flow rate	1.0 mL/min
Pressure	105 bar
Detection	UV 247 nm
Temperature	40°C
Injection volume	10 µL
Sample	1. Acetanilide 2. Acetophenone 3. Propiophenone 4. Butyrophenone 5. Benzophenone 6. Valerophenone 7. Hexanophenone 8. Heptanophenone 9. Ocatanophenone

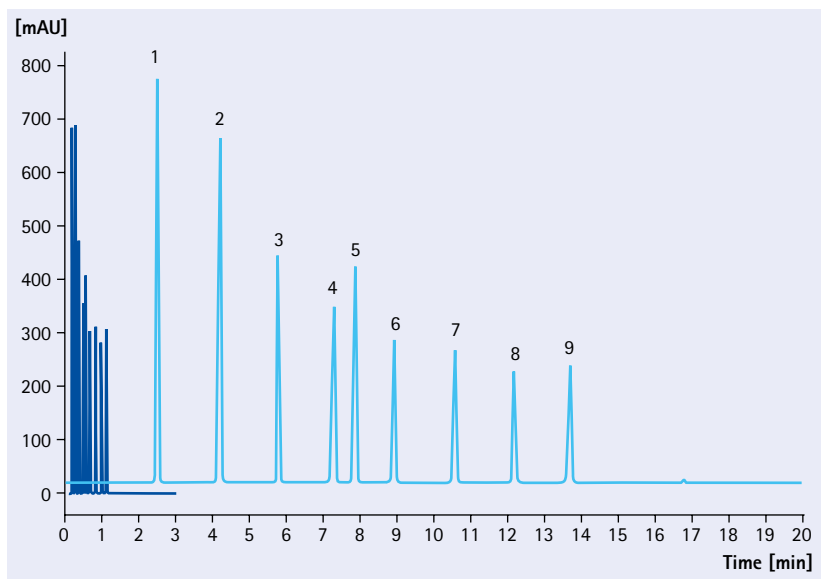

Hibar® HR 50-2.1

Purospher® STAR RP-18 endcapped, 2 µm

Column	Hibar® HR 50-2.1 Purospher® STAR RP-18 endcapped, 2 µm
Mobile phase	A: Water B: Acetonitrile
Gradient	0 min 55% B 0.8 min 55-100% B 0.9-2 min re-equilibration with 55% B
Flow rate	1.1 mL/min
Pressure	505 bar
Detection	UV 247 nm
Temperature	40°C
Injection volume	1 µL
Sample	1. Acetanilide 2. Acetophenone 3. Propiophenone 4. Butyrophenone 5. Benzophenone 6. Valerophenone 7. Hexanophenone 8. Heptanophenone 9. Ocatanophenone

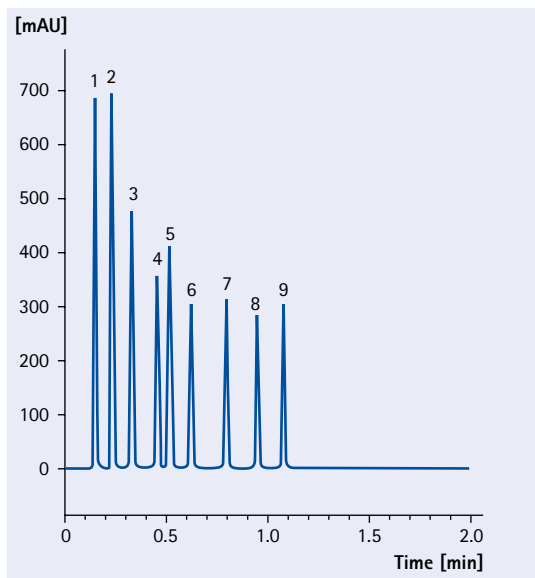

Purospher® STAR RP-8 endcapped

Optimized for more polar compounds

Purospher® STAR RP-8 endcapped, like Purospher® STAR RP-18 endcapped, is based on high purity silica and an almost complete surface coverage. Thus, Purospher® STAR RP-8 provides excellent peak symmetry for acidic, basic and even chelating compounds, highest column efficiency in terms of the number of theoretical plates, and exceptional stability from pH 1.5 to 10.5.

In addition, Purospher® STAR RP-8 endcapped columns offer a wide applicability. As the sorbent is less hydrophobic than Purospher® STAR RP-18 endcapped, analytes will typically elute faster on the C8 phase. Purospher® STAR RP-8 endcapped provides enhanced selectivity for positional isomers, and symmetrical peak shapes for strongly basic and polar compounds. Like all other Purospher® HPLC columns, Purospher® STAR RP-8 endcapped columns are available in a large number of different hardware formats.

Purospher® STAR RP-8 endcapped benefits

- Enhanced selectivity for positional isomers
- Excellent peak symmetry for polar and basic compounds

Specification of Purospher® STAR RP-8 endcapped

Sorbent characteristics	High purity C8-modified silica gel with endcapping	
Metal content	Na, Ca, Mg, Al: 1 ppm; Fe: 3 ppm	
Particle shape	spherical	
Particle size	3 µm and 5 µm	
Pore size	12 nm (120 Å)	
Pore volume	1.1 mL/g	
Specific surface area	330 m ² /g	
Carbon load	17%	
Coverage of the surface	3 µmol/m ²	
Efficiency	3 µm	> 130,000 N/m
	5 µm	> 80,000 N/m
pH range	pH 1.5 - 10.5	
Shipping eluent	Acetonitrile/Water	

Separation examples Purospher® STAR RP-8 endcapped Caffeine & derivatives

Column	LiChroCART® 125-4 Purospher® STAR RP-8 endcapped, 5 µm
Mobile phase	Methanol/Ammonia Acetate Buffer pH 3.5 (Gradient)
Flow rate	1.0 mL/min
Detection	UV 270 nm
Temperature	ambient
Injection volume	10 µL
Sample	1. 1-Methylxanthine 2. 1,3-Dimethyl uric acid 3. Paracetamol 4. Theobromine 5. 1,7-Dimethyl uric acid 6. 1,7-Dimethyl xanthine 7. Theophylline 8. Caffeine

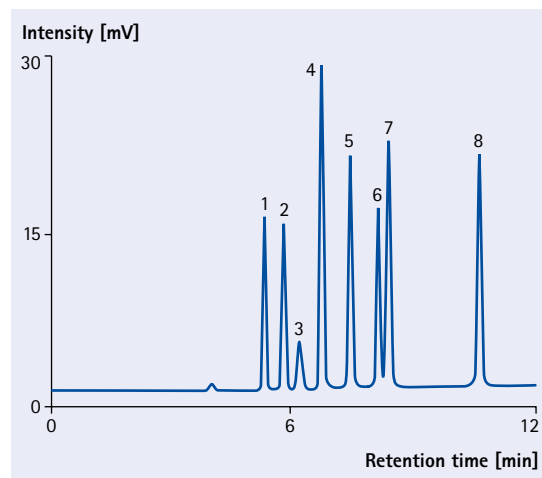

► Customized packings
Always the right column
page 292

Ordering information – Purospher® STAR RP-8 endcapped, stainless steel cartridges LiChroCART®

Product	Ordering No.	Particle size	Dimension length	Dimension i.d.	Contents of one package
Purospher® STAR RP-8 endcapped custom packed	1.50229.7220	3 µm	30 mm	2 mm	1 piece
Purospher® STAR RP-8 endcapped custom packed	1.50234.7220	3 µm	55 mm	2 mm	1 piece
Purospher® STAR RP-8 endcapped custom packed	1.50302.7220	3 µm	30 mm	4 mm	1 piece
Purospher® STAR RP-8 endcapped custom packed	1.50228.7220	3 µm	55 mm	4 mm	1 piece
Purospher® STAR RP-8 endcapped custom packed	1.50171.7220	3 µm	75 mm	4 mm	1 piece
Purospher® STAR RP-8 endcapped	1.50274.0001	5 µm	125 mm	2 mm	1 piece
Purospher® STAR RP-8 endcapped	1.50275.0001	5 µm	250 mm	2 mm	1 piece
Purospher® STAR RP-8 endcapped	1.50038.0001	5 µm	125 mm	3 mm	1 piece
Purospher® STAR RP-8 endcapped	1.50273.0001	5 µm	250 mm	3 mm	1 piece
Purospher® STAR RP-8 endcapped	1.50270.0001	5 µm	4 mm	4 mm	10 pieces
Purospher® STAR RP-8 endcapped	1.50271.0001	5 µm	125 mm	4 mm	1 piece
Purospher® STAR RP-8 endcapped	1.50272.0001	5 µm	250 mm	4 mm	1 piece
Purospher® STAR RP-8 endcapped	1.50031.0001	5 µm	150 mm	4.6 mm	1 piece
Purospher® STAR RP-8 endcapped	1.50032.0001	5 µm	250 mm	4.6 mm	1 piece
Purospher® STAR RP-8 endcapped	1.50276.0001	5 µm	250 mm	10 mm	1 piece

The LiChroCART® columns (75, 125, 150 and 250 mm length) in the list above (2, 3, 4 and 4.6 mm i.d.) require part number 1.51486.0001 manu-CART® cartridge column holder, which can be used to hold one cartridge column with or without a 4–4 mm guard column. LiChroCART® columns 250–10 mm require part number 1.51419.0001 manu-CART® 10. The short LiChroCART® columns (30 and 55 mm length) can be ordered as a set including the corresponding cartridge holder and one cartridge, or as a pack of 3 cartridges without cartridge holder. Additional dimensions available as customized packings see page 292.

The separate part numbers for the cartridge are as follows. 1.50227.0001 LiChroCART® cartridge holder for 30 mm cartridge. 1.50226.0001 LiChroCART® cartridge holder for 55 mm cartridge.

Ordering information – Purospher® STAR RP-8 endcapped, stainless steel columns Hibar® RT

Product	Ordering No.	Particle size	Dimension length	Dimension i.d.	Contents of one package
Purospher® STAR RP-8 endcapped	1.50033.0001	5 µm	125 mm	4 mm	1 piece
Purospher® STAR RP-8 endcapped	1.50035.0001	5 µm	250 mm	4 mm	1 piece
Purospher® STAR RP-8 endcapped	1.51453.0001	5 µm	150 mm	4.6 mm	1 piece
Purospher® STAR RP-8 endcapped	1.51454.0001	5 µm	250 mm	4.6 mm	1 piece

The Hibar® RT columns are complete with endfittings. When using a guard column with a Hibar® RT column, we recommend part number 1.51487.0001 guard column cartridge holder for 4–4 mm guard column cartridges LiChroCART®. Additional dimensions available as customized packings see page 292.

Purospher® STAR Si (Silica) and NH₂ (Amino-phase)



Purospher® STAR HPLC columns based on highest purity silica are also available for normal phase separations. **Purospher® STAR Si** (Silica) offers highest separation efficiency for normal-phase chromatography of low molecular weight compounds soluble in organic solvents.

Purospher® STAR NH₂ (Amino-phase) is primarily designed for carbohydrate analysis with a typical mobile phase consisting of acetonitrile and water. Additionally, Purospher® STAR NH₂ can also be used in the normal-phase retention mode.

Purospher® STAR Si and Purospher® STAR NH₂ benefits

- Very high separation efficiency as measured by the plate count
- Absence of metal impurities, thus giving consistently symmetrical peaks
- Extended column lifetime

Specifications of Purospher® STAR Si and Purospher® STAR NH₂

	Purospher® STAR Si	Purospher® STAR NH ₂
Sorbent characteristics	High-purity silica gel particles	with NH ₂ (Amino) modification
Metal content	Na, Ca, Mg, Al: 1 ppm; Fe: 3 ppm	Na, Ca, Mg, Al: 1 ppm; Fe: 3 ppm
Particle shape	spherical	spherical
Particle size	5 µm	5 µm
Pore size	12 nm (120 Å)	12 nm (120 Å)
Pore volume	1.1 mL/g	1.1 mL/g
Specific surface area	330 m ² /g	330 m ² /g
Carbon load	–	3.5%
Coverage of the surface	3 µmol/m ²	3 µmol/m ²
Efficiency	> 50,000 N/m	> 50,000 N/m
pH range	pH 2 - 7.5	pH 2 - 7.5
Shipping eluent	n-Heptane	n-Heptane

Ordering information – Purospher® STAR Si and Purospher® STAR NH₂, stainless steel cartridges LiChroCART®

Product	Ordering No.	Particle size	Dimension length	Dimension i.d.	Contents of one package
Purospher® STAR Si	1.50249.0001	5 µm	4 mm	4 mm	10 pieces
Purospher® STAR Si	1.50268.0001	5 µm	125 mm	4 mm	1 piece
Purospher® STAR Si	1.50269.0001	5 µm	250 mm	4 mm	1 piece
Purospher® STAR Si	1.50356.0001	5 µm	150 mm	4.6 mm	1 piece
Purospher® STAR Si	1.50357.0001	5 µm	250 mm	4.6 mm	1 piece
Purospher® STAR NH ₂	1.50267.0001	5 µm	4 mm	4 mm	10 pieces
Purospher® STAR NH ₂	1.50244.0001	5 µm	125 mm	4 mm	1 piece
Purospher® STAR NH ₂	1.50245.0001	5 µm	250 mm	4 mm	1 piece
Purospher® STAR NH ₂	1.50247.0001	5 µm	150 mm	4.6 mm	1 piece
Purospher® STAR NH ₂	1.50248.0001	5 µm	250 mm	4.6 mm	1 piece

The LiChroCART® columns (75, 125, 150 and 250 mm length) in the list above (4 mm i.d.) require part number 1.51486.0001 manu-CART® cartridge column holder, which can be used to hold one cartridge column with or without a 4–4 mm guard column. Additional dimensions available as customized packings see page 292.

▶ **LiChrospher® 100 NH₂**
A versatile sorbent for both reversed phase and normal phase chromatography
page 269

▶ **Customized packings**
Always the right column
page 292

Separation examples on Purospher® STAR Si and Purospher® STAR NH₂

Carbohydrates

Column	LiChroCART® 250-4 Purospher® STAR NH ₂ , 5 µm
Mobile phase	Acetonitrile / Water 75:25
Flow rate	1.0 mL/min
Detection	RI
Temperature	30°C
Injection volume	10 µL
Sample	1. Xylose 2. Fructose 3. Glucose 4. Saccharose 5. Maltose 6. Lactose

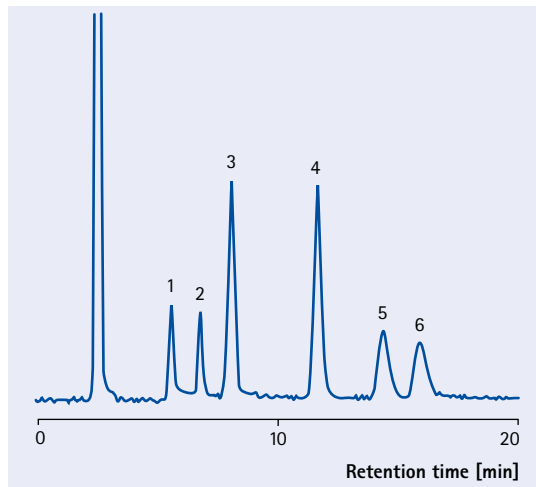

Anisols

Column	LiChroCART® 125-4 Purospher® STAR Si, 5 µm
Mobile phase	Heptane/Dioxane 95/5 v/v
Flow rate	2 mL/min
Detection	UV 254 nm response fast
Temperature	Room temperature
Injection volume	5 µL
Sample	1. Anisol 2. 3-Nitroanisol 3. 4-Nitroanisol 4. 2-Nitroanisol

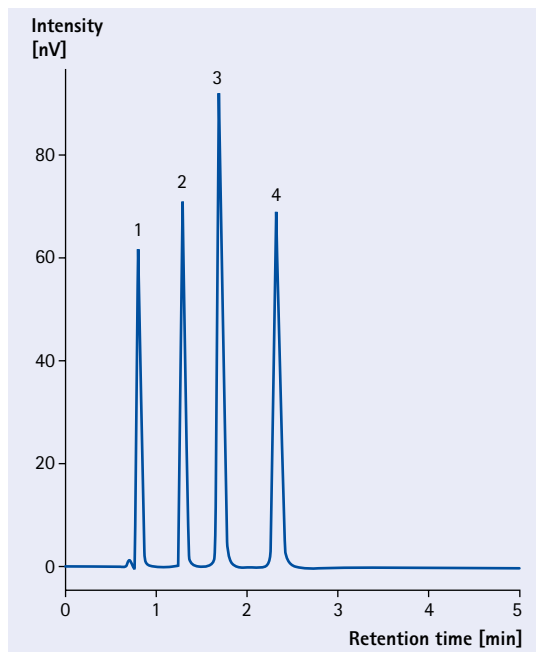

Purospher® RP-18 endcapped

Excellent peak symmetry with either basic or strongly acidic compounds

Purospher® RP-18 endcapped is a versatile HPLC column providing separations with excellent peak symmetry for both basic and strongly acidic compounds. Simply composed eluents can be employed for the separation of basic drugs. This results in shorter analysis time and increases laboratory productivity. The excellent balance of chromatographic properties is the key for better separating complex samples with simple, neutral eluents. Purospher® RP-18 endcapped is based upon a high purity, metal-free silica with a complete coverage of the silica surface with C18-ligands. This enables a peak-tailing free elution of acidic, basic, and chelating compounds. Key applications are the determination of various azo dyestuff amines and beta-blockers demonstrating the good resolution and high peak symmetry.

Additionally, the chemical stability of Purospher® RP-18 endcapped is high. Mobile phase conditions at pH 8 could be applied for a long period of time without loss of performance. Purospher® RP-18 endcapped columns have excellent selectivity and column efficiency – allowing robust method development in R&D and QC.

Purospher® RP-18 endcapped benefits

- Excellent column selectivity for both basic and strongly acidic drugs
- Robust and fast method development with simple, neutral eluents

Specifications of Purospher® RP-18 endcapped

Sorbent characteristics	High-purity silica particles C18 with special modification and deactivation of the surface
Metal content	Na, Ca, Mg, Al: 1 ppm; Fe: 3 ppm
Particle shape	spherical
Particle size	5 µm
Pore size	9 nm (90 Å)
Pore volume	1.05 mL/g
Specific surface area	480 m ² /g
Carbon load	18.0% C
Efficiency	80,000 N/m
pH range	pH 2 - 8
Shipping eluent	Acetonitrile/Water

Ordering information – Purospher® RP-18 endcapped, stainless steel cartridges LiChroCART®

Product	Ordering No.	Particle size	Dimension length	Dimension i.d.	Contents of one package
Purospher® RP-18 endcapped	1.50798.0001	5 µm	125 mm	3 mm	1 piece
Purospher® RP-18 endcapped	1.50799.0001	5 µm	125 mm	3 mm	3 pieces
Purospher® RP-18 endcapped	1.51384.0001	5 µm	250 mm	3 mm	1 piece
Purospher® RP-18 endcapped	1.50167.0001	5 µm	4 mm	4 mm	10 pieces
Purospher® RP-18 endcapped	1.50168.0001	5 µm	125 mm	4 mm	1 piece
Purospher® RP-18 endcapped	1.50169.0001	5 µm	250 mm	4 mm	1 piece

The LiChroCART® columns (75, 125, 150 and 250 mm length) in the list above (4 mm i.d.) require part number 1.51486.0001 manu-CART® cartridge column holder, which can be used to hold one cartridge column with or without a 4–4 mm guard column. Additional dimensions available as customized packings see page 292.

► Purospher® STAR RP-18 endcapped
The versatility you need!
page 219

► Purospher® RP-18
Accelerate and simplify method development for basic compounds
page 242

► LiChrospher® 60 RP-select B
Excellent separations even with basic compounds
page 264

► Aluspher®
Alkaline stable HPLC separations
page 275

► Customized packings
Always the right column
page 292

Accessories for particulate HPLC columns:

► manu-CART® cartridge holder for LiChroCART® cartridges
page 296

► LiChroCART® cartridge
Different lengths, different internal diameter
page 299

Separation examples on Purospher® RP-18 endcapped

Amines from Azo Dyes

Column	LiChroCART® 125-4 Purospher® RP-18 endcapped, 5 µm	
Mobile phase	A: Acetonitrile B: 20 mM Phosphate buffer pH 7.0 (H ₃ PO ₄ with ammonia)	
Gradient	0.0 - 19.9 min	25% A
	19.9 - 20.0 min	28 - 60% A
	20.0 - 30.0 min	60% A
Flow rate	1.0 mL/min	
Detection	UV 254 nm	
Temperature	55°C	
Injection volume	10 µL	
Sample	<ol style="list-style-type: none"> 1. 2,4-Diaminoanisole 2. 2,4-Diaminotoluene 3. 4,4'-Oxydianiline 4. Benzidine 5. o-Toluidine 6. 4,4'-Diaminodiphenylmethane 7. p-Chloroaniline 8. p-Cresidine 9. 3,3'-Dimethoxybenzidine 10. 4,4'-Thiodianiline 11. 3,3'-Dimethylbenzidine 12. 2-Naphthylamine 13. 4-Chloro-o-toluidine 14. 2,4,5-Trimethylaniline 15. 4,4'-Diamino-3,3'-dimethyldiphenylmethane 16. 4-Aminobiphenyl 17. 3,3'-Dichlorobenzidine 18. 4,4'-Diamino-3,3'-dichlorodiphenylmethane 	

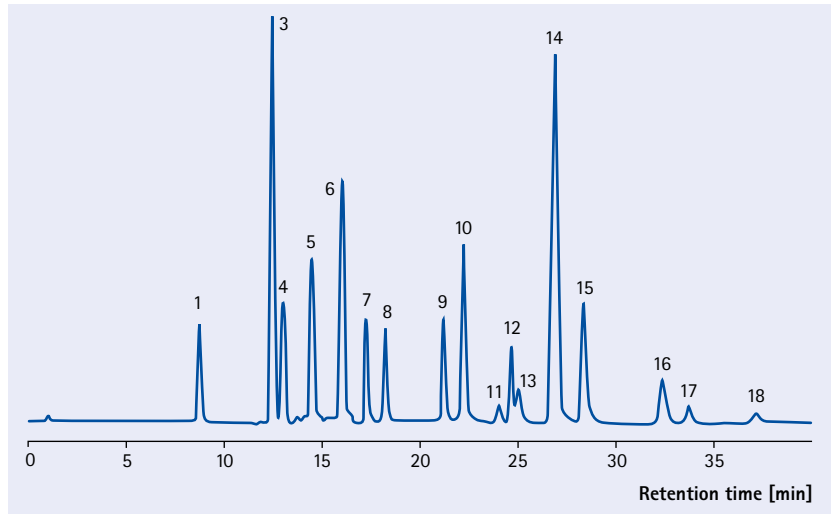

Beta-Blockers

Column	LiChroCART® 125-4 Purospher® RP-18 endcapped, 5 µm	
Mobile phase	Methanol/0.05 M Phosphate buffer pH 3.0 45/55 (v/v)	
Flow rate	0.5 mL/min	
Detection	UV 265 nm	
Temperature	32°C	
Injection volume	2 µL	
Sample	<ol style="list-style-type: none"> 1. Practolol 2. Pafenolol 3. Metoprolol 4. Celiprolol 5. Carazolol 	<ol style="list-style-type: none"> 6. Bisoprolol 7. Metipranolol 8. Propanolol 9. Alprenolol 10. Carvedilol

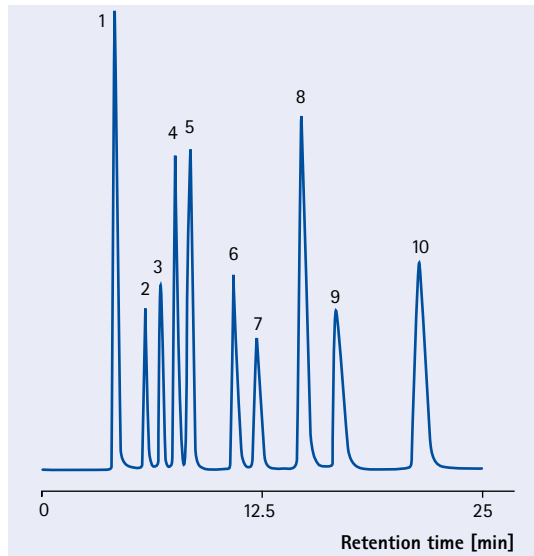

Purospher® RP-18

Accelerate and simplify method development for basic compounds

Purospher® RP-18 is designed for peak-tailing free chromatography of strongly basic compounds with simple, neutral mobile phases. Thus, method development time and consequently analyses costs are reduced. Additionally, Purospher® RP-18 allows the separation of hydrophilic compounds using up to 100% aqueous eluents.

The key for understanding the properties of Purospher® RP-18 lies in the chemistry of the base, high purity silica with virtually no metal contaminants present. In addition, multi-step chemical modification and deactivation by polymeric coating and amino shielding of the surface eliminate unpredictable interactions from residual silanols. This results in symmetric peak shapes of basic and chelating analytes without the addition of any modifiers to the mobile phase. Due to the amino endcapping step, Purospher® RP-18 is not suitable for the separation of acidic compounds. The high chemical stability of Purospher® RP-18 permits the usage of mobile phase conditions at pH 8 for a long period of time without decline of performance.

Purospher® RP-18 benefits

- Symmetrical peaks for basic, chelating, and polar analytes
- Fast method development for basic compounds

Specifications of Purospher® RP-18

Sorbent characteristics	High-purity silica particles with C18 modification and deactivation of the surface; amino shielding not suitable for acidic compounds!
Particle shape	spherical
Particle size	5 µm
Pore size	9 nm (90 Å)
Pore volume	1.05 mL/g
Specific surface area	480 m ² /g
Carbon load	17% C
Efficiency	80,000 N/m
pH range	pH 2 - 8
Shipping eluent	Acetonitrile/Water

Ordering information – Purospher® RP-18, stainless steel cartridges LiChroCART®

Product	Ordering No.	Particle size	Dimension length	Dimension i.d.	Contents of one package
Purospher® RP-18	1.50141.0001	5 µm	4 mm	4 mm	10 pieces
Purospher® RP-18	1.50142.0001	5 µm	125 mm	4 mm	1 piece
Purospher® RP-18	1.50144.0001	5 µm	250 mm	4 mm	1 piece

The LiChroCART® columns (75, 125, 150 and 250 mm length) in the list above (4 mm i.d.) require part number 1.51486.0001 manu-CART® cartridge column holder, which can be used to hold one cartridge column with or without a 4-4 mm guard column. Additional dimensions available as customized packings see page 292.

▶ **Purospher® STAR RP-18 endcapped**
The versatility you need!
page 219

▶ **Purospher® RP-18 endcapped** Excellent peak symmetry with either basic or strongly acidic compounds
page 240

▶ **LiChrospher® 60 RP-select B** Excellent separations even with basic compounds
page 264

▶ **Aluspher®** Alkaline stable HPLC separations
page 275

▶ **Customized packings** Always the right column
page 292

Accessories for particulate HPLC columns:

▶ **manu-CART® cartridge holder** for LiChroCART® cartridges
page 296

▶ **LiChroCART® cartridge** Different lengths, different internal diameter
page 299

Separation examples on Purospher® RP-18

Toluidines

Column	LiChroCART® 125-4 Purospher® RP-18, 5 µm
Mobile phase	Acetonitrile/Water 30/70 (v/v)
Flow rate	1.0 mL/min
Detection	UV 254 nm
Temperature	Room temperature
Injection volume	10 µL
Sample	1. Caffeine 2. Aniline 3. Pyridine 4. o-Toluidine 5. m-Toluidine 6. p-Toluidine 7. N-Methylaniline 8. 2-Ethylaniline 9. 3-Nitroanisole 10. N,N-Dimethylaniline

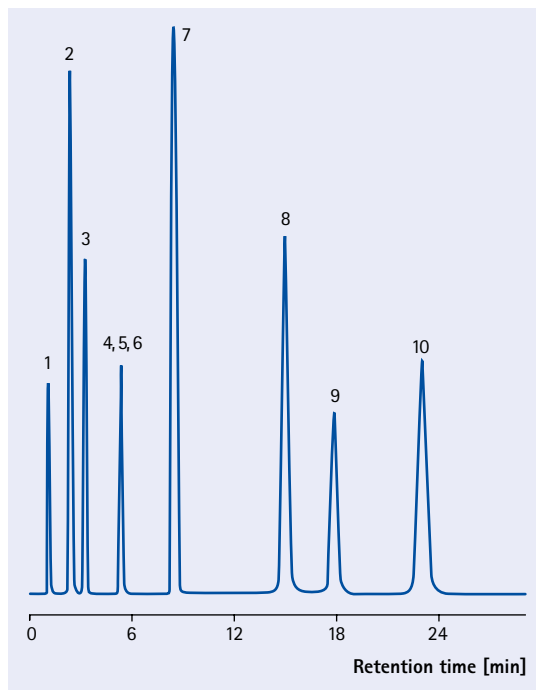

Purospher® RP-18 HC

High resolution separation of explosives and related compounds

Purospher® RP-18 HC is a non-encapped stationary phase providing high resolution for the separation of explosives and related compounds.

The determination of traces of explosives in soil and water samples in combination with solid-phase extraction is of great importance for scenarios like hazardous waste site characterization. With this HPLC column, also microbial transformation products of TNT (2-amino-4,6-dinitrotoluene [2-Am-DNT] and 4-amino-2,6-dinitrotoluene [4-Am-DNT]) and manufacturing impurities of TNT (2,4-DNT, 2,6-DNT, and 1,3-DNB) could easily be separated from each other. Purospher® RP-18 HC is also suitable for the separation of picric acid from hexyl and ethylene glycol dinitrate (EGDN) from diethylene glycol nitrate (DEGN).

Purospher® RP-18 HC benefits

- Separation of polar, non-basic analytes
- Traces determination of explosives



Specifications of Purospher® RP-18 HC

Sorbent characteristics	High-purity silica particles with dedicated RP-18 modification
Particle shape	spherical
Particle size	5 µm
Pore size	9 nm (90 Å)
Pore volume	1.05 mL/g
Specific surface area	470 m ² /g
Carbon load	18% C
pH range	pH 2 - 8
Shipping eluent	Acetonitrile/Water

Ordering information – Purospher® RP-18 HC, stainless steel cartridges LiChroCART®

Product	Ordering No.	Particle size	Dimension length	Dimension i.d.	Contents of one package
Purospher® RP-18	1.51436.0001	5 µm	250 mm	4 mm	1 piece

The LiChroCART® columns (75, 125, 150 and 250 mm length) in the list above (4 mm i.d.) require part number 1.51486.0001 manu-CART® cartridge column holder, which can be used to hold one cartridge column with or without a 4-4 mm guard column. Additional dimensions available as customized packings see page 292.

► Purospher® STAR RP-18 endcapped
The versatility you need!
page 219

► Purospher® STAR RP-8 endcapped
Optimized for more polar compounds
page 236

► Purospher® STAR Si (Silica) and NH₂ (Amino-phase)
page 238

► LiChrospher® 60 RP-select B
Excellent separations even with basic compounds
page 264

► Aluspher®
Alkaline stable HPLC separations
page 275

► Customized packings
Always the right column
page 292

Accessories for particulate HPLC columns:

► manu-CART® cartridge holder for LiChroCART® cartridges
page 296

► LiChroCART® cartridge
Different lengths, different internal diameter
page 299

Separation examples on Purospher® RP-18 HC

Separation of explosives from drinking water

Column	LiChroCART® 250-4 Purospher® RP-18 HC, 5 µm	
Mobile phase	A: Acetonitrile / Methanol; 20 / 80, v/v B: Sodium dihydrogenphosphate buffer (c = 0.01 mol/L, pH 4.5)	
Gradient	0 min 35% A; 28 min 55% A; 40 min 85% A; 50 min 85% A; 51 min 35% A; 71 min 35% A	
Flow rate	0.8 mL/min	
Detection	DAD 210 nm and 235 nm	
Temperature	36°C	
Injection volume	40 µL	
Sample	No 1.-19.	Recovery
	1. Octogen (HMX)	105%
	2. Picric acid	96%
	3. Hexogen (RDX)	107%
	4. Ethylene glycol dinitrate (EGDN)	61%
	5. Dethylene glycol dinitrate (DEGN)	95%
	6. 1,3,5-Trinitrobenzene	102%
	7. 1,3-Dinitrobenzene	96%
	8. Tetryl	91%
	9. Nitroglycerine	53%
	10. 2,4,6-Trinitrotoluene	99%
	11. 4-Amino-2,6-dinitrotoluene	106%
	12. 2-Amino-4,6-dinitrotoluene	107%
	13. 2,6-Dinitrotoluene	104%
	14. 2,4-Dinitrotoluene	104%
	15. 2-Nitrotoluene	85%
	16. 4-Nitrotoluene	88%
	17. 3-Nitrotoluene	86%
	18. Nitropenta (PETN)	106%
	19. Hexyl	73%

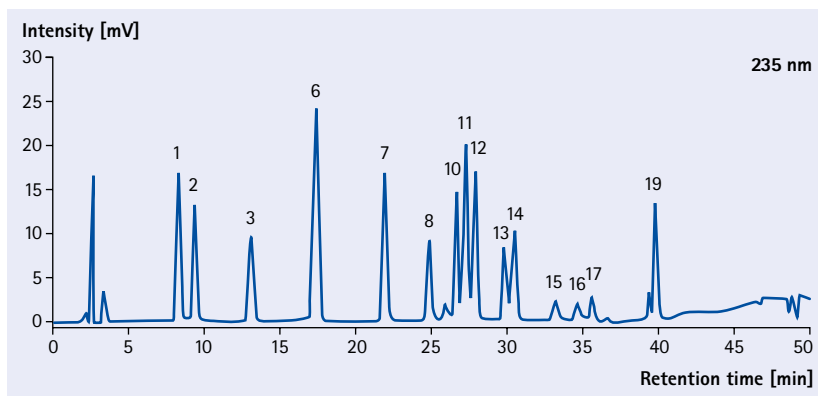
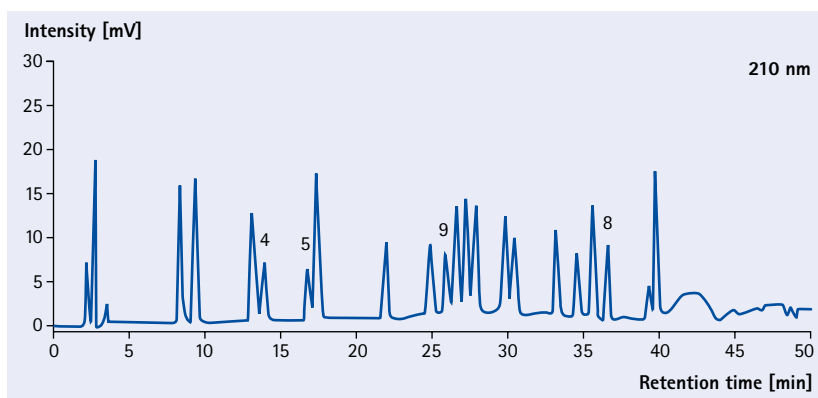

Sample preparation

Solid phase extraction	LiChrolut® EN (200 mg) [Cat. No. 119870]
Solvents	A: Methanol [LiChrosolv® Cat. No. 106007] B: Acetonitrile [LiChrosolv® Cat. No. 100030] C: Water [LiChrosolv® Cat. No. 115333]
Initial sample preparation	Filtrate if necessary and add approx. 5 g NaCl/L water sample.
Conditioning of extraction column	3 mL A 3 mL B 10 mL C Do not allow column to dry out!

Sample application	Pass 1 L water sample through the extraction column within 1 hour by using LiChrolut® extraction unit [Cat. No. 119851] which is connected to the water sample with PTFE hose [Cat. No. 122143] and a steel capillary [Cat. No. 119902]. The PTFE hose is placed through the adapter [Cat. No. 102206] which is plugged into the column.
Drying step	10 min by means of nitrogen and LiChrolut® drying unit [Cat. No. 119852].
Elution step	1 x 2 mL, then 1 x 3 mL A/B (1:1), collect in a conical flask and gently evaporate the solvent by means of nitrogen up to a volume of 0.5 mL. Fill up to 1.0 mL with C. Subsequently filtrate sample into a 1.5 mL sample vial [Cat. No. 118081] through a 0.2 µm anotop membrane filter [Cat. No. 111318].

Superspher®

Silica carrier for highly efficient separations

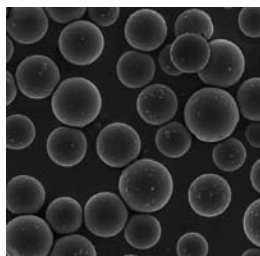

Superspher®, a high-performance spherical silica carrier with a mean particle size of 4 µm, provides an excellent pressure/separation performance ratio in terms of today's generation of HPLC systems. The number of theoretical plates for Superspher® is approx. 100,000 N/m. Thus, Superspher® columns are always the first choice when complex mixtures demand high peak capacity. **A broad range of modifications on Superspher® is available: non-polar derivatives (RP-8, RP-8 endcapped, RP-18, RP-18 endcapped and RP-select B) and polar derivatives (Si 60).**

Superspher® packing materials are available as LiChroCART® cartridges in various lengths and internal diameters (4.6 mm, 4 mm, 3 mm and 2 mm). LiChroCART® 3 mm i.d. and 2 mm i.d. narrow bore cartridges for HPLC save costs by reducing solvent consumption and allow the handling of very small quantities with excellent sensitivity and resolution. LiChroCART® cartridges 4.6 mm, 4 mm i.d., 3 mm i.d. and 2 mm i.d. are compatible with manu-CART® "4". This facilitates faster and more flexible method adaptation to smaller bore columns.

Specifications of Superspher®

Packing material	Characteristics	Spec. surface area S_{BET} [m ² /g]	Pore volume V_p [mL/g]	Particle size d_p [µm]	% C	Surface coverage [µmol/m ²]
Superspher® Si 60	spherical particles of silica medium pore size: 6 nm (60 Å)	700	0.85	4	–	–
Superspher® 60 RP-8	spherical particles of silica with octyl derivative	350	1.25	4	12.5	4.04
Superspher® 60 RP-8 endcapped	spherical particles of silica with octyl derivative endcapped	350	1.25	4	13.0	4.44
Superspher® 100 RP-18	spherical particles of silica with octadecyl derivative	350	1.25	4	21.0	3.61
Superspher® 100 RP-18 endcapped	spherical particles of silica with octadecyl derivative endcapped	350	1.25	4	21.6	4.09
Superspher® 60 RP-select B	spherical particles of silica with octyl derivative, especially suitable for the RP-separation of basic compounds	360	0.9	4	11.5	3.55



Superspher®

For highly efficient HPLC of complex mixtures
where high peak capacity required

Ordering information – Superspher® sorbents

Product	Ordering No.	Particle size	Package	Quantity
Superspher® Si 60	1.19609.0010	4 µm	Glass	10 g
Superspher® 60 RP-8	1.19612.0010	4 µm	Glass	10 g
Superspher® 60 RP-8 endcapped	1.19617.0010	4 µm	Glass	10 g
Superspher® 100 RP-18	1.19613.0010	4 µm	Glass	10 g
Superspher® 100 RP-18 endcapped	1.19618.0010	4 µm	Glass	10 g
Superspher® 60 RP-select B	1.19643.0010	4 µm	Glass	10 g

Ordering information – Superspher®, glass cartridges EcoCART®

Product	Ordering No.	Particle size	Dimension length	Dimension i.d.	Contents of one package
Superspher® 100 RP-18 endcapped	1.51423.0001	4 µm	125 mm	3 mm	1 piece
Superspher® 60 RP-select B	1.51425.0001	4 µm	125 mm	3 mm	1 piece

EcoCART® columns require part number 1.51207.0001 EcoCART® cartridge holder.



- ▶ Customized packings
Always the right column
page 292

Accessories for particulate
HPLC columns:

- ▶ manu-CART® cartridge
holder for LiChroCART®
cartridges
page 296
- ▶ LiChroCART® cartridge
Different lengths, differ-
ent internal diameter
page 299

Ordering information – Superspher®, stainless steel cartridges LiChroCART®

Product	Ordering No.	Particle size	Dimension length	Dimension i.d.	Contents of one package
Superspher® Si 60	1.16054.0001	4 µm	125 mm	4 mm	1 piece
Superspher® Si 60	1.16009.0001	4 µm	250 mm	4 mm	1 piece
Superspher® 60 RP-8	1.16052.0001	4 µm	125 mm	4 mm	1 piece
Superspher® 60 RP-8	1.16010.0001	4 µm	250 mm	4 mm	1 piece
Superspher® 60 RP-8 endcapped	1.16854.0001	4 µm	125 mm	4 mm	1 piece
Superspher® 60 RP-8 endcapped	1.16857.0001	4 µm	250 mm	4 mm	1 piece
Superspher® 100 RP-18	1.50204.0001	4 µm	10 mm	2 mm	3 pieces
Superspher® 100 RP-18	1.50200.0001	4 µm	125 mm	2 mm	1 piece
Superspher® 100 RP-18	1.50792.0001	4 µm	125 mm	3 mm	1 piece
Superspher® 100 RP-18	1.51299.0001	4 µm	250 mm	3 mm	1 piece
Superspher® 100 RP-18	1.16039.0001	4 µm	25 mm	4 mm	3 pieces
Superspher® 100 RP-18	1.50980.0001	4 µm	75 mm	4 mm	3 pieces
Superspher® 100 RP-18	1.16051.0001	4 µm	125 mm	4 mm	1 piece
Superspher® 100 RP-18	1.16056.0001	4 µm	250 mm	4 mm	1 piece
Superspher® 100 RP-18 endcapped	1.50198.0001	4 µm	125 mm	2 mm	1 piece
Superspher® 100 RP-18 endcapped	1.50193.0001	4 µm	250 mm	2 mm	1 piece
Superspher® 100 RP-18 endcapped	1.16869.0001	4 µm	25 mm	4 mm	3 pieces
Superspher® 100 RP-18 endcapped	1.16855.0001	4 µm	125 mm	4 mm	1 piece
Superspher® 100 RP-18 endcapped	1.16858.0001	4 µm	250 mm	4 mm	1 piece
Superspher® 60 RP-select B	1.50205.0001	4 µm	10 mm	2 mm	3 pieces
Superspher® 60 RP-select B	1.50197.0001	4 µm	125 mm	2 mm	1 piece
Superspher® 60 RP-select B	1.51308.0001	4 µm	250 mm	2 mm	1 piece
Superspher® 60 RP-select B	1.50791.0001	4 µm	125 mm	3 mm	1 piece
Superspher® 60 RP-select B	1.51288.0001	4 µm	250 mm	3 mm	1 piece
Superspher® 60 RP-select B	1.50974.0001	4 µm	75 mm	4 mm	3 pieces
Superspher® 60 RP-select B	1.50975.0001	4 µm	125 mm	4 mm	1 piece
Superspher® 60 RP-select B	1.50973.0001	4 µm	250 mm	4 mm	1 piece

The LiChroCART® columns (75, 125, 150 and 250 mm length) in the list above (2, 3 and 4 mm i.d.) require part number 1.51486.0001 manu-CART® cartridge column holder, which can be used to hold one cartridge column with or without a 4–4 mm guard column. Additional dimensions available as customized packings see page 292. As guard column we recommend LiChroCART® 4–4 LiChrospher® guard cartridges.

LiChrospher®

Silica carrier for constant top-rate results

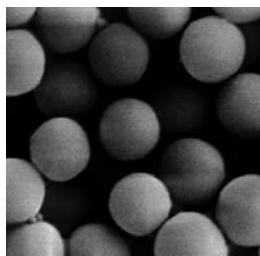

LiChrospher® is the name given to reliable and versatile traditionally produced spherical silica carriers. LiChrospher® silica carriers are available in a number of different modifications. The polar modified phases LiChrospher® CN, LiChrospher® NH₂ and LiChrospher® DIOL as well as LiChrospher® Si with no modification are best for normal-phase HPLC. Furthermore, LiChrospher® PAH is highly efficient and selective for the separation of PAH, as well as LiChrospher® WP 300 RP-18 for the separation of peptides and low molecular weight proteins.

LiChrospher® packing materials are available as Hibar® RT columns and as LiChroCART® cartridges of various lengths and internal diameters (10 mm, 4.6 mm, 4 mm, 3 mm and 2 mm). LiChroCART® 3 mm i.d. and 2 mm i.d. narrow bore cartridges for HPLC save costs by reducing solvent consumption and allow the handling of very small quantities with excellent sensitivity and resolution. LiChroCART® cartridges 4.6 mm, 4 mm i.d., 3 mm i.d. and 2 mm i.d. are compatible with manu-CART® "4". This facilitates faster and more flexible method adaptation to smaller bore columns. LiChroCART® cartridges 10 mm i.d. have to be used with manu-CART® "10".

Specifications of LiChrospher® packing materials

Packing material	Characteristics	Spec. surface area S _{BET} [m ² /g]	Pore volume V _p [mL/g]	Particle size d _p [μm]	% C	Surface coverage [μmol/m ²]
LiChrospher® Si 60	spherical particles of silica medium pore size: 6 nm (60 Å)	700	0.85	5, 10	–	–
LiChrospher® Si 100	spherical particles of silica medium pore size: 10 nm (100 Å)	400	1.25	5, 10	–	–
LiChrospher® 100 CN	spherical particles of silica with cyanopropyl function	350	1.25	5, 10	6.6	3.52
LiChrospher® 100 NH ₂	spherical particles of silica with aminopropyl function	350	1.25	5, 10	4.6	4.10
LiChrospher® 100 DIOL	spherical particles of silica with vicinal hydroxyl function on C-chains	350	1.25	5, 10	8.0	3.87
LiChrospher® 100 RP-8	spherical particles of silica with octyl derivative	350	1.25	5, 10	12.5	4.04
LiChrospher® 100 RP-8 endcapped	spherical particles of silica with octyl derivative endcapped	350	1.25	5, 10	13.0	4.44
LiChrospher® 100 RP-18	spherical particles of silica with octadecyl derivative	350	1.25	5, 10	21.0	3.61
LiChrospher® 100 RP-18 endcapped	spherical particles of silica with octadecyl derivative endcapped	350	1.25	5, 10	21.6	4.09
LiChrospher® 60 RP-select B	spherical particles of silica with octyl derivative, especially suitable for the RPseparation of basic compounds	350	0.9	5, 10	11.5	3.55
LiChrospher® WP 300 RP-18	spherical particles of silica with octadecyl derivative	80	1.0	5, 12, 15	–	–

Fraction range of LiChrospher® packing materials

Product	Spec. pore volume [mL/g]	Spec. surface area [m ² /g]	Fractionation range (Polystyrene/THF) [g/mol]
LiChrospher® Si 60	0.85	700	100 - 2 · 10 ⁴
LiChrospher® Si 100	1.25	400	200 - 7 · 10 ⁴
LiChrospher® 100 DIOL	1.25	350	200 - 4 · 10 ⁴
LiChrospher® 100 RP-18	1.25	350	200 - 4 · 10 ⁴
LiChrospher® WP 300 RP-18	1.0	80	4000 - 6 · 10 ⁵

Certified reproducibility of HPLC separations

The heart of each HPLC system is the column, where the separation of sample components takes place. Due to the chemical properties of silica, HPLC columns are subject to natural wear, e.g. due to the irreversible adsorption of injected samples or sample matrix or due to mechanical and chemical instabilities of the stationary phase. As a consequence, altered selectivities, "ghost peaks", diminished separation power or excessively elevated column pressures will result, preventing further column use. Hence, changing HPLC columns is a permanent process. This need not necessarily be problematic if the new column is one of the same type and has the same properties as the preceding one. The certified reproducibility of HPLC columns makes extensive method revision unnecessary and does away with additional costs.

Separation performance, selectivity and capacity

Reproducibility is the most important property of an HPLC column, independent of the respective production batch. All columns of the same type should be reproducible and therefore comparable in terms of separation performance, selectivity and retention behaviour. In its determination, a characteristic substance mixture is subjected to chromatography under buffered elution conditions. The resulting chromatographic parameters such as k-values, separation factors and the minimum number of theoretical plates are fixed.

- Retention factor k (previously designated as capacity factor k') of a neutral compound means: the defined hydrophobic character of the stationary phase.
- Separation factors α (i.e. relative retention times, previously designated as selectivity) bring about a defined order of elution and defined peak distance from batch to batch and cartridge to cartridge.
- Minimum number of theoretical plates (N) under buffered (not ideal) chromatographic conditions ensures separation performance.

Certified reproducibility of HPLC columns – no additional costs in method evaluation

The evaluation of quality control methods for certain products, e.g. in the pharmaceutical sector, constitutes a considerable cost factor. The fact that an analytical method once established is used in expensive registration procedures for many years (up to 10 and more) requires thorough and careful elaboration. In this context, the selection of the HPLC column is an important decision criterion. The column certificate places the highest demands on process control during the batch-to-batch production of column materials. This ensures the customer constant HPLC column quality over many years. Therefore, no additional costs will arise for the revision or re-registration of a particular analysis method.

LiChrospher® 100 RP-18 and RP-18 endcapped

LiChrospher® 100 RP-18 and LiChrospher® 100 RP-18 endcapped are reliable and versatile traditionally produced spherical silica carriers with reversed-phase properties. They are well suited for the chromatography of acidic, neutral and weakly basic compounds, substances found frequently in all analytical fields. For LiChrospher® RP-18, a masterbatch concept, where several individual batches are used to produce a large batch ("the masterbatch") of the LiChrospher® RP-18 sorbent, is used with the aim of eliminating the variation between the individual batches.

Specifications of LiChrospher® 100 RP-18 and RP-18 endcapped

	LiChrospher® 100 RP-18	LiChrospher® 100 RP-18 endcapped
Sorbent characteristics	Particles of silica with octadecyl derivative	Particles of silica with octadecyl derivative endcapped
Particle shape	spherical	spherical
Particle size	5; 10 µm	5; 10 µm
Pore size	100 Å (nm)	100 Å (nm)
Pore volume	1.25 mL/g	1.25 mL/g
Specific surface area	350 m ² /g	350 m ² /g
Carbon load	21.0% C	21.6% C
Coverage of the surface	3.61 µmol/m ²	4.09 µmol/m ²
Efficiency	55,000 N/m; 20,000 N/m	55,000 N/m; 20,000 N/m
pH range	pH 2-7.5	pH 2-7.5
Shipping eluent	Acetonitrile/Water	Acetonitrile/Water

Ordering information – LiChrospher® 100 RP-18 and RP-18e, stainless steel columns Hibar®

Product	Ordering No.	Particle size	Dimension length	Dimension i.d.	Contents of one package
LiChrospher® 100 RP-18	1.50545.0001	5 µm	100 mm	4.6 mm	1 piece
LiChrospher® 100 RP-18	1.50477.0001	5 µm	125 mm	4 mm	1 piece
LiChrospher® 100 RP-18	1.50546.0001	5 µm	150 mm	4.6 mm	1 piece
LiChrospher® 100 RP-18	1.50377.0001	5 µm	250 mm	4 mm	1 piece
LiChrospher® 100 RP-18	1.50547.0001	5 µm	250 mm	4.6 mm	1 piece
LiChrospher® 100 RP-18 endcapped	1.50548.0001	5 µm	100 mm	4.6 mm	1 piece
LiChrospher® 100 RP-18 endcapped	1.50549.0001	5 µm	150 mm	4.6 mm	1 piece
LiChrospher® 100 RP-18 endcapped	1.50550.0001	5 µm	250 mm	4.6 mm	1 piece

The Hibar® columns are complete with endfittings. When using a guard column with a Hibar® column, we recommend part number 1.51487.0001 guard column cartridge holder for 4–4 mm guard column cartridges LiChroCART®. Additional dimensions available as customized packings see page 292.

Ordering information – LiChrospher® 100 RP-18 and RP-18e, glass cartridges EcoCART®

Product	Ordering No.	Particle size	Dimension length	Dimension i.d.	Contents of one package
LiChrospher® 100 RP-18	1.51232.0001	5 µm	125 mm	3 mm	3 piece
LiChrospher® 100 RP-18 endcapped	1.51427.0001	5 µm	125 mm	3 mm	3 pieces

EcoCART® glass cartridges require part number 1.51207.0001 EcoCART® glass cartridge holder. Additional dimensions and validation kit available as customized packings see page 292.

► **Purospher® STAR RP-8 endcapped** Optimized for more polar compounds
page 236

► **Purospher® RP-18 endcapped** Excellent peak symmetry with either basic or strongly acidic compounds
page 240

► **Purospher® RP-18** Accelerate and simplify method development for basic compounds
page 242

► **Superspher®** Silica carrier for highly efficient separations
page 246

► **LiChrospher®** Silica carrier for constant top-rate results
page 250

► **LiChrosorb®** Irregular shaped silica sorbent
page 272

► **Customized packings** Always the right column
page 292

Accessories for particulate HPLC columns:

► **manu-CART® cartridge holder** for LiChroCART® cartridges
page 296

► **LiChroCART® cartridge** Different lengths, different internal diameter
page 299

Ordering information – LiChrospher® 100 RP-18 and RP-18 endcapped,
stainless steel cartridges LiChroCART®

Product	Ordering No.	Particle size	Dimension length	Dimension i.d.	Contents of one package
LiChrospher® 100 RP-18	1.50957.0001	5 µm	4 mm	4 mm	10 pieces
LiChrospher® 100 RP-18	1.50931.0001	5 µm	25 mm	4 mm	3 pieces
LiChrospher® 100 RP-18	1.50987.0001	5 µm	75 mm	4 mm	3 pieces
LiChrospher® 100 RP-18	1.50600.0001	5 µm	100 mm	4.6 mm	1 piece
LiChrospher® 100 RP-18	1.50159.0001	5 µm	125 mm	3 mm	1 piece
LiChrospher® 100 RP-18	1.50823.0001	5 µm	125 mm	4 mm	1 piece
LiChrospher® 100 RP-18	1.50943.0001	5 µm	125 mm	4 mm	3 pieces
LiChrospher® 100 RP-18	1.50601.0001	5 µm	150 mm	4.6 mm	1 piece
LiChrospher® 100 RP-18	1.50154.0001	5 µm	250 mm	3 mm	1 piece
LiChrospher® 100 RP-18	1.50833.0001	5 µm	250 mm	4 mm	1 piece
LiChrospher® 100 RP-18	1.50983.0001	5 µm	250 mm	4 mm	3 pieces
LiChrospher® 100 RP-18	1.50602.0001	5 µm	250 mm	4.6 mm	1 piece
LiChrospher® 100 RP-18	1.50843.0001	10 µm	250 mm	4 mm	1 piece
LiChrospher® 100 RP-18	1.50853.0001	10 µm	250 mm	10 mm	1 piece
LiChrospher® 100 RP-18 endcapped	1.50962.0001	5 µm	4 mm	4 mm	10 pieces
LiChrospher® 100 RP-18 endcapped	1.50936.0001	5 µm	25 mm	4 mm	3 pieces
LiChrospher® 100 RP-18 endcapped	1.50603.0001	5 µm	100 mm	4.6 mm	1 piece
LiChrospher® 100 RP-18 endcapped	1.50828.0001	5 µm	125 mm	4 mm	1 piece
LiChrospher® 100 RP-18 endcapped	1.50734.0001	5 µm	125 mm	4 mm	3 pieces
LiChrospher® 100 RP-18 endcapped	1.50604.0001	5 µm	150 mm	4.6 mm	1 piece
LiChrospher® 100 RP-18 endcapped	1.50838.0001	5 µm	250 mm	4 mm	1 piece
LiChrospher® 100 RP-18 endcapped	1.50995.0001	5 µm	250 mm	4 mm	3 pieces
LiChrospher® 100 RP-18 endcapped	1.50605.0001	5 µm	250 mm	4.6 mm	1 piece
LiChrospher® 100 RP-18 endcapped	1.50848.0001	10 µm	250 mm	4 mm	1 piece
LiChrospher® 100 RP-18 endcapped	1.50858.0001	10 µm	250 mm	10 mm	1 piece

The LiChroCART® columns (75, 125, 150 and 250 mm length) in the list above (3 and 4 mm i.d.) require part number 1.51486.0001 manu-CART® cartridge column holder, which can be used to hold one cartridge column with or without a 4–4 mm guard column. LiChroCART® columns 250–10 mm require part number 1.51419.0001 manu-CART® 10. Additional dimensions and validation kit available as customized packings see page 292.

Ordering information – LiChrospher® 100 RP-18 and RP-18 endcapped sorbents

Product	Ordering No.	Particle size	Package	Quantity
LiChrospher® 100 RP-18	1.16177.0010	5 µm	Glass	10 g
LiChrospher® 100 RP-18	1.16105.0010	10 µm	Glass	10 g
LiChrospher® 100 RP-18 endcapped	1.19637.0010	5 µm	Glass	10 g
LiChrospher® 100 RP-18 endcapped	1.19633.0010	10 µm	Glass	10 g

Separation examples on LiChrospher® 100 RP-18

Pharmaceutical analysis: Acetyl salicylic acid

Column	LiChroCART® 250-4 LiChrospher® 100 RP-18, 5 µm
Mobile phase	0.01 mol/L sodiumdihydrogenphosphate pH 2.0 with phosphoric acid/Acetonitrile/ Methanol 70/25/5 (v/v/v)
Flow rate	1.0 mL/min
Detection	UV 237 nm
Temperature	Room temperature
Injection volume	100 µL
Sample	1. Acetylsalicylic acid 2. Salicylic acid 3. p-Hydroxybenzoic acid ethyl ester (internal standard)

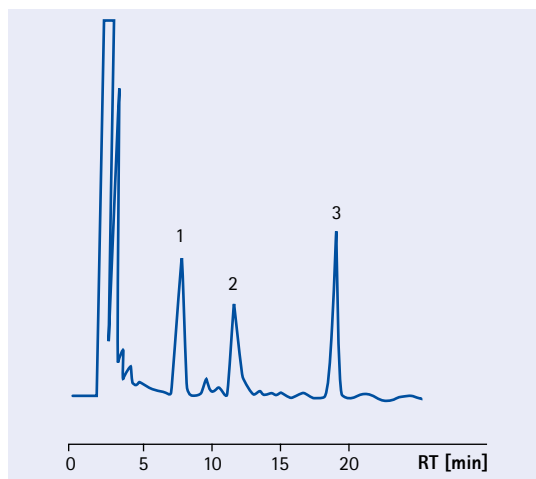

Pharmaceutical analysis: 2-Oxoacids

Column	LiChroCART® 250-4 LiChrospher® 100 RP-18, 5 µm
Mobile phase	Methanol/Water/Acetonitrile 35/45/20 (v/v/v)
Flow rate	1.0 mL/min
Detection	Fluorescence Ex 350 nm, Em 410 nm
Temperature	Room temperature
Injection volume	100 µL
Sample	1. Pyruvate 2. - 3. 2-Oxobutyric acid 4. 2-Oxoisovaleric acid (from valine) 5. 2-Oxoisocaproic acid (from leucine) 6. 2-Oxocaproic acid (internal standard) 7. 2-Oxo-3-methyl valeric acid (from isoleucine)

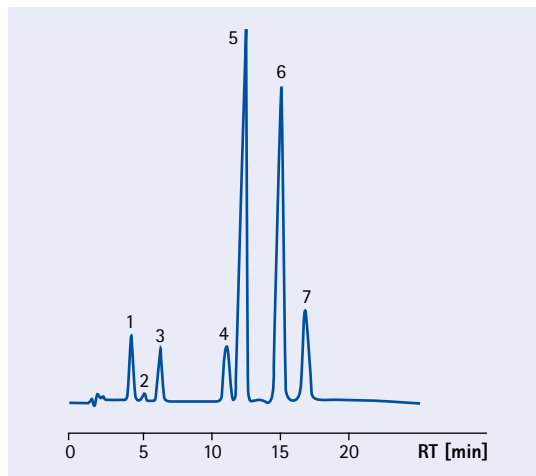

Pharmaceutical analysis: Corticoids

Column	LiChroCART® 125-4 LiChrospher® 100 RP-18, 5 µm
Mobile phase	Acetonitrile/0.5 mmol/L sodium acetate buffer 30/70 (v/v)
Flow rate	0.8 mL/min
Detection	UV 235 nm
Temperature	Room temperature
Injection volume	100 µL
Sample	1. Prednisolone 2. Cortisone 3. Dexamethasone 4. Prednisolone acetate 5. Hydrocortisone acetate 6. Cortisone acetate

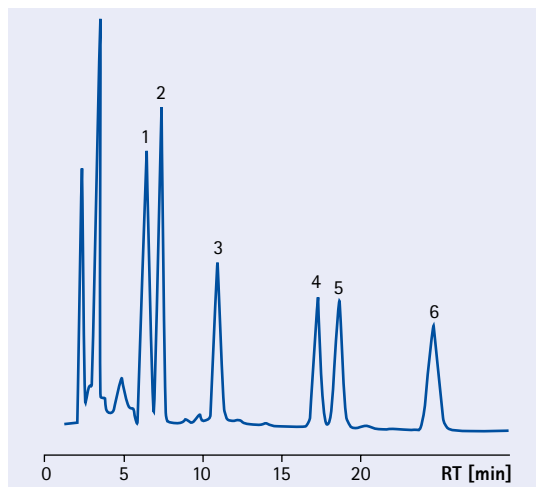

Separation examples on LiChrospher® 100 RP-18

Environmental analysis: Explosives

Column	LiChroCART® 250-3 LiChrospher® 100 RP-18, 5 µm	
Mobile phase	A: Methanol B: Water	
Gradient	0 min	26% A
	25 min	48% A
	55 min	48% A
Flow rate	0.4 mL/min	
Detection	Diode array detection 200-320 nm Spectral band with 4 nm	
Temperature	32°C	
Injection volume	50 µL	
Sample	1. Octogene 2. Hexogene 3. 2-Amino-6-nitotoluene 4. 4-Amino-2-nitrotoluene 5. 1,3-Dinitrotoluene 6. Nitrobenzene 7. Trinitrobenzene 8. 4-Amino-2,6-dinitrotoluene 9. 2-Amino-4,6-dinitrotoluene 10. 3,4-Dinitrotoluene 11. 2,6-Dinitrotoluene 12. 2,4-Dinitrotoluene 13. 2-Nitrotoluene 14. 4-Nitrotoluene	

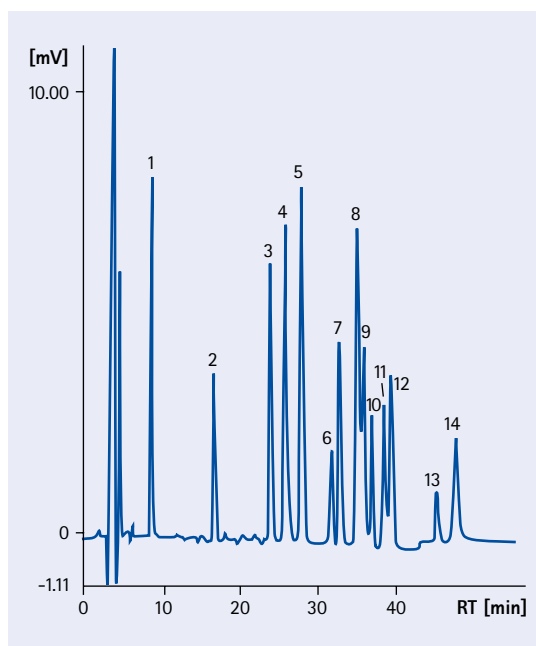

Environmental analysis: Naphthols, chlorophenol and nitro-aromatics in water

Column	LiChroCART® 250-4 LiChrospher® 100 RP-18, 5 µm	
Mobile phase	Acetonitrile/Water 40/60 (v/v)	
Flow rate	1.0 mL/min	
Detection	Diode array detector min / 233 nm	
	15.70 min	263 nm
	18.75 min	270 nm
Temperature	Room temperature	
Injection volume	100 µL	
Sample	1. 2-Naphthol 2. 1-Naphthol 3. 2,4-Dichlorophenol 4. 2,4-Dinitrotoluene 5. 2-Nitrotoluene 6. 4-Nitrotoluene 7. 2-Nitrotoluene	

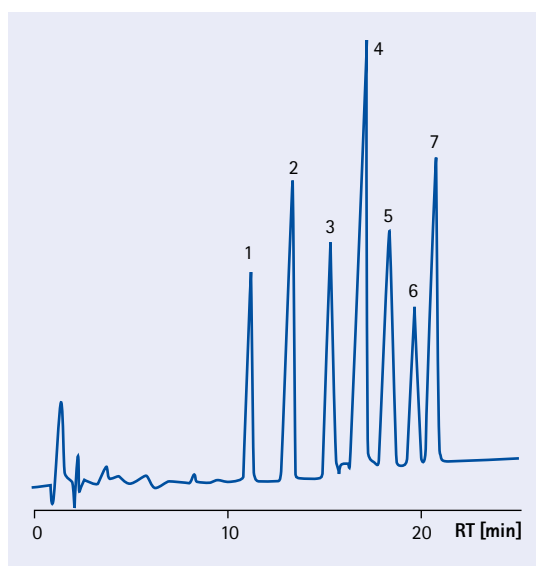

LiChrospher® WP 300 RP-18

High-resolution separations of peptides and tRNA molecules

LiChrospher® WP 300 RP-18 is a highly selective and reliable HPLC column for the separation of peptides and low molecular weight proteins. LiChrospher® WP 300 RP-18 enables the tailing-free separation of basic compounds and is excellently suited for the separation of tRNA molecules. High recovery rates are achieved, especially in the case of highly hydrophobic peptides.

Specifications of LiChrospher® WP 300 RP-18

Sorbent characteristics	Particles of silica with octadecyl derivative
Particle shape	spherical
Particle size	5, 12, 15 µm
Pore size	300 Å (30 nm)
Specific surface area	80 m ² /g
pH range	pH 2.0 - 7.5
Shipping eluent	Acetonitrile/Water

Ordering information – LiChrospher® WP 300 RP-18, stainless steel cartridges LiChroCART®

Product	Ordering No.	Particle size	Dimension length	Dimension i.d.	Contents of one package
LiChrospher® WP 300 RP-18	1.50140.0001	5 µm	4 mm	4 mm	10 pieces
LiChrospher® WP 300 RP-18	1.50137.0001	5 µm	250 mm	4 mm	1 piece

The LiChroCART® columns in the list above require part number 1.51486.0001 manu-CART® cartridge column holder, which can be used to hold one cartridge column with or without a 4-4 mm guard column. Additional dimensions available as customized packings see page 292.

► **LiChrospher®**
Silica carrier for constant top-rate results
page 250

► **Customized packings**
Always the right column
page 292

Accessories for particulate HPLC columns:

► **manu-CART® cartridge holder** for LiChroCART® cartridges
page 296

► **LiChroCART® cartridge**
Different lengths, different internal diameter
page 299

Separation examples on LiChrospher® WP 300 RP-18

Angiotensin I and II

Column	LiChroCART® 250-4 LiChrospher® WP 300 RP-18, 5 µm
Mobile phase	A: Water + 0.1% TFA B: Acetonitrile + 0.1% TFA
Gradient	20 min 20% B - 60% B
Flow rate	0.6 mL/min
Detection	UV 214
Temperatur	Room temperature
Injection volume	100 µL
Sample	1. Angiotensin II (human) 2. Angiotensin I (human) each 1 mg/mL

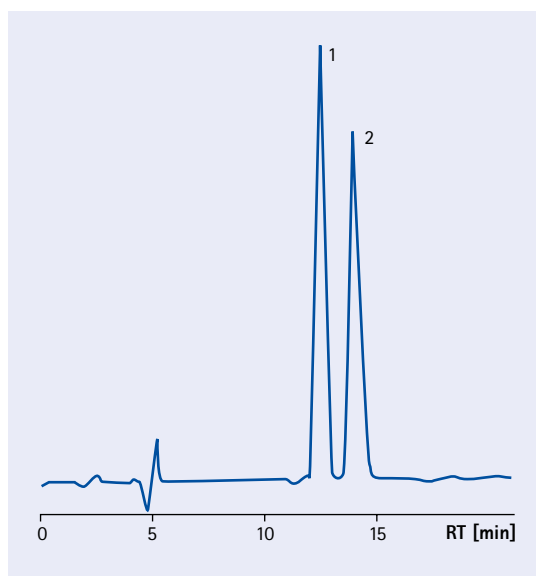

Poly-L-lysine peptides

Column	LiChroCART® 250-4 LiChrospher® WP 300 RP-18, 5 µm
Mobile phase	A: Water + 0.2% TFA B: Acetonitrile + 0.2% TFA
Gradient	60 min 0% B - 100% B
Flow rate	0.7 mL/min
Detection	UV 214
Temperatur	Room temperature
Injection volume	100 µL
Sample	Poly-L-lysine hydrobromide Molecular weight 1000 - 4000 Dalton

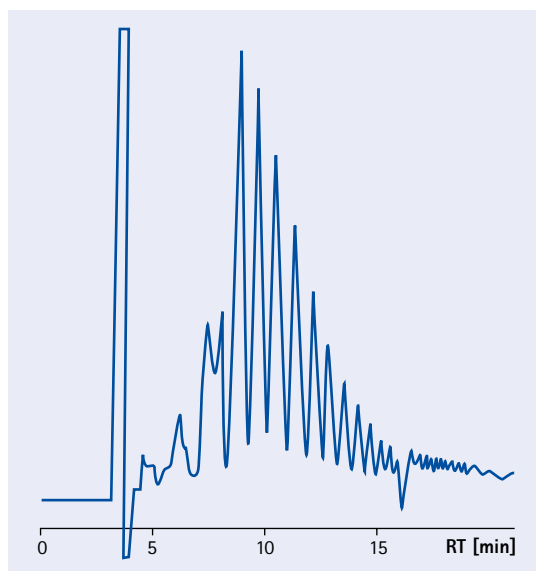

LiChrospher® PAH

Indispensable in PAH trace analysis

LiChrospher® PAH is a highly efficient and selective HPLC column especially designed for the high-resolution separation of 16 PAH (polycyclic aromatic hydrocarbons) according to EPA 610 and 550 + benzo(e)pyrene + perylene.

Polycyclic aromatic hydrocarbons (PAH) originate from organic material through pyrolysis or incomplete combustion. The main sources are the exhaust fumes of private and industrial furnaces, car exhaust and tobacco smoke. Since some PAH are carcinogenic, their determination is of great importance.

LiChrospher® PAH is based on an RP-18 silica gel special modified to achieve highly resolved PAH separations.

LiChrospher® PAH can be used for both the isocratic separation of 6 PAH according to the German DIN draft method and the gradient separation of 16 PAH according to EPA + benzo(e)pyrene + perylene.

LiChrospher® PAH produces excellent results for the separation of 16 PAH (EPA 610) + benzo(e)pyrene + perylene:

- baseline separation at 25° or 20°C by gradient HPLC (esp.: benzo(e)pyrene, benzo(b)fluoranthene and perylene)
- programmed fluorescence detection
- first-eluting PAH (naphthalene) at approx. 10 minutes
- separation within 30 minutes
- simple eluents and gradients

Specifications of LiChrospher® PAH

Sorbent characteristic	Particles of silica with octadecyl derivative
Particle shape	spherical
Particle size	5 µm
Pore size	150 Å (15 nm)
Specific surface area	200 m ² /g
Carbon load	20%
pH range	pH 2 - 7.5
Shipping eluent	Acetonitrile/Water

Ordering information – LiChrospher® PAH

Packing material	Ordering No.	Particle size	Dimension Length	Dimension i.d.	Contents of one package
LiChrospher® PAH	1.50156.0001	5 µm	250 mm	3 mm	1 piece
LiChrospher® PAH	1.50148.0001	5 µm	4 mm	4 mm	10 pieces
LiChrospher® PAH	1.50149.0001	5 µm	250 mm	4 mm	1 piece

The LiChroCART® columns (75, 125, 150 and 250 mm length) in the list above (3 and 4 mm i.d.) require part number 1.51486.0001 manu-CART® cartridge column holder, which can be used to hold one cartridge column with or without a 4–4 mm guard column.

Accessories for particulate HPLC columns:

► manu-CART® cartridge holder for LiChroCART® cartridges

page 296

► LiChroCART® cartridge
Different lengths, different internal diameter

page 299

Separation examples on LiChrospher® PAH

16 PAH acc. to EPA 610/550 + benzo(e)pyrene + perylene by UV detection

Column	LiChroCART® 250-3 LiChrospher® PAH, 5 µm	
Mobile phase	A: Acetonitrile B: Water	
Gradient	0 - 3 min	50% A
	3 - 10 min	50% A - 100% A
	10 - 45 min	100% A
Flow rate	0.56 mL/min	
Detection	UV 254	
Temperature	20°C	
Injection volume	20 µL	

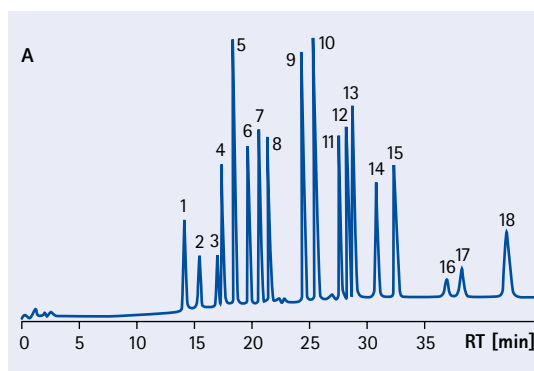

16 PAH acc. to EPA 610/550 + benzo(e)pyrene + perylene by fluorescence detection

Column	LiChroCART® 250-4 LiChrospher® PAH, 5 µm		
Mobile phase	A: Acetonitrile B: Water		
Gradient	0 - 3 min	60% A	
	3 - 15 min	60% A - 100% A	
	15 - 50 min	100% A	
Flow rate	Flow rate 1.0 mL/min		
Detection	Peak No.	Ex [nm]	Em [nm]
[programmed	1, 3, 4	280	330
fluorescence	5	246	370
detection]	6	250	406
	7	280	450
	8	270	390
	9, 10	265	380
	11 - 15	290	430
	16, 17	290	410
	18	300	500
Temperature	20°C		
Injection volume	10 µL		

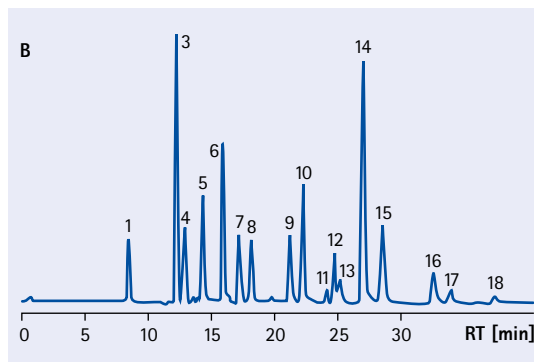

Sample	A [µg/mL]	B [ng/mL]
1. Naphthalene	2.00	100.0
2. Acenaphthylene	1.54	n.n.
3. Acenaphthene	2.06	103.0
4. Fluorene	0.48	24.0
5. Phenanthrene	0.35	17.5
6. Anthracene	0.08	4.0
7. Fluoranthene	0.77	4.0
8. Pyrene	0.85	42.5
9. Benzo(a)anthracene	0.41	20.5
10. Chrysene	0.37	18.5
11. Benzo(e)pyrene	1.00	37.0
12. Benzo(b)fluoranthene	0.42	21.0
13. Perylene	1.00	36.0
14. Benzo(k)fluoranthene	0.42	23.5
15. Benzo(a)pyrene	0.49	24.5
16. Dibenzo(a,h)anthracene	0.36	18.0
17. Benzo(g,h,i)perylene	0.37	18.5
18. Ideno(1,2,3-c,d)pyrene	0.43	21.5

Separation examples on LiChrospher® PAH

6 PAH acc. to EU-proposal ISO/CD 7981 + perylene by UV detection

Column	LiChroCART® 250-3 LiChrospher® PAH, 5 µm	
Mobile phase	Acetonitrile	
Flow rate	1.0 mL/min	
Detection	UV 254	
Temperature	25°C	
Injection volume	30 µL	
Sample	1. Fluoranthene	1.04 µg/mL
	2. Benzo(b)fluoranthene	0.68 µg/mL
	3. Perylene	0.72 µg/mL
	4. Benzo(k)fluoranthene	0.65 µg/mL
	5. Benzo(a)pyrene	0.60 µg/mL
	6. Benzo(g,h,i)perylene	0.65 µg/mL
	7. Ideno(1,2,3-c,d)pyrene	0.58 µg/mL

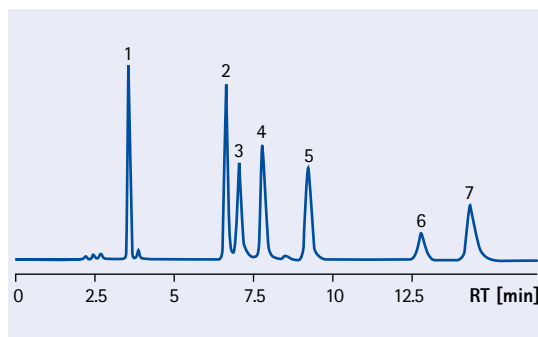

LiChrospher® 100 RP-8 and RP-8 endcapped

For reproducible reversed phase separation

LiChrospher® 100 RP-8 and LiChrospher® 100 RP-8 endcapped are reliable and versatile traditionally produced spherical silica carriers with reversed-phase properties. They are well suited for the chromatography of acidic, neutral and weakly basic compounds, substances found frequently in all analytical fields. Their good column selectivity and performance ensure that these parameters remain constant from batch to batch and from year to year.

Specifications of LiChrospher® 100 RP-8 and RP-8 endcapped

	LiChrospher® 100 RP-8	LiChrospher® 100 RP-8 endcapped
Sorbent characteristics	Particles of silica with octyl derivative	Particles of silica with octyl derivative endcapped
Particle shape	spherical	spherical
Particle size	5; 10 µm	5; 10 µm
Pore size	100 Å (10 nm)	100 Å (10 nm)
Pore volume	1.25 mL/g	1.25 mL/g
Specific surface area	350 m ² /g	350 m ² /g
Carbon load	12.5% C	13.0% C
Coverage of the surface	4.04 µmol/m ²	4.44 µmol/m ²
Efficiency	55,000 N/m; 25,000 N/m	55,000 N/m; 25,000 N/m
pH range	pH 2-7.5	pH 2-7.5
Shipping eluent	Acetonitrile/Water	Acetonitrile/Water

Ordering information – LiChrospher® 100 RP-8 and RP-8 endcapped sorbents

Product	Ordering No.	Particle size	Package	Quantity
LiChrospher® 100 RP-8	1.16129.0010	5 µm	Glass	10 g
LiChrospher® 100 RP-8	1.16139.0010	10 µm	Glass	10 g
LiChrospher® 100 RP-8 endcapped	1.19636.0010	5 µm	Glass	10 g
LiChrospher® 100 RP-8 endcapped	1.19632.0010	10 µm	Glass	10 g

► **Purospher® STAR RP-8 endcapped** Optimized for more polar compounds
page 236

► **Purospher® RP-18 endcapped** Excellent peak symmetry with either basic or strongly acidic compounds
page 240

► **Purospher® RP-18** Accelerate and simplify method development for basic compounds
page 242

► **Superspher®** Silica carrier for highly efficient separations
page 246

► **LiChrosorb®** Irregular shaped silica sorbent
page 272

► **Customized packings** Always the right column
page 292

Accessories for particulate HPLC columns:

► **manu-CART® cartridge holder** for LiChroCART® cartridges
page 296

► **LiChroCART® cartridge** Different lengths, different internal diameter
page 299

Ordering information – LiChrospher® 100 RP-8 and RP-8 endcapped, stainless steel cartridges LiChroCART®

Product	Ordering No.	Particle size	Dimension length	Dimension i.d.	Contents of one package
LiChrospher® 100 RP-8	1.50956.0001	5 µm	4 mm	4 mm	10 pieces
LiChrospher® 100 RP-8	1.50930.0001	5 µm	25 mm	4 mm	3 pieces
LiChrospher® 100 RP-8	1.50986.0001	5 µm	75 mm	4 mm	3 pieces
LiChrospher® 100 RP-8	1.50634.0001	5 µm	100 mm	4.6 mm	1 piece
LiChrospher® 100 RP-8	1.50822.0001	5 µm	125 mm	4 mm	1 piece
LiChrospher® 100 RP-8	1.50942.0001	5 µm	125 mm	4 mm	3 pieces
LiChrospher® 100 RP-8	1.50635.0001	5 µm	150 mm	4.6 mm	1 piece
LiChrospher® 100 RP-8	1.50832.0001	5 µm	250 mm	4 mm	1 piece
LiChrospher® 100 RP-8	1.50982.0001	5 µm	250 mm	4 mm	3 pieces
LiChrospher® 100 RP-8	1.50636.0001	5 µm	250 mm	4.6 mm	1 piece
LiChrospher® 100 RP-8	1.50842.0001	10 µm	250 mm	4 mm	1 piece
LiChrospher® 100 RP-8	1.50945.0001	10 µm	10 mm	10 mm	2 pieces
LiChrospher® 100 RP-8 endcapped	1.50961.0001	5 µm	4 mm	4 mm	10 pieces
LiChrospher® 100 RP-8 endcapped	1.50637.0001	5 µm	100 mm	4.6 mm	1 piece
LiChrospher® 100 RP-8 endcapped	1.50827.0001	5 µm	125 mm	4 mm	1 piece
LiChrospher® 100 RP-8 endcapped	1.50638.0001	5 µm	150 mm	4.6 mm	1 piece
LiChrospher® 100 RP-8 endcapped	1.50837.0001	5 µm	250 mm	4 mm	1 piece
LiChrospher® 100 RP-8 endcapped	1.50639.0001	5 µm	250 mm	4.6 mm	1 piece
LiChrospher® 100 RP-8 endcapped	1.50847.0001	10 µm	250 mm	4 mm	1 piece

The LiChroCART® columns (75, 125, 150 and 250 mm length) in the list above (4 mm i.d.) require part number 1.51486.0001 manu-CART® cartridge column holder, which can be used to hold one cartridge column with or without a 4–4 mm guard column. LiChroCART® columns 250–10 mm require part number 1.51419.0001 manu-CART® 10. Additional dimensions available as customized packings see page 292.

Ordering information – LiChrospher® 100 RP-8 and RP-8 endcapped, stainless steel columns Hibar®

Product	Ordering No.	Particle size	Dimension length	Dimension i.d.	Contents of one package
LiChrospher® 100 RP-8	1.50578.0001	5 µm	100 mm	4.6 mm	1 piece
LiChrospher® 100 RP-8	1.50579.0001	5 µm	150 mm	4.6 mm	1 piece
LiChrospher® 100 RP-8	1.50329.0001	5 µm	250 mm	4 mm	1 piece
LiChrospher® 100 RP-8	1.50580.0001	5 µm	250 mm	4.6 mm	1 piece
LiChrospher® 100 RP-8 endcapped	1.50581.0001	5 µm	100 mm	4.6 mm	1 piece
LiChrospher® 100 RP-8 endcapped	1.50582.0001	5 µm	150 mm	4.6 mm	1 piece
LiChrospher® 100 RP-8 endcapped	1.50583.0001	5 µm	250 mm	4.6 mm	1 piece

The Hibar® columns are complete with endfittings. When using a guard column with a Hibar® column, we recommend part number 1.51487.0001 guard column cartridge holder for 4–4 mm guard column cartridges LiChroCART®. Additional dimensions available as customized packings see page 292.

Separation examples on LiChrospher® 100 RP-8

Nucleotides

Column	LiChrospher® 100 RP-8, 5 µm
Mobile phase	Acetonitrile/0.05 M phosphate buffer pH 6.5 90/10 (v/v) + 0.001 mol/L TBAHSO ₄
Flow rate	1.5 mL/min
Detection	UV 254 nm
Sample	1. NAD 2. Adenosine 3. NADH 4. NADPH

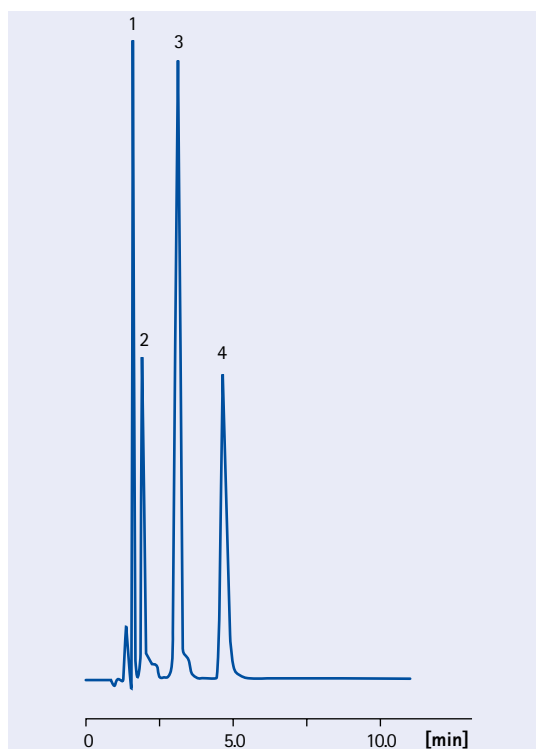

Digitalis

Column	LiChrospher® 100 RP-8, 5 µm
Mobile phase	Acetonitrile/0.05 M phosphate buffer pH 3.5 32/68 (v/v)
Flow rate	1.5 mL/min
Detection	UV 254 nm
Sample	1. Digoxigenine 2. Lanatosid C 3. Digoxine 4. Gitoxigenine 5. Digitoxigenine

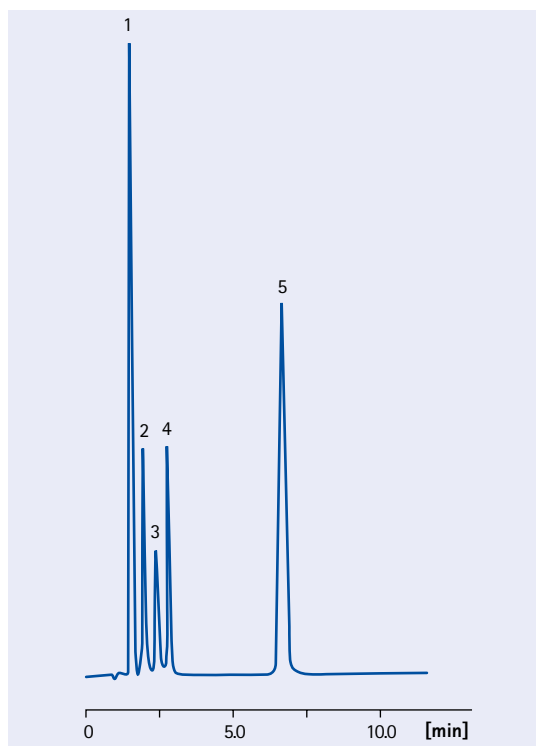

LiChrospher® 60 RP-select B

Excellent separations even with basic compounds

LiChrospher® RP-select B is a versatile reversed-phase sorbent based on spherical silica particles with excellent properties for the determination of basic substances, but with still good properties for the determination of neutral and acidic substances. **LiChrospher® 60 RP-select B is optimized in order to prevent any secondary interactions with basic substances and ensures that basic compounds are eluted as symmetrical substance peaks.**

Highest reliability of your HPLC results

The basis for the success of your HPLC analysis is the safety of an HPLC method that provides highly reproducible results. LiChrospher® RP-select B meets your challenging demands regarding excellent batch-to-batch reproducibility of an HPLC sorbent. A masterbatch concept, where several individual batches are used to produce a large batch ("the masterbatch") of the LiChrospher® RP-select B sorbent, is used with the aim of eliminating the variations between the different individual batches.



Specifications of LiChrospher® 60 RP-select B

Sorbent characteristics	Particles of silica with octyl derivative
Particle shape	spherical
Particle size	5; 10 µm
Pore size	60 Å (6 nm)
Pore volume	0.9 mL/g
Specific surface area	360 m ² /g
Carbon load	11.5% C
Coverage of the surface	3.55 µmol/m ²
Efficiency	55,000 N/m; 25,000 N/m
pH range	pH 2-7.5
Shipping eluent	Acetonitrile/Water

► **Purospher® STAR RP-8 endcapped** Optimized for more polar compounds
page 236

► **Purospher® RP-18 endcapped** Excellent peak symmetry with either basic or strongly acidic compounds
page 240

► **Purospher® RP-18** Accelerate and simplify method development for basic compounds
page 242

► **Superspher®** Silica carrier for highly efficient separations
page 246

► **LiChrospher®** Silica carrier for constant top-rate results
page 250

► **LiChrosorb®** Irregular shaped silica sorbent
page 272

► **Customized packings** Always the right column
page 292

Accessories for particulate HPLC columns:

► **manu-CART® cartridge holder** for LiChroCART® cartridges
page 296

► **LiChroCART® cartridge** Different lengths, different internal diameter
page 299

Ordering information – LiChrospher® 60 RP-select B sorbents

Product	Ordering No.	Particle size	Package	Quantity
LiChrospher® 60 RP-select B	1.19641.0010	5 µm	Glass	10 g
LiChrospher® 60 RP-select B	1.19642.0010	10 µm	Glass	10 g
LiChrospher® 60 RP-select B	1.19642.0100	10 µm	Glass	100 g

Ordering information – LiChrospher® 60 RP-select B, stainless steel cartridges LiChroCART®

Product	Ordering No.	Particle size	Dimension length	Dimension i.d.	Contents of one package
LiChrospher® 60 RP-select B	1.50963.0001	5 µm	4 mm	4 mm	10 pieces
LiChrospher® 60 RP-select B	1.50937.0001	5 µm	25 mm	4 mm	3 pieces
LiChrospher® 60 RP-select B	1.50993.0001	5 µm	75 mm	4 mm	3 pieces
LiChrospher® 60 RP-select B	1.50640.0001	5 µm	100 mm	4.6 mm	1 piece
LiChrospher® 60 RP-select B	1.50158.0001	5 µm	125 mm	3 mm	1 piece
LiChrospher® 60 RP-select B	1.50829.0001	5 µm	125 mm	4 mm	1 piece
LiChrospher® 60 RP-select B	1.50981.0001	5 µm	125 mm	4 mm	3 pieces
LiChrospher® 60 RP-select B	1.50641.0001	5 µm	150 mm	4.6 mm	1 piece
LiChrospher® 60 RP-select B	1.50155.0001	5 µm	250 mm	3 mm	1 piece
LiChrospher® 60 RP-select B	1.50839.0001	5 µm	250 mm	4 mm	1 piece
LiChrospher® 60 RP-select B	1.50984.0001	5 µm	250 mm	4 mm	3 pieces
LiChrospher® 60 RP-select B	1.50642.0001	5 µm	250 mm	4.6 mm	1 piece
LiChrospher® 60 RP-select B	1.50742.0001	10 µm	250 mm	4 mm	1 piece

The LiChroCART® columns (75, 125, 150 and 250 mm length) in the list above (3 and 4 mm i.d.) require part number 1.51486.0001, manu-CART® cartridge column holder, which can be used to hold one cartridge column with or without a 4–4 mm guard column. Additional dimensions and validation kit available as customized packings see page 292.

Ordering information – LiChrospher® 60 RP-select B, stainless steel columns Hibar®

Product	Ordering No.	Particle size	Dimension length	Dimension i.d.	Contents of one package
LiChrospher® 60 RP-select B	1.50573.0001	5 µm	100 mm	4.6 mm	1 piece
LiChrospher® 60 RP-select B	1.50574.0001	5 µm	150 mm	4.6 mm	1 piece
LiChrospher® 60 RP-select B	1.50575.0001	5 µm	250 mm	4.6 mm	1 piece

The Hibar® columns are complete with endfittings. When using a guard column with a Hibar® column, we recommend part number 1.51487.0001 guard column cartridge holder for 4–4 mm guard column cartridges LiChroCART®. Additional dimensions available as customized packings see page 292.

Ordering information – LiChrospher® 60 RP-select B, glass cartridges EcoCART®

Product	Ordering No.	Particle size	Dimension length	Dimension i.d.	Contents of one package
LiChrospher® 60 RP-select B	1.51233.0001	5 µm	125 mm	3 mm	3 pieces

Additional dimensions available as customized packings see page 292.

Separation examples on LiChrospher® 60 RP-select B

Environmental analysis: Phenols

Column	LiChroCART® 250-4 LiChrospher® 60 RP-select B, 5 µm	
Mobile phase	A: Water LiChrosolv® + 1% Acetic acid (96%) B: Acetonitrile LiChrosolv® + 1% Acetic acid (96%)	
Gradient	0 - 10 min	30% B
	10 - 28 min	30 - 80% B
	28 - 29 min	80 - 30% B
	29 - 35 min	30% B
Flow rate	1.0 mL/min	
Detection	Diode array	Detector
	0.0 min	362 nm
	6.0 min	273 nm
	8.5 min	319 nm
	11.0 min	278 nm
	16.0 min	283 nm
	19.5 min	269 nm
	22.0 min	293 nm
	25.0 min	304 nm
Temperature	30°C	
Injection volume	100 µL	
Sample	1. Picric acid	7. 2,4-Dimethylphenol
	2. Phenol	8. 4-Chloro-3-methylphenol
	3. 4-Nitrophenol	phenol
	4. 2-Chlorophenol	9. 2-Methyl-4,6-dinitrophenol
	5. 2,4-Dinitrophenol	phenol
	6. 2-Nitrophenol	10. 2,4,6-Trichlorophenol
		11. Pentachlorophenol

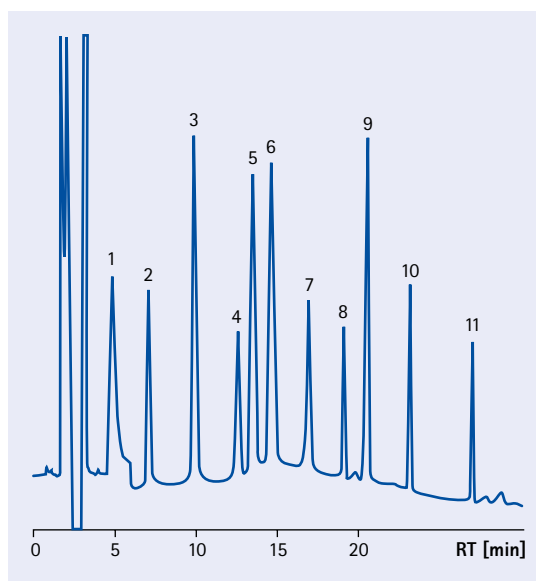

Environmental analysis: Fungicides in wine

Column	LiChroCART® 125-4 LiChrospher® 60 RP-select B, 5 µm
Mobile phase	Acetonitrile/Water 45/55 (v/v)
Flow rate	0.8 mL/min
Detection	UV 215
Temperature	Room temperature
Injection volume	50 µL
Sample	1. Iprodione 2. Procymidone 3. Vinclozoline

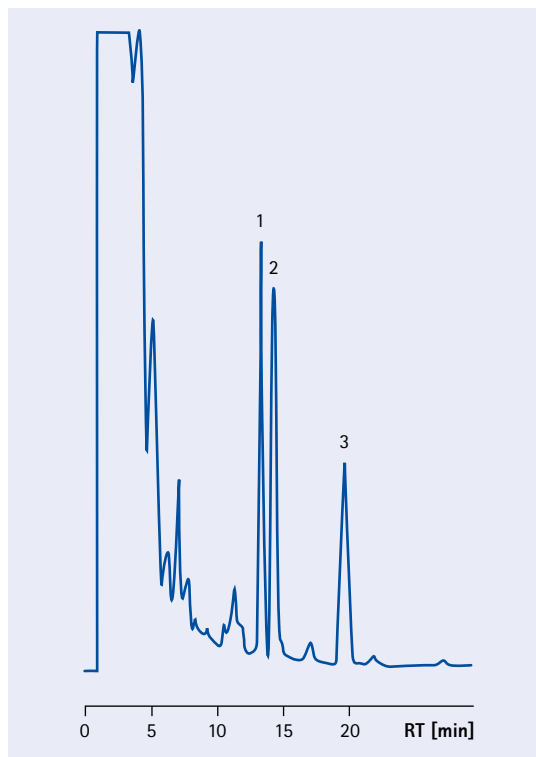

Alkaloids

Column	LiChroCART® 250-4 LiChrospher® 60 RP-select B, 5 µm
Mobile phase	A: 0.05 mol/L KH ₂ PO B: Methanol
Gradient	0 - 35 min 90% A - 55% A 35 - 40 min 55% A - 40% A 40 - 60 min 40% A 60 - 70 min 40% A - 25% A 70 - 80 min 25% A - 20% A
Flow rate	0.7 mL/min
Detection	UV 285
Temperature	Room temperature
Injection volume	20 µL
Sample	1. α-Homochelidonine 2. Chelidonine 3. Protopine 4. Allocryptopine 5. Stylopine 6. Coptisine 7. Berberine 8. Sanguinarine 9. Chelerythrine

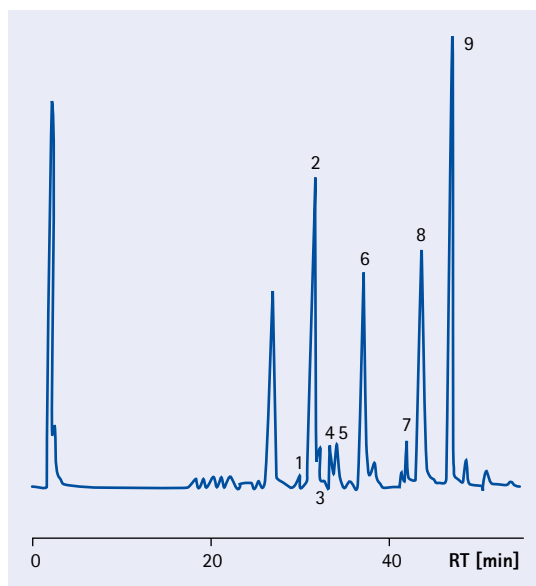

LiChrospher® 100 CN

Excellent for complex samples with polar and hydrophobic characteristics

LiChrospher® 100 CN has both polar and hydrophobic properties, thus can be used as a less polar alternative to LiChrospher® Si 60 in normal phase applications or as a less hydrophobic alternative to LiChrospher® RP-8 in reversed-phase applications. The combination of weak hydrophobic interactions and polar interactions enables successful separations of complex samples. In addition, the possibility of selective charged interactions makes it even more versatile.

Specifications of LiChrospher® 100 CN

Sorbent characteristics	Particles of silica with g-Cyanopropyl function
Particle shape	spherical
Particle size	5; 10 µm
Pore size	100 Å (10 nm)
Pore volume	1.25 mL/g
Specific surface area	350 m ² /g
Carbon load	6.6% C
Coverage of the surface	3.52 µmol/m ²
Efficiency	40,000 N/m; 15,000 N/m
pH range	pH 2-7.5
Shipping eluent	n-Heptane

Ordering information – LiChrospher® 100 CN sorbents

Product	Ordering No.	Particle size	Package	Quantity
LiChrospher® 100 CN	1.19638.0010	5 µm	Glass	10 g
LiChrospher® 100 CN	1.19631.0010	10 µm	Glass	10 g

Ordering information – LiChrospher® 100 CN, stainless steel cartridges LiChroCART®

Product	Ordering No.	Particle size	Dimension length	Dimension i.d.	Contents of one package
LiChrospher® 100 CN	1.50959.0001	5 µm	4 mm	4 mm	10 pieces
LiChrospher® 100 CN	1.50825.0001	5 µm	125 mm	4 mm	1 piece
LiChrospher® 100 CN	1.50892.0001	5 µm	250 mm	4 mm	1 piece
LiChrospher® 100 CN	1.50845.0001	10 µm	250 mm	4 mm	1 piece

The LiChroCART® columns (125, 150 and 250 mm length) in the list above (4 mm i.d.) require part number 1.51486.0001. manu-CART® cartridge column holder, which can be used to hold one cartridge column with or without a 4-4 mm guard column. Additional dimensions available as customized packings see page 292.

► **Superspher®**
Silica carrier for highly efficient separations
page 246

► **LiChrosorb®**
Irregular shaped silica sorbent
page 272

► **Customized packings**
Always the right column
page 292

Accessories for particulate HPLC columns:

► **manu-CART® cartridge holder** for LiChroCART® cartridges
page 296

► **LiChroCART® cartridge**
Different lengths, different internal diameter
page 299

LiChrospher® 100 NH₂

A versatile sorbent for both reversed phase and normal phase chromatography

LiChrospher® 100 NH₂ provides polar and hydrophobic properties and can be used for normal phase chromatography, reversed-phase chromatography and ion exchange chromatography. Typical applications are the separation of carbohydrates (mono-, di- and oligosaccharides) with reversed phase chromatography or the separation of nucleotides with LiChrospher® NH₂ as weak anion exchanger.

Specifications of LiChrospher® 100 NH₂

Sorbent characteristics	Particles of silica with γ-Aminopropyl function
Particle shape	spherical
Particle size	5; 10 μm
Pore size	100 Å (10 nm)
Pore volume	1.25 mL/g
Specific surface area	350 m ² /g
Carbon load	4.6% C
Coverage of the surface	4.1 μmol/m ²
Efficiency	25,000 N/m; 20,000 N/m
pH range	pH 2-7.5
Shipping eluent	n-Heptane

Ordering information – LiChrospher® 100 NH₂ sorbents

Product	Ordering No.	Particle size	Package	Quantity
LiChrospher® 100 NH ₂	1.16178.0010	5 μm	Glass	10 g

Ordering information – LiChrospher® 100 NH₂, stainless steel cartridges LiChroCART®

Product	Ordering No.	Particle size	Dimension length	Dimension i.d.	Contents of one package
LiChrospher® 100 NH ₂	1.50958.0001	5 μm	4 mm	4 mm	10 pieces
LiChrospher® 100 NH ₂	1.50932.0001	5 μm	25 mm	4 mm	3 pieces
LiChrospher® 100 NH ₂	1.50824.0001	5 μm	125 mm	4 mm	1 piece
LiChrospher® 100 NH ₂	1.50834.0001	5 μm	250 mm	4 mm	1 piece
LiChrospher® 100 NH ₂	1.50844.0001	10 μm	250 mm	4 mm	1 piece

The LiChroCART® columns (125, 150 and 250 mm length) in the list above (4 mm i.d.) require part number 1.51486.0001, manu-CART® cartridge column holder, which can be used to hold one cartridge column with or without a 4-4 mm guard column. Additional dimensions available as customized packings see page 292.

► **Purospher® STAR Si (Silica) and NH₂ (Amino-phase)**
page 238

► **Superspher®**
Silica carrier for highly efficient separations
page 246

► **LiChrosorb®**
Irregular shaped silica sorbent
page 272

► **Customized packings**
Always the right column
page 292

Accessories for particulate HPLC columns:

► **manu-CART® cartridge holder for LiChroCART® cartridges**
page 296

► **LiChroCART® cartridge**
Different lengths, different internal diameter
page 299

LiChrospher® 100 DIOL

Excellent for complex samples with polar and hydrophobic characteristics and for exclusion chromatography

LiChrospher® 100 DIOL provides both polar and hydrophobic properties, thus can be used as a less polar alternative to LiChrospher® Si 60 in normal phase applications or as a less hydrophobic alternative with some limitations to LiChrospher® RP-8 in reversed-phase applications. The combination of weak hydrophobic interactions and polar interactions enables successful separations of complex samples. In addition, LiChrospher® DIOL is also suitable for exclusion chromatography.

Specifications of LiChrospher® 100 DIOL

Sorbent characteristics	Particles of silica with Diol function on C-chains
Particle shape	spherical
Particle size	5; 10 µm
Pore size	100 Å (10 nm)
Pore volume	1.25 mL/g
Specific surface area	350 m ² /g
Carbon load	8.0% C
Coverage of the surface	3.87 µmol/m ²
Efficiency	45,000 N/m; 20,000 N/m
pH range	pH 2-7.5
Shipping eluent	n-Heptane

Ordering information – LiChrospher® 100 DIOL sorbents

Product	Ordering No.	Particle size	Package	Quantity
LiChrospher® 100 DIOL	1.16152.0010	5 µm	Glass	10 g

Ordering information – LiChrospher® 100 DIOL, stainless steel cartridges LiChroCART®

Product	Ordering No.	Particle size	Dimension length	Dimension i.d.	Contents of one package
LiChrospher® 100 DIOL	1.50960.0001	5 µm	4 mm	4 mm	10 pieces
LiChrospher® 100 DIOL	1.50826.0001	5 µm	125 mm	4 mm	1 piece
LiChrospher® 100 DIOL	1.50836.0001	5 µm	250 mm	4 mm	1 piece

The LiChroCART® columns (125, 150 and 250 mm length) in the list above (4 mm i.d.) require part number 1.51486.0001. manu-CART® cartridge column holder, which can be used to hold one cartridge column with or without a 4-4 mm guard column. Additional dimensions available as customized packings see page 292.

► **Superspher®**
Silica carrier for highly efficient separations
page 246

► **LiChrosorb®**
Irregular shaped silica sorbent
page 272

► **Customized packings**
Always the right column
page 292

Accessories for particulate HPLC columns:

► **manu-CART® cartridge holder** for LiChroCART® cartridges
page 296

► **LiChroCART® cartridge**
Different lengths, different internal diameter
page 299

LiChrospher® Si 60 and Si 100

LiChrospher® Si 60 and Si 100 are versatile HPLC sorbents based on spherical silica particles providing polar properties and to be used for normal phase chromatography.

Specifications	LiChrospher® Si 60	LiChrospher® Si 100
Sorbent characteristics	Particles of silica	Particles of silica
Particle shape	spherical	spherical
Particle size	5; 10 µm	5; 10 µm
Pore size	60 Å (60 nm)	100 Å (10 nm)
Pore volume	0.85 mL/g	1.25 mL/g
Specific surface area	700 m ² /g	400 m ² /g
Carbon load	12.5% C	13.0% C
Coverage of the surface	4.04 µmol/m ²	4.44 µmol/m ²
Efficiency	55,000 N/m; 20,000 N/m	55,000 N/m; 20,000 N/m
pH range	pH 2-7.5	pH 2-7.5
Shipping eluent	n-Heptane	n-Heptane

Ordering information – LiChrospher® Si, sorbents

Product	Ordering No.	Particle size	Package	Quantity
LiChrospher® Si 60	1.19640.0010	5 µm	Glass	10 g
LiChrospher® Si 60	1.19640.0100	5 µm	Glass	100 g
LiChrospher® Si 60	1.19629.0010	10 µm	Glass	10 g

Ordering information – LiChrospher® Si, stainless steel cartridges LiChroCART®

Product	Ordering No.	Particle size	Dimension length	Dimension i.d.	Contents of one package
LiChrospher® Si 60	1.50955.0001	5 µm	4 mm	4 mm	10 pieces
LiChrospher® Si 60	1.50928.0001	5 µm	25 mm	4 mm	3 pieces
LiChrospher® Si 60	1.50820.0001	5 µm	125 mm	4 mm	1 piece
LiChrospher® Si 60	1.50830.0001	5 µm	250 mm	4 mm	1 piece
LiChrospher® Si 60	1.50840.0001	10 µm	250 mm	4 mm	1 piece
LiChrospher® Si 60	1.50850.0001	10 µm	250 mm	10 mm	1 piece

The LiChroCART® columns (125, 150 and 250 mm length) in the list above (4 mm i.d.) require part number 1.51486.0001 manu-CART® cartridge column holder, which can be used to hold one cartridge column with or without a 4–4 mm guard column. LiChroCART® columns 250–10 mm require part number 1.51419.0001 manu-CART® 10. Additional dimensions available as customized packings see page 292.

Ordering information – LiChrospher® Si, stainless steel columns Hibar® RT

Product	Ordering No.	Particle size	Dimension length	Dimension i.d.	Contents of one package
LiChrospher® Si 100	1.50316.0001	5 µm	250 mm	4 mm	1 piece

The Hibar® columns are complete with endfittings. When using a guard column with a Hibar® column, we recommend part number 1.51487.0001 guard column cartridge holder for 4–4 mm guard column cartridges LiChroCART®. Additional dimensions available as customized packings see page 292.

► Purospher® STAR Si (Silica) and NH₂ (Amino-phase) [page 238](#)

► Superspher® Silica carrier for highly efficient separations [page 246](#)

► LiChrospher® Silica carrier for constant top-rate results [page 250](#)

► LiChrosorb® Irregular shaped silica sorbent [page 272](#)

► Customized packings Always the right column [page 292](#)

Accessories for particulate HPLC columns:

► manu-CART® cartridge holder for LiChroCART® cartridges [page 296](#)

► LiChroCART® cartridge Different lengths, different internal diameter [page 299](#)

► Standardized silica gels [page 336](#)

LiChrosorb®

Irregular shaped silica sorbent

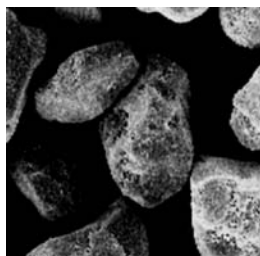

LiChrosorb® is one of the most successful and reliable packing materials, used in HPLC for more than 25 years and documented in the literature in the form of several thousand applications. **The totally porous irregular particles are finely graded in the 5, 7 and 10 µm range.**

LiChrosorb® packing materials offer the complete program of non-polar derivatives (RP-8, RP-18, RP-select B) polar derivatives (Si 60 and Si 100). In addition to the analytical cartridges and columns, such as LiChroCART® 250-4 or Hibar® RT 250-4, Merck Millipore offers semi-preparative cartridges LiChroCART® 250-10 as well as Hibar® RT columns 250-10, packed on request with various LiChrosorb® packing materials.

Specifications of LiChrosorb® packing materials

Packing material	Characteristics	Spec. surface area S_{BET} [m ² /g]	Pore volume V_p [mL/g]	Particle size d_p [µm]	% C	Surface coverage [µmol/m ²]
LiChrosorb® Si 60	irregular particles of silica medium pore size: 6 nm (60Å)	500	0.75	5, 7, 10	–	–
LiChrosorb® Si 100	irregular particles of silica medium pore size: 10 nm (100Å)	300	1.0	10	–	–
LiChrosorb® RP-8	irregular particles of silica with octyl derivative	300	1.0	5, 7, 10	9.5	3.4
LiChrosorb® RP-18	irregular particles of silica with octadecyl derivative	300	1.0	5, 10	16.2	3.0

Fraction range of LiChrosorb® packing materials

Product	Spec. pore volume [mL/g]	Spec. surface area [m ² /g]	Fractionation range (Polystyrene/THF) [g/mol]
LiChrosorb® Si 40	50 - 4 · 10 ³	0.6	800
LiChrosorb® Si 60	80 - 2 · 10 ⁴	0.7	500
LiChrosorb® Si 100	200 - 4 · 10 ⁴	1.0	300
LiChrosorb® RP-8	100 - 4 · 10 ⁴	1.0	300
LiChrosorb® RP-18	100 - 4 · 10 ⁴	1.0	300

- ▶ Customized packings
Always the right column
page 292

Accessories for particulate HPLC columns:

- ▶ manu-CART® cartridge holder for LiChroCART® cartridges
page 296

- ▶ LiChroCART® cartridge
Different lengths, different internal diameter
page 299

- ▶ Hibar® column
page 301

- ▶ LiChroprep®
page 338

LiChrosorb®

A successful packing material from the start

Ordering information – LiChrosorb® sorbents

Product	Ordering No.	Particle size	Package	Quantity
LiChrosorb® Si 60	1.09335.0010	7 µm	Glass	10 g
LiChrosorb® Si 60	1.09335.0100	7 µm	Glass	100 g
LiChrosorb® Si 60	1.09387.0100	10 µm	Glass	100 g
LiChrosorb® Si 100	1.09309.0010	10 µm	Glass	10 g
LiChrosorb® Si 100	1.09309.0100	10 µm	Glass	100 g
LiChrosorb® RP-8	1.09332.0010	5 µm	Glass	10 g
LiChrosorb® RP-8	1.09341.0010	7 µm	Glass	10 g
LiChrosorb® RP-8	1.09318.0010	10 µm	Glass	10 g
LiChrosorb® RP-8	1.09318.0100	10 µm	Glass	100 g
LiChrosorb® RP-18	1.09333.0010	5 µm	Glass	10 g
LiChrosorb® RP-18	1.09334.0010	10 µm	Glass	10 g



Ordering information – LiChrosorb®, stainless steel cartridges LiChroCART®

Product	Ordering No.	Particle size	Dimension length	Dimension i.d.	Contents of one package
LiChrosorb® Si 60	1.51343.0001	5 µm	125 mm	4 mm	1 piece
LiChrosorb® Si 60	1.51351.0001	5 µm	250 mm	4 mm	1 piece
LiChrosorb® RP-8	1.51345.0001	5 µm	125 mm	4 mm	1 piece
LiChrosorb® RP-8	1.51353.0001	5 µm	250 mm	4 mm	1 piece
LiChrosorb® RP-8	1.51354.0001	10 µm	250 mm	4 mm	1 piece
LiChrosorb® RP-18	1.51349.0001	5 µm	125 mm	4 mm	1 piece
LiChrosorb® RP-18	1.51355.0001	5 µm	250 mm	4 mm	1 piece
LiChrosorb® RP-18	1.51356.0001	10 µm	250 mm	4 mm	1 piece

The LiChroCART® columns (125, 150 and 250 mm length) in the list above (4 mm i.d.) require part number 1.51486.0001 manu-CART® cartridge column holder, which can be used to hold one cartridge column with or without a 4–4 mm guard column. LiChroCART® columns 250–10 mm require part number 1.51419.0001 manu-CART® 10. Additional dimensions available as customized packings see page 292.

Ordering information – LiChrosorb®, stainless steel columns Hibar® RT

Product	Ordering No.	Particle size	Dimension length	Dimension i.d.	Contents of one package
LiChrosorb® Si 60	1.50388.0001	5 µm	250 mm	4 mm	1 piece
LiChrosorb® RP-8	1.50432.0001	5 µm	125 mm	4 mm	1 piece
LiChrosorb® RP-8	1.50332.0001	5 µm	250 mm	4 mm	1 piece
LiChrosorb® RP-8	1.50318.0001	10 µm	250 mm	4 mm	1 piece
LiChrosorb® RP-18	1.50433.0001	5 µm	125 mm	4 mm	1 piece
LiChrosorb® RP-18	1.50333.0001	5 µm	250 mm	4 mm	1 piece
LiChrosorb® RP-18	1.50334.0001	10 µm	250 mm	4 mm	1 piece

The Hibar® columns are complete with endfittings. When using a guard column with a Hibar® column, we recommend part number 1.51487.0001 guard column cartridge holder for 4–4 mm guard column cartridges LiChroCART®. Additional dimensions available as customized packings see page 292.

Aluspher®

Alkaline stable HPLC separations

Due to its stability, alumina, together with alkaline eluents, has enabled new applications to be found for HPLC. Advanced formulation techniques permit the production of spherical alumina particles as a base for Aluspher® 100 RP-select B.

Aluspher® 100 RP-select B is ideal for use with basic eluents, as ionization of basic compounds is suppressed and peak-tailing is avoided. Due to its stability in the range of pH 2-12, Aluspher® 100 RP-select B permits the use of basic eluents such as NaOH for the separation of neutral, basic and acidic compounds.



Specifications of Aluspher® 100 RP-select B

Sorbent characteristics	Alumina particles, coated with polybutadiene (PBD)
Particle shape	spherical
Particle size	5 µm
Pore size	100 Å (10 nm)
Specific surface area	170 m ² /g
Efficiency	55,000 N/m
pH range	pH 2-12
Shipping eluent	Acetonitrile/Water



▶ **LiChrospher® 60 RP-select B** Excellent separations even with basic compounds
page 264

▶ **Customized packings** Always the right column
page 292

Accessories for particulate HPLC columns:

▶ **manu-CART® cartridge holder** for LiChroCART® cartridges
page 296

▶ **LiChroCART® cartridge** Different lengths, different internal diameter
page 299

▶ **Aluminium oxide** for preparative chromatography
page 334

Aluspher® RP-select B

A stable reversed phase stationary phase optimized for applications up to pH 12

Ordering information – Aluspher® 100 RP-select B, stainless steel cartridges LiChroCART®

Product	Ordering No.	Particle size	Dimension length	Dimension i.d.	Contents of one package
Aluspher® 100 RP-select B	1.51311.0001	5 µm	4 mm	4 mm	10 pieces
Aluspher® 100 RP-select B	1.51315.0001	5 µm	125 mm	4 mm	1 piece
Aluspher® 100 RP-select B	1.51318.0001	5 µm	250 mm	4 mm	1 piece

The LiChroCART® columns (125, 150 and 250 mm length) in the list above (4.6 mm i.d.) require part number 1.51486.0001 manu-CART® cartridge column holder, which can be used to hold one cartridge column with or without a 4–4 mm guard column. Additional dimensions available as customized packings see page 292.

Separation examples on Aluspher® 100 RP-select B

Amphetamine compounds

Column	LiChroCART® 250-4 Aluspher® 100 RP-select B, 5 µm
Mobile phase	Methanol/0.025 M NaOH 25/75 (v/v)
Flow rate	1.0 mL/min
Detection	UV 215 nm
Temperature	Room temperature
Sample	1. Amphetamine 2. p-Methoxyamphetamine (PMA) 3. Methylenedioxyamphetamine (MDA) 4. Methamphetamine 5. Methylenedioxymethamphetamine (MDMA) 6. Ethylamphetamine 7. Methylenedioxyethylamphetamine (MDEA)

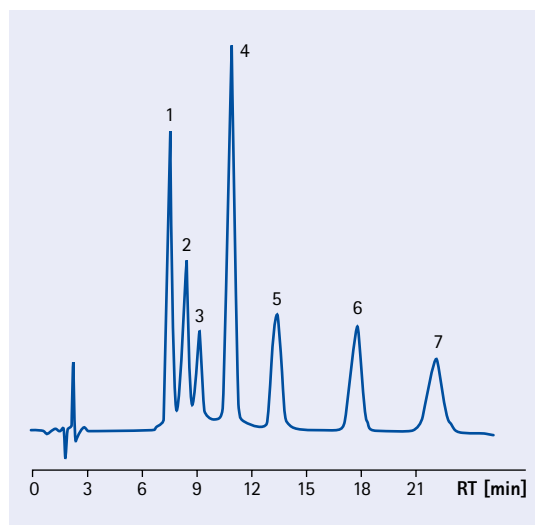

Pharmaceuticals with non-buffered eluent

Column	LiChroCART® 250-4 Aluspher® 100 RP-select B, 5 µm
Mobile phase	Acetonitrile/Water 35/65 (v/v)
Flow rate	1.0 mL/min
Detection	UV 220 nm
Temperature	Room temperature
Sample	1. Levamisole 2. 5-Methyl-5-phenyldantoin (MPH) 3. 5-Phenyl-5-(2-pyridyl)-hydantoin (PPH) 4. 5-(p-Methylphenyl)-5-phenylhydantoin (MPH) 5. Diazepam

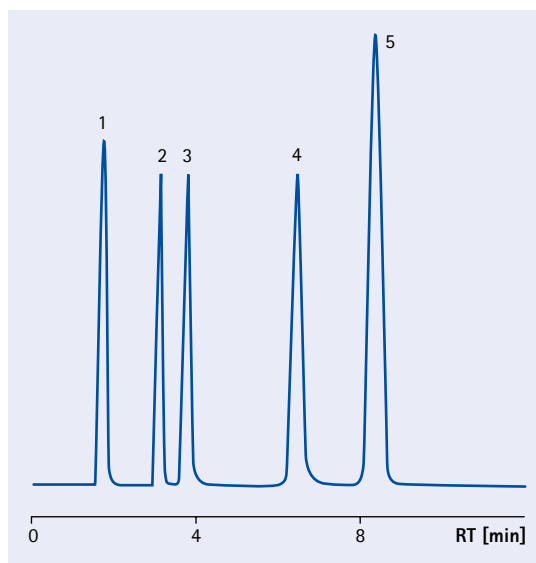

Beta-Blockers with alkaline eluents

Column	LiChroCART® 250-4 Aluspher® 100 RP-select B, 5 µm
Mobile phase	Methanol/0.025 M NaOH 50/50 (v/v)
Flow rate	1.0 mL/min
Detection	UV 220 nm
Temperature	Room temperature
Sample	1. Sotalol 2. Atenolol 3. Metoprolol

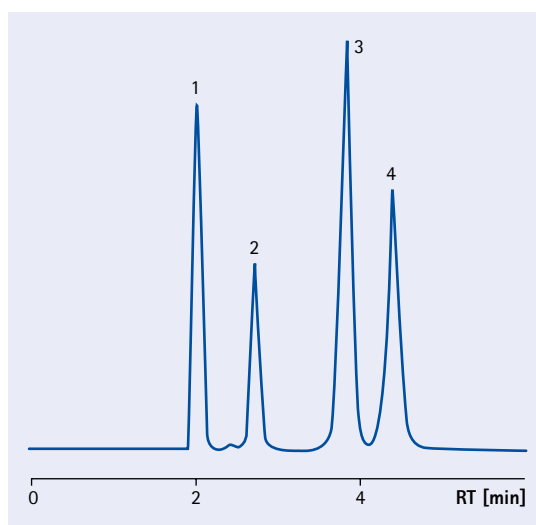

SeQuant® ZIC®-HILIC and ZIC®-pHILIC

The ideal columns for all classes of polar and hydrophilic compounds

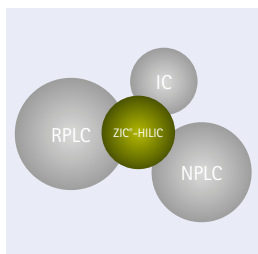

Your ideal choice for separation of all types of polar and hydrophilic compounds is SeQuant® ZIC®-HILIC and ZIC®-pHILIC HPLC columns. Reproducible retention for compounds that have proved difficult to separate on reversed-phase HPLC columns, is ensured by the high-performance, zwitterionic stationary phase in these columns. Straightforward separation of compounds such as acids and bases, anions and cations, carbohydrates, metabolites, metal complexes, amino acids, peptides, protein digests and oligonucleotides can therefore be achieved with a selectivity complementary to reversed-phase columns. Enhanced LC/MS sensitivity is an additional benefit of using these columns.

SeQuant® ZIC®-HILIC and ZIC®-pHILIC HPLC columns are operated in HILIC (Hydrophilic Interaction Liquid Chromatography) mode, which means with buffered aqueous eluents containing high content (> 50%) of organic solvents such as acetonitrile.

ZIC®-HILIC is silica-based, has highest separation efficiency, and is suitable for most HILIC applications. Columns are available in a wide range of formats from capillary to semi-preparative dimensions, and with several different particle sizes and pore sizes. ZIC®-pHILIC is polymer-based, has a wider pH stability range (pH 2-12), making it the choice for extra difficult separations demanding more extreme eluent conditions.

SeQuant® ZIC®-HILIC benefits

- Improved separation of hydrophilic and polar compounds
- Orthogonal selectivity to Reversed Phase
- Optimal combination with LC/MS
- Excellent stability



Specification of SeQuant® ZIC®-HILIC and ZIC®-pHILIC

	Characteristics	Particle size [µm]	Surface area [m²/g]	pH stability	Max temp [°C]
ZIC®-HILIC 100 Å	Bonded zwitterionic sulfobetaine on high-purity spherical silica particles	3.5	180	2-8	70
ZIC®-HILIC 200 Å	Bonded zwitterionic sulfobetaine on high-purity spherical silica particles	3.5, 5	130	2-8	70
ZIC®-pHILIC	Bonded zwitterionic sulfobetaine on polymeric particles	5	-	2-12	50

► **SeQuant® ZIC®-HILIC**
High-performance columns for hydrophilic compounds
page 272

► **SeQuant® ZIC®-pHILIC**
Polymeric columns with extended pH stability for demanding separations of hydrophilic compounds
page 287

What is HILIC?

HILIC or Hydrophilic Interaction Liquid Chromatography is a straightforward chromatographic technique for separation of many types of polar and hydrophilic compounds. To put it simple one can say that HILIC is a normal-phase (NPLC) type of separation but uses reversed-phase (RPLC) type eluents.

Thus, in HILIC one has:

- A column with a hydrophilic stationary phase
- An eluent with water, buffer and a high concentration of water-miscible organic solvent.

A typical HILIC application uses an eluent with 50 - 95% organic solvent in an aqueous buffer that has a high solubility in the solvent, for example acetonitrile in ammonium acetate. The elution order in HILIC is roughly the opposite of that in RPLC and retention increases with hydrophilicity and charge of the analyte. This enables straightforward separation of compounds that would otherwise elute in the void volume on RPLC columns.

Schematic illustration of the processes causing retention on the ZIC®-HILIC stationary phase

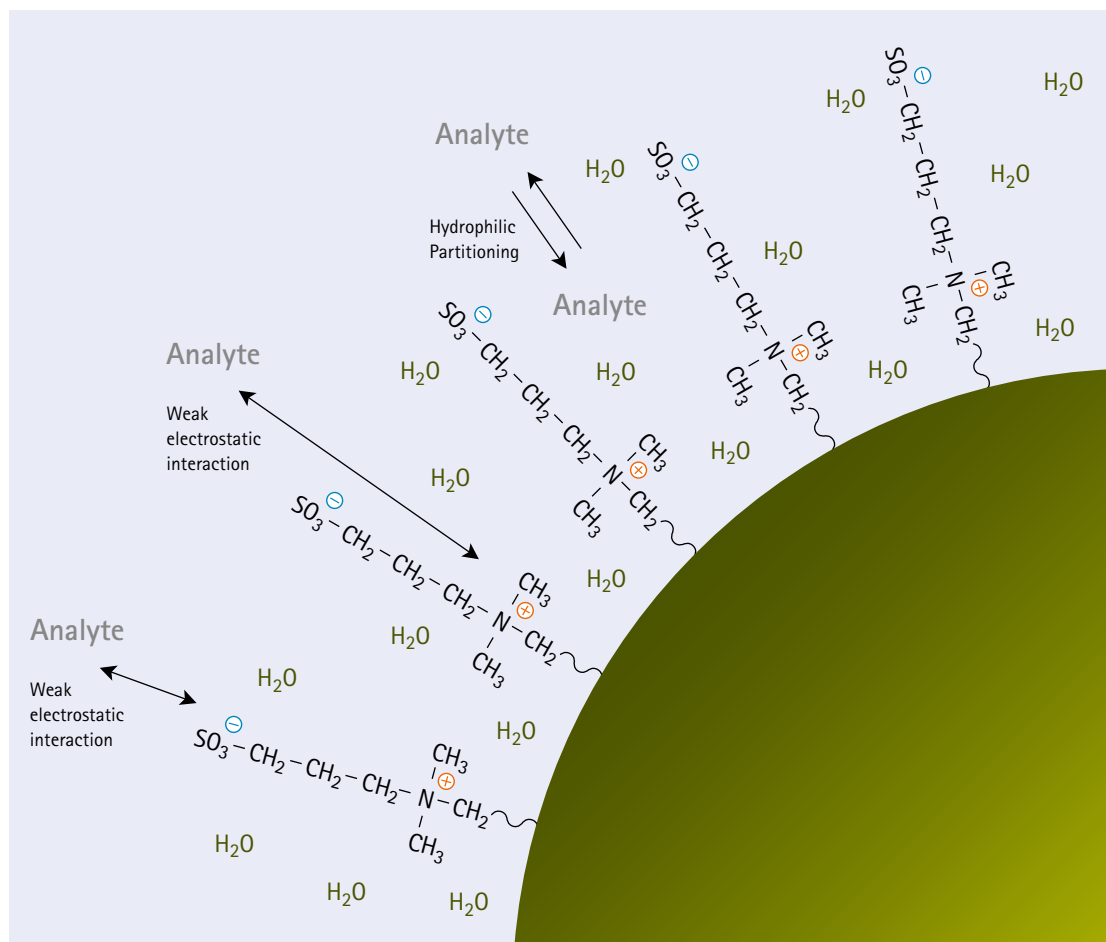

Characteristics

ZIC®-HILIC and ZIC®-pHILIC sorbents have a bonded stationary phase consisting of a highly polar, permanent zwitterionic sulfobetaine structure. Separation selectivity is favored by the 1:1 zwitterion charge balance, which makes the column overall neutral, with weak, but important, ionic interactions.

The highly hydrophilic sulfobetaine structure is very good at establishing an immobilized water-rich layer within the stationary phase – a feature that is fundamentally important for all HILIC separations. Tuning of the selectivity on the ZIC®-HILIC and ZIC®-pHILIC column during method development is facilitated by the pH-independent permanent zwitterion, ensuring that only the analytes (and not the column) is affected during eluent optimization.



Additional information

For the most up to date information on products and applications please visit www.sequant.com and ask for your free copy of the booklet **A Practical Guide to HILIC**

ZIC®-HILIC is for all classes of polar and hydrophilic compounds

With the ZIC®-HILIC column separation of polar and hydrophilic compounds is straightforward. The selectivity offered by ZIC®-HILIC is suitable for a wide variety of molecules containing hydrophilic or ionizable functional groups. This includes compounds such as carbohydrates, metabolites, acids and bases, organic and inorganic ions, metal complexes, amino acids, peptides, protein digests, plant and cell extracts, plus much more.

These compounds are normally characterized by a small or negative log *P* value * and have poor retention on reversed-phase columns. The ZIC®-HILIC column is designed to retain and separate these types of polar and hydrophilic molecules with a selectivity that is orthogonal to reversed-phase.

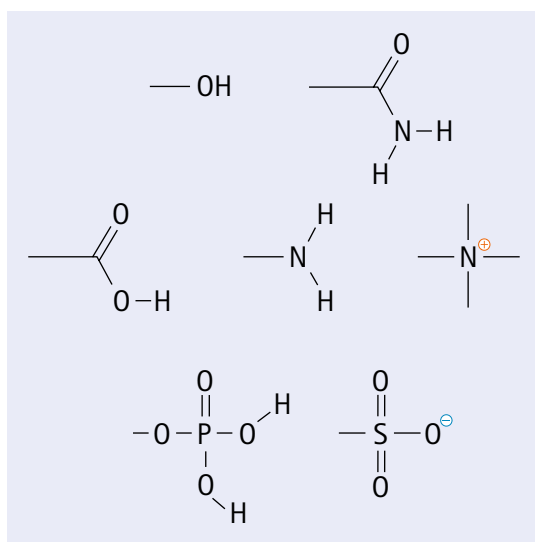

Examples of hydrophilic functional groups

ZIC®-HILIC range

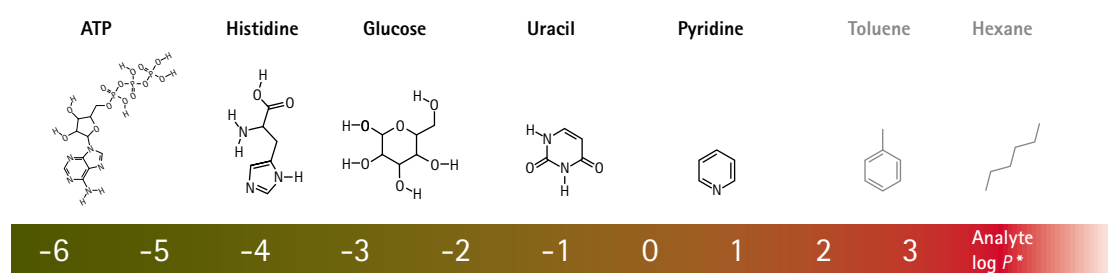

Examples of polar and hydrophilic compounds with different log *P* values* that can be separated with ZIC®-HILIC. In contrast, two compounds that are too hydrophobic to be retained (toluene and hexane) are also displayed. (* octanol-water partition coefficient)

SeQuant® ZIC®-HILIC

High-performance columns for hydrophilic compounds

Ordering information – SeQuant® ZIC®-HILIC analytical PEEK columns

Product	Ordering No.	Particle size	Porosity	Dimension length	Dimension i.d.	Contents of one package
ZIC®-HILIC PEEK HPLC column	1.50439.0001	3.5 µm	100 Å	20 mm	2.1 mm	1 piece
ZIC®-HILIC PEEK HPLC column	1.50440.0001	3.5 µm	100 Å	50 mm	2.1 mm	1 piece
ZIC®-HILIC PEEK HPLC column	1.50441.0001	3.5 µm	100 Å	100 mm	2.1 mm	1 piece
ZIC®-HILIC PEEK HPLC column	1.50442.0001	3.5 µm	100 Å	150 mm	2.1 mm	1 piece
ZIC®-HILIC PEEK HPLC column	1.50443.0001	3.5 µm	100 Å	250 mm	2.1 mm	1 piece
ZIC®-HILIC PEEK HPLC column	1.50444.0001	3.5 µm	100 Å	150 mm	4.6 mm	1 piece
ZIC®-HILIC PEEK HPLC column	1.50445.0001	3.5 µm	200 Å	50 mm	2.1 mm	1 piece
ZIC®-HILIC PEEK HPLC column	1.50447.0001	3.5 µm	200 Å	100 mm	2.1 mm	1 piece
ZIC®-HILIC PEEK HPLC column	1.50448.0001	3.5 µm	200 Å	150 mm	2.1 mm	1 piece
ZIC®-HILIC PEEK HPLC column	1.50446.0001	3.5 µm	200 Å	50 mm	4.6 mm	1 piece
ZIC®-HILIC PEEK HPLC column	1.50449.0001	3.5 µm	200 Å	150 mm	4.6 mm	1 piece
ZIC®-HILIC PEEK HPLC column	1.50450.0001	5 µm	200 Å	50 mm	2.1 mm	1 piece
ZIC®-HILIC PEEK HPLC column	1.50452.0001	5 µm	200 Å	100 mm	2.1 mm	1 piece
ZIC®-HILIC PEEK HPLC column	1.50454.0001	5 µm	200 Å	150 mm	2.1 mm	1 piece
ZIC®-HILIC PEEK HPLC column	1.50457.0001	5 µm	200 Å	250 mm	2.1 mm	1 piece
ZIC®-HILIC PEEK HPLC column	1.50451.0001	5 µm	200 Å	50 mm	4.6 mm	1 piece
ZIC®-HILIC PEEK HPLC column	1.50453.0001	5 µm	200 Å	100 mm	4.6 mm	1 piece
ZIC®-HILIC PEEK HPLC column	1.50455.0001	5 µm	200 Å	150 mm	4.6 mm	1 piece
ZIC®-HILIC PEEK HPLC column	1.50458.0001	5 µm	200 Å	250 mm	4.6 mm	1 piece
ZIC®-HILIC PEEK fitting guard column (5-pak)	1.50434.0001	5 µm	200 Å	14 mm	1 mm	5 pieces
ZIC®-HILIC guard column (1-pak)	1.50435.0001	5 µm	200 Å	20 mm	2.1 mm	1 piece
ZIC®-HILIC guard column incl. column coupler	1.50436.0001	5 µm	200 Å	20 mm	2.1 mm	3 pieces



Ordering information – SeQuant® ZIC®-HILIC Nano, Capillary and Microbore columns

Product	Ordering No.	Particle size	Porosity	Dimension length	Dimension i.d.	Contents of one package
ZIC®-HILIC Microbore column	1.50487.0001	3.5 µm	100 Å	150 mm	1 mm	1 piece
ZIC®-HILIC Microbore column	1.50478.0001	3.5 µm	200 Å	30 mm	1 mm	1 piece
ZIC®-HILIC Microbore column	1.50480.0001	3.5 µm	200 Å	150 mm	1 mm	1 piece
ZIC®-HILIC Nano column	1.50466.0001	3.5 µm	200 Å	100 mm	100 µm	1 piece
ZIC®-HILIC Capillary column	1.50489.0001	3.5 µm	200 Å	30 mm	300 µm	1 piece
ZIC®-HILIC Capillary column	1.50479.0001	3.5 µm	200 Å	150 mm	300 µm	1 piece
ZIC®-HILIC Microbore column	1.50482.0001	5 µm	200 Å	150 mm	1 mm	1 piece
ZIC®-HILIC Nano column	1.50465.0001	5 µm	200 Å	150 mm	75 µm	1 piece
ZIC®-HILIC Capillary column	1.50491.0001	5 µm	200 Å	30 mm	300 µm	1 piece
ZIC®-HILIC Capillary column	1.50481.0001	5 µm	200 Å	150 mm	300 µm	1 piece
ZIC®-HILIC guard column (1-pak)	1.50484.0001	5 µm	200 Å	5 mm	300 µm	1 piece
ZIC®-HILIC guard column (5-pak)	1.50492.0001	5 µm	200 Å	5 mm	300 µm	5 pieces
ZIC®-HILIC guard column (1-pak)	1.50483.0001	5 µm	200 Å	5 mm	1 mm	1 piece
ZIC®-HILIC guard column (5-pak)	1.50490.0001	5 µm	200 Å	5 mm	1 mm	5 pieces

Ordering information – SeQuant® ZIC®-HILIC semi-preparative columns

Product	Ordering No.	Particle size	Porosity	Dimension length	Dimension i.d.	Contents of one package
ZIC®-HILIC PEEK HPLC column	1.50456.0001	5 µm	200 Å	150 mm	7.5 mm	1 piece
ZIC®-HILIC Stainless Steel column	1.50495.0001	5 µm	200 Å	50 mm	10 mm	1 piece
ZIC®-HILIC Stainless Steel column	1.50493.0001	5 µm	200 Å	150 mm	10 mm	1 piece
ZIC®-HILIC Stainless Steel column	1.50494.0001	5 µm	200 Å	250 mm	10 mm	1 piece
ZIC®-HILIC Stainless Steel column	1.50496.0001	5 µm	200 Å	50 mm	20 mm	1 piece
ZIC®-HILIC Stainless Steel column	1.50497.0001	5 µm	200 Å	150 mm	20 mm	1 piece

For more information please visit www.merck-chemicals.com/zichilic or www.sequant.com/zichilic



Separation examples on ZIC®-HILIC

Separation of cyanuric acid and melamine food contaminants

Column	ZIC®-HILIC 150 x 2.1 mm, 5 µm, 200 Å [Ord. No. 1.50454.0001]			
Mobile phase	A: 95% acetonitrile in 0.1% aqueous formic acid B: 50% acetonitrile in 20 mM aqueous ammonium formate			
Gradient	Time	% A	% B	Flow rate [mL/min]
	0	100	0	0.4
	4.2	100	0	0.4
	8.0	65	35	0.4
	8.5	65	35	0.4
	9.0	25	75	0.4
	11.0	25	75	0.4
	11.2	100	0	0.6
	13.0	100	0	0.6
	14.0	100	0	0.4
Detection	MS/MS, -ESI and +ESI			
Temperature	30°C			
Injection volume	5 µL			
Sample	Standard in mobile phase (7 ng/mL) equivalent to 1 µg/g			
<i>Courtesy of</i>	<i>David N. Heller, FDA Center for Veterinary Medicine, Laurel, MD 20708 USA</i>			

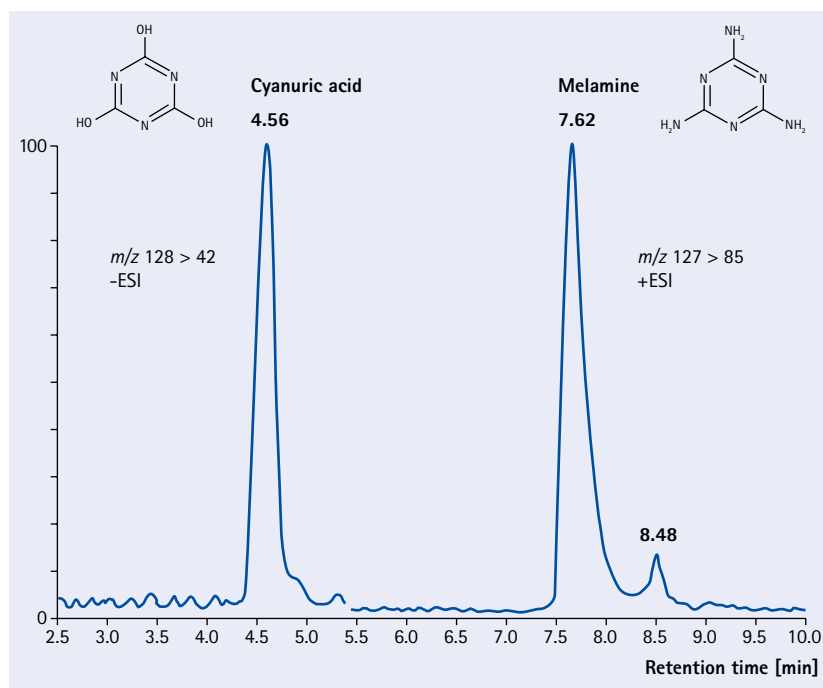

Reference *David N. Heller and Cristina B. Nochetto, Rapid Commun. Mass Spectrom., 22 (2008) 3624–3632. DOI: 10.1002/rcm.3779*

Separation of chlormequat and mepiquat pesticides

Column	ZIC®-HILIC 100 x 2.1 mm, 3.5 µm, 200 Å [Ord. No. 1.50447.0001]			
Mobile phase	80% Acetonitrile and 20% Ammonium Acetate 25 mM (v/v)			
Flow rate	0.2 mL/min			
Detection	Electrospray-MS in positive mode (ESI+), Single ion monitoring (SIM) at m/z 114 and 122			
Injection volume	20 µL			
Sample	Chlormequat and Mepiquat standard in mobile phase			
<i>Courtesy of</i>	<i>Dr.-Ing. Ludmila Havlik, Chemisches Labor Dr. Wirts + Partner, Hannover, Germany, www.wirts.de</i>			

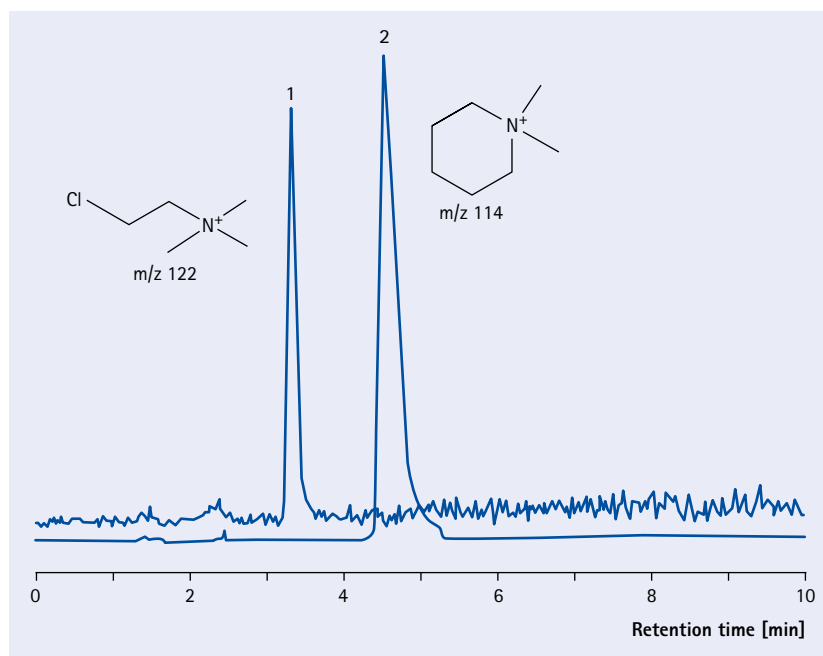

Separation of inorganic anions and cations

Column	ZIC®-HILIC 150 x 2.1 mm, 3.5 µm, 100 Å [Ord. No. 1.50442.0001]		
Mobile phase	A: Acetonitrile B: 20mM Ammonium Formate, pH 3		
Gradient	Time	% A	% B
	0.0	80	20
	3.0	80	20
	10.0	20	80
	13.0	20	80
	13.1	80	20
	23.0	80	20
Flow rate	0.3 mL/min		
Detection	ELSD, SEDEX 85LT, 40°C, 3.5 bar		
Temperature	40°C		
Injection volume	2 µL		
Sample	1.-8.	LOD [based on S/N=3]	
	1. NO ₃	2.6 mg/L	
	2. Cl	2.3 mg/L	
	3. K	5.1 mg/L	
	4. Na	0.9 mg/L	
	5. PO ₄	15.8 mg/L	
	6. SO ₄	2.4 mg/L	
	7. Mg	0.3 mg/L	
	8. Ca	0.7 mg/L	

Courtesy of *Eric Verette, SEDERE S.A.S, France*

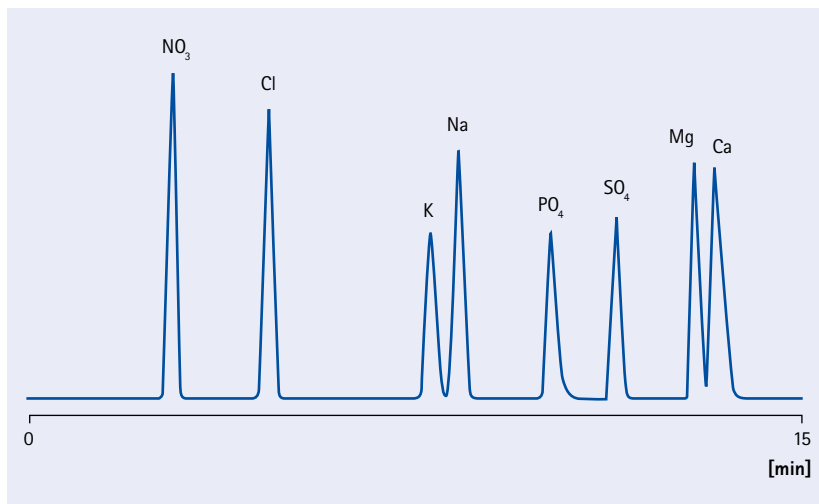

Separation of amino acids

Column	ZIC®-HILIC 150 x 4.6 mm, 3.5 µm, 100 Å [Ord. No. 1.50444.0001]	
Mobile phase	80% Acetonitrile 20% Ammonium acetate in water, 50 mM pH adjusted to 4.5 with formic acid	
Flow rate	0.75 mL/min	
Detection	Refractive Index, cell 9 µL, 40°C	
Temperature	40°C	
Injection volume	50 µL	
Sample	1. 2-Amino-5-Hydroxy benzoic acid	100 ppm
	2. Tryptophan	100 ppm
	3. Isoleucine	100 ppm
	4. Methionine	100 ppm
	5. Lysine	100 ppm
	6. Threonine	100 ppm

Courtesy of *Gora Sharangi, Merck India Application Lab*

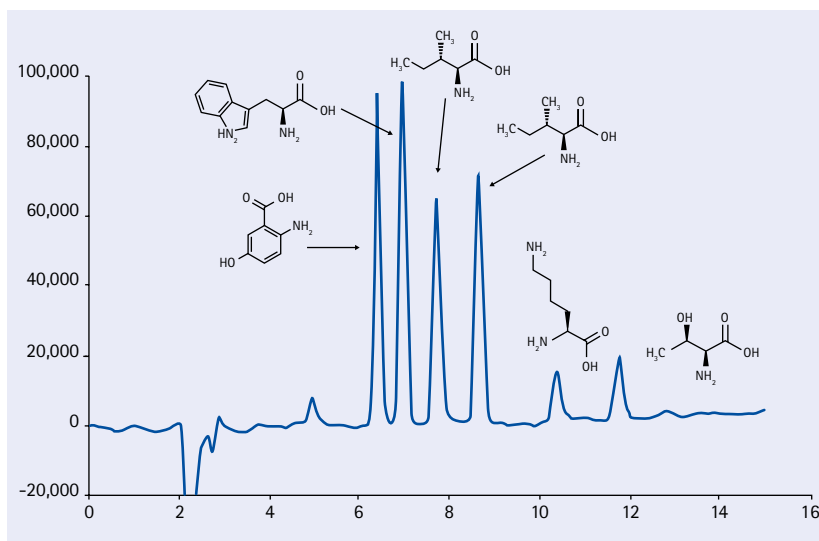

Separation examples on ZIC®-HILIC

Bioanalysis of methyl malonic acid

Column	ZIC®-HILIC 100 x 2.1 mm, 3.5 µm, 100 Å [Ord. No. 1.50441.0001]
Mobile phase	A: 80% (v/v) acetonitrile B: 20% (v/v) 100 mM NH ₄ Ac buffer pH 4.5
Flow rate	0.4 mL/min
Detection	MS-ESI- with SIM at 117.2 m/z Drying-gas flow rate 10 L/min Drying-gas temperature 300°C Capillary voltage 3.0 kV
Injection volume	4 µL
Sample	Precipitated-treated plasma sample containing 0.137 mol/L MMA
Reference	H-A Lakso, P. Appelblad, J. Schneede <i>Clin. Chem.</i> , 54 (2008) 2028 DOI: 10.1373/clinchem.2007.101253

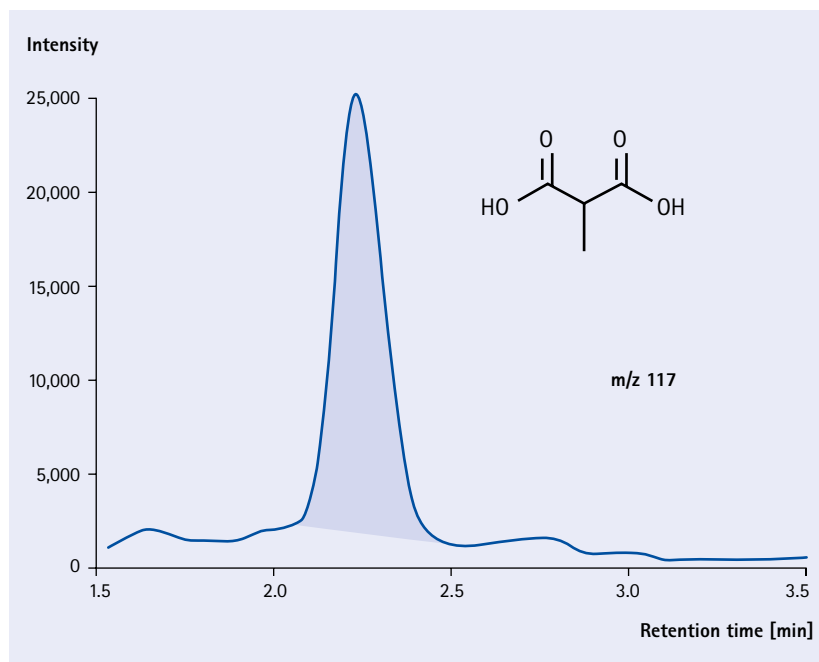

Separation of bovine serum albumin tryptic digest

Column	ZIC®-HILIC 150 x 0.3 mm, 5 µm, 200 Å [Ord. No. 1.50481.0001]
Mobile phase	A: 100% Acetonitrile with 0.25% formic acid B: 100% Milli-Q water with a 0.25% formic acid
Gradient	Time % A % B 0 90 10 40 10 0
Flow rate	5 µL/min
Detection	MicroMass Ultima-QTOF Needle voltage 3.1 kV Cone voltage 45 V Collision energy 10 V Scan range 400-1800 m/z Cycle time 1.5 s
Injection volume	1 µL
Sample	10 pmole digested sample injected in mobile phase

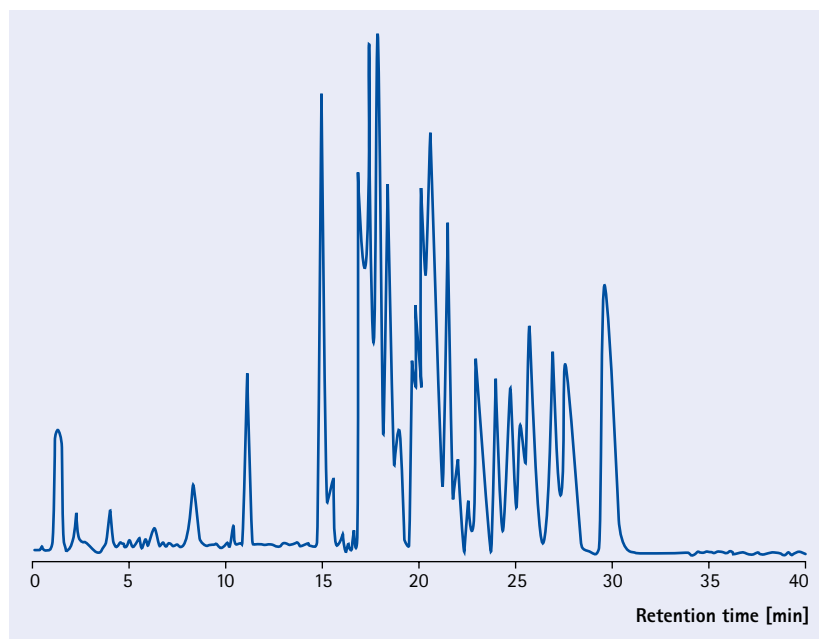

SeQuant® ZIC®-pHILIC

Polymeric columns with extended pH stability for demanding separations of hydrophilic compounds

Ordering information – SeQuant® ZIC®-pHILIC analytical PEEK columns

Product	Ordering No.	Particle size	Beads	Dimension length	Dimension i.d.	Contents of one package
ZIC®-pHILIC PEEK HPLC column	1.50459.0001	5 µm	polymeric	50 mm	2.1 mm	1 piece
ZIC®-pHILIC PEEK HPLC column	1.50462.0001	5 µm	polymeric	100 mm	2.1 mm	1 piece
ZIC®-pHILIC PEEK HPLC column	1.50460.0001	5 µm	polymeric	150 mm	2.1 mm	1 piece
ZIC®-pHILIC PEEK HPLC column	1.50463.0001	5 µm	polymeric	50 mm	4.6 mm	1 piece
ZIC®-pHILIC PEEK HPLC column	1.50464.0001	5 µm	polymeric	100 mm	4.6 mm	1 piece
ZIC®-pHILIC PEEK HPLC column	1.50461.0001	5 µm	polymeric	150 mm	4.6 mm	1 piece
ZIC®-pHILIC Guard column (1-pak)	1.50437.0001	5 µm	polymeric	20 mm	2.1 mm	1 piece
ZIC®-pHILIC Guard column incl. column coupler (3-pak)	1.50438.0001	5 µm	polymeric	20 mm	2.1 mm	3 pieces

For more information please visit www.merck-chemicals.com/zicphilic or www.sequant.com/zicphilic

Example of enhanced selectivity at high pH

The application example below illustrates how the selectivity of the ZIC®-pHILIC material can be enhanced by performing the separation at elevated pH.

The chromatograms show isocratic separations of gentisic acid, protocatechuic acid and isophthalic acid on a ZIC®-pHILIC column. The pH-increase also results in higher retention and improved peak shape for these analytes.

Separation of gentisic acid, protocatechuic acid, and isophthalic acid on a ZIC®-pHILIC column

Column	ZIC®-pHILIC column	
Mobile phase	75:25 Acetonitrile / aqueous buffer pumped at 0.5 mL/min	
Buffer salt	Ammonium acetate	17 mM, pH 6.8
	or	
	Ammonium carbonate	17 mM, pH 9.6

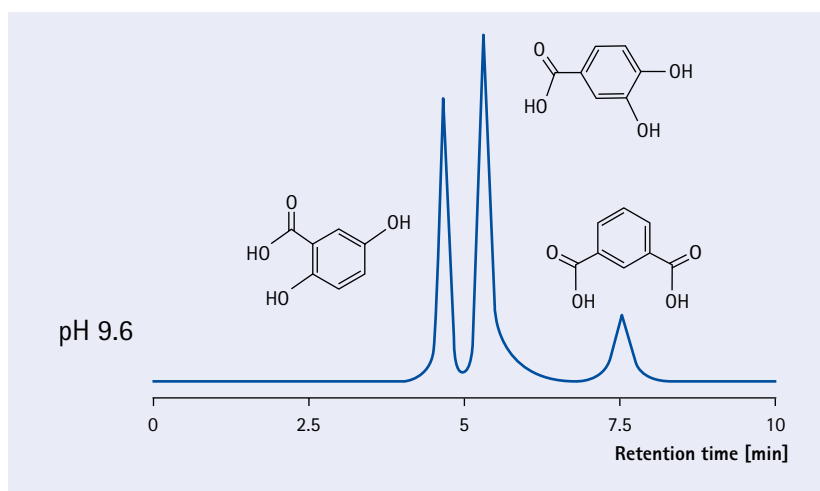
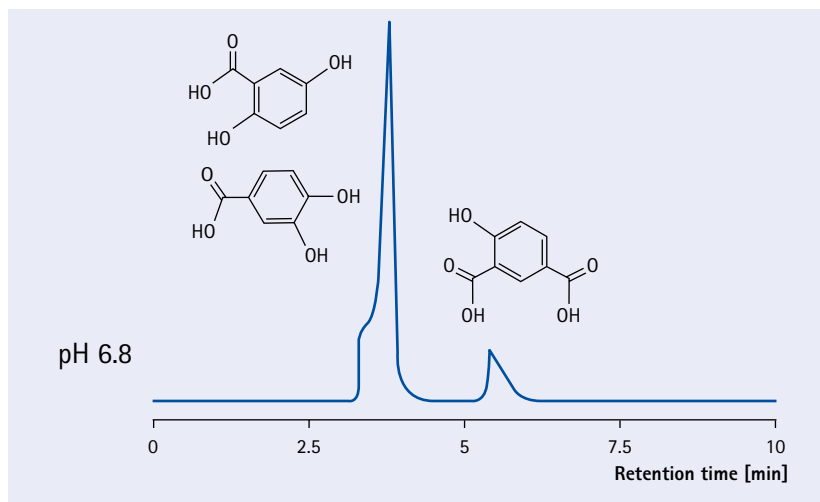

Chiral stationary phases

Always the proper column for enantiomer analysis

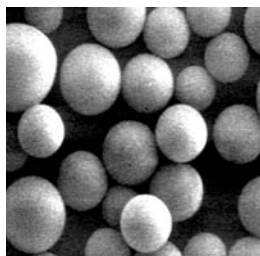

Chiral stationary phases

Chirality has become vitally important in the pharmaceutical, chemical, and agricultural industries. The differences which make compounds chiral can produce critically different pharmacological effects in biological systems. As a result, demand for stereoselective separation techniques and analytical assays to evaluate the enantiomeric purity of chiral compounds has increased. Chiral chromatography has become a necessary tool – not only for the analytical determination of enantiomeric purity, but also for the isolation of pure enantiomers.

The chromatographic enantiomer separation by chiral stationary phase is an efficient and rapid method in the control of chiral pharmaceuticals or flavour ingredients.

ChiraDex® for the chiral separation of hydrocarbons, steroids, phenol esters and derivatives, aromatic amines, heterocycles with 5-membered ring to 7-membered ring.

Specifications of ChiraDex®

Sorbent characteristics	Spherical silica particles with covalently bonded beta-cyclodextrin particles
Particle shape	spherical
Particle size	5 µm
Pore size	10 nm (100 Å)
Specific surface area	300 - 360 m ² /g
Chiral selector	Beta-cyclodextrin

▶ **Column selection guide**
page 152

▶ **ChiraDex®**
Specially for the separation of enantiomers
page 290

Accessories for particulate HPLC columns:

▶ **manu-CART® cartridge holder** for LiChroCART® cartridges
page 296

▶ **LiChroCART® cartridge**
Different lengths, different internal diameter
page 299

▶ **Hibar® column**
page 301

Characterization of chiral HPLC columns

The separation of enantiomers by chiral HPLC has proven to be a most useful method for the analysis of numerous different chiral substances.

Of greatest importance is the separation of chiral drugs. Many drugs are administered as racemates. For some chiral drugs, the desired pharmacological effect is almost entirely due to one enantiomer while its other optical isomer may be responsible for significant undesirable side effects. The administration of only optical highly purified drugs is the major goal of pharmaceutical industry, to protect the patient against side-effects, caused by too high drug concentration or against toxic side effects. Chiral HPLC is a very efficient method for the separation of racemic drugs, to control the optical purity and is also a method for the preparation of optical pure drugs. Chiral HPLC is also a valuable tool for the enantioseparation of agrochemicals or flavour compounds.

Enantiomers may confer benefits over racemates for therapeutic uses

Properties of racemate	Potential benefits of enantiomers
One enantiomer is exclusively active	Reduced dose and load on metabolism
The other enantiomer is toxic	Increased latitude in dose and broader use of the drug
Enantiomers have different pharmacokinetics	Better control of kinetics and dose
Enantiomers metabolize at different rates in the same person	Wider latitude in setting the dose Reduction in variability of patient's responses
Enantiomers metabolize at different rates in the population	Reduction in variability of patient's responses Greater confidence in setting a single dose
One enantiomer prone to interaction with key detoxification pathways	Reduced interactions with other common drugs
One enantiomer is agonist, the other antagonist	Enhanced activity and reduction of dose
Enantiomers vary in spectra of pharmacological action and tissue specificity	Increased specificity and reduced side effects for one enantiomer, use of other enantiomer for different indication

ChiraDex[®]

Specially for the separation of enantiomers

ChiraDex[®] is a versatile HPLC column characterized by broad enantioselectivity and can be used for the separation of enantiomers of numerous different classes of substances.

ChiraDex[®] is based on beta-cyclodextrin covalently linked to spherical particles of silica and is well suited for the chiral separation of hydrocarbons, steroids, phenol esters and derivatives, aromatic amines, heterocycles with 5-membered ring to 7-membered ring. Simply composed RP-eluents can be used in most separations.

β-cyclodextrin

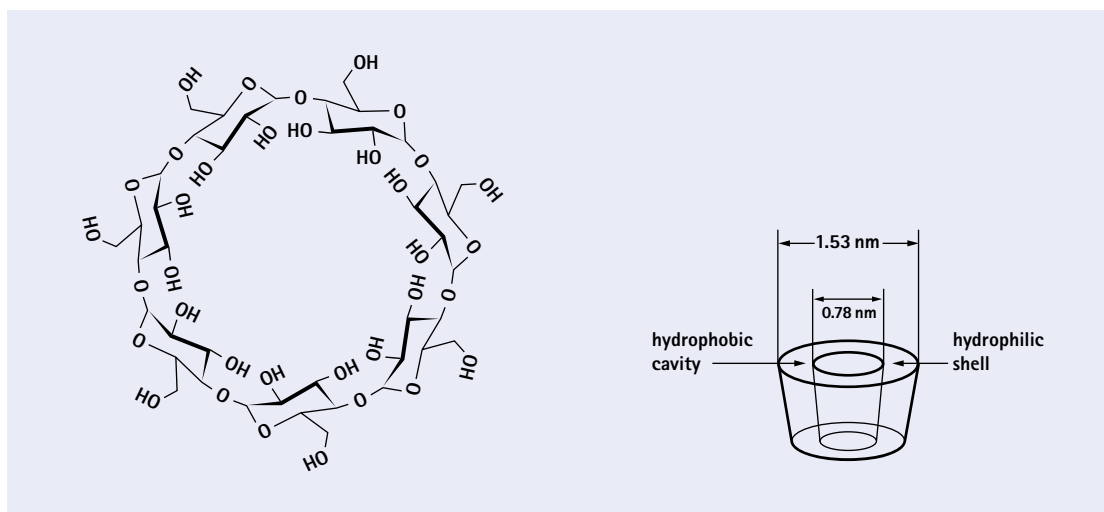

Specifications of ChiraDex[®]

Sorbent characteristics	Spherical silica particles with covalently bonded beta-cyclodextrin particles
Particle shape	spherical
Particle size	5 μm
Pore size	10 nm (100 Å)
Spec. surface area	300 - 360 m ² /g
Chiral selector	Beta-cyclodextrin
pH range	pH 3 - 7.5
Shipping eluent	Methanol/Water

Accessories for particulate HPLC columns:

► manu-CART[®] cartridge holder for LiChroCART[®] cartridges

page 296

► LiChroCART[®] cartridge
Different lengths, different internal diameter

page 299

Characterization of ChiraDex®

ChiraDex® is characterized by broad enantioselectivity and can be used for the separation of enantiomers of numerous different classes of substances. Cyclodextrins are cyclic oligosaccharins consisting of α -1,4-glycosidically linked D-glucose units. β -cyclodextrin consist of 7 glucose units, respectively. Geometrically seen, cyclodextrins may be described as truncated cones, where all the secondary hydroxy groups are directed towards the larger opening, whereas the smaller opening at the other end is formed by primary hydroxy groups.

Thus, a hydrophobic inner cavity results, contrasting with the two hydrophilic openings. Since cyclodextrins are made up of chiral D-glucose units, its structure may be regarded as a chiral selector. The enantiomers of a racemic substance mixture, due to their opposite configurations, can now be associated – to different degrees – with the cyclodextrin molecule. Thus, diastereomeric "inclusion complexes" are formed, based on hydrophobic interaction (between cavity and guest molecule) and stereo selective hydrogen bonds (between the C2 and C3 hydrogen groups of glucose molecules and the guest molecule).

Ordering information – ChiraDex®, stainless steel cartridges LiChroCART®

Product	Ordering No.	Particle size	Dimension length	Dimension i.d.	Contents of one package
ChiraDex®	1.50117.0001	5 μ m	4 mm	4 mm	10 pieces
ChiraDex®	1.51333.0001	5 μ m	250 mm	4 mm	1 piece
ChiraDex® HighResolution	1.51000.0001	5 μ m	250 mm	4 mm	1 piece

The LiChroCART® columns in the list above require part number 1.51486.0001 manu-CART® cartridge column holder, which can be used to hold one cartridge column with or without a 4–4 mm guard column.

Separation examples of chiral pharmaceutical active ingredients on ChiraDex®

Cromakalim

Column	LiChroCART® 250-4 ChiraDex®
Mobile phase	Water/Methanol 80/20 (v/v)
Flow rate	0.8 mL/min
Detection	UV 254 nm

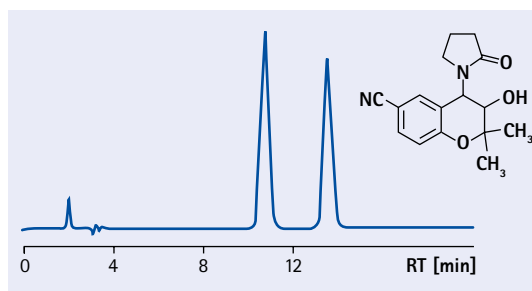

Methadone

Column	LiChroCART® 250-4 ChiraDex®
Mobile phase	Triethylammonium acetate solution (1%) pH 4.1/Acetonitrile 98/2 (v/v)
Flow rate	0.8 mL/min
Detection	UV 254 nm

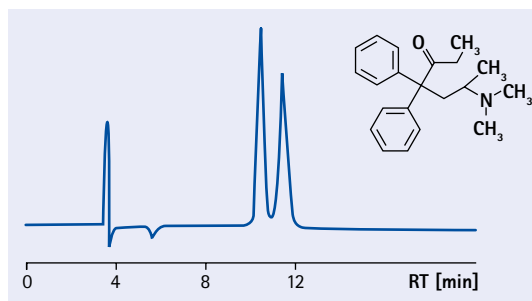

Customized packings

On top of the very extensive column assortment Merck Millipore offers customized packed columns for highest flexibility and professional solutions. Finding the right column for every separation is a tedious business. Merck Millipore, as manufacturer and supplier, can solve this problem for you – from one source. The sorbents and the packed HPLC columns are tested before delivering. The sorbents manufactured by Merck Millipore are subjected to the most stringent controls; some 42 different parameters are tested for each sorbent. Each finished column is provided with an Analysis Certificate.

▶ **Purospher® RP-18 endcapped** Excellent peak symmetry with either basic or strongly acidic compounds
page 240

▶ **Purospher® RP-18** Accelerate and simplify method development for basic compounds
page 242

▶ **Superspher®** Silica carrier for highly efficient separations
page 246

▶ **LiChrosorb®** A successful packing material from the start
page 264

▶ **LiChrospher® Si 60 and Si 100**
page 271

Accessories for particulate HPLC columns:

▶ **manu-CART® cartridge holder** for LiChroCART® cartridges
page 296

▶ **LiChroCART® cartridge** Different lengths, different internal diameter
page 299

▶ **Hibar® column**
page 301



Customized packings

Always the right column

Easy ordering: Please combine the ordering number of the column hardware [LiChroCART®, Hibar® or Eco-CART®] and the sorbent number.

Example: Customized packing ordering number of LiChroCART® 125-4 1.50170.
Sorbent number of Purospher® RP-18 HC, 5 µm 7131
Ordering number of LiChroCART® 125-4 Purospher® RP-18 HC, 5 µm 1.50170.7131

Ordering information – Customized packings, stainless steel cartridges LiChroCART®

Product	Ordering No.	Dimension length	Dimension i.d.	Packing material
LiChroCART® 10-2	1.50201.*	10 mm	2 mm	*as specified (sorbent numbers)
LiChroCART® 30-2	1.50229.*	30 mm	2 mm	*as specified (sorbent numbers)
LiChroCART® 55-2	1.50234.*	55 mm	2 mm	*as specified (sorbent numbers)
LiChroCART® 125-2	1.50195.*	125 mm	2 mm	*as specified (sorbent numbers)
LiChroCART® 250-2	1.50190.*	250 mm	2 mm	*as specified (sorbent numbers)
LiChroCART® 30-3	1.50233.*	30 mm	3 mm	*as specified (sorbent numbers)
LiChroCART® 55-3	1.50236.*	55 mm	3 mm	*as specified (sorbent numbers)
LiChroCART® 125-3	1.50175.*	125 mm	3 mm	*as specified (sorbent numbers)
LiChroCART® 250-3	1.50177.*	250 mm	3 mm	*as specified (sorbent numbers)
LiChroCART® 4-4	1.50173.*	4 mm	4 mm	*as specified (sorbent numbers)
LiChroCART® 25-4	1.50172.*	25 mm	4 mm	*as specified (sorbent numbers)
LiChroCART® 30-4	1.50302.*	30 mm	4 mm	*as specified (sorbent numbers)
LiChroCART® 55-4	1.50228.*	55 mm	4 mm	*as specified (sorbent numbers)
LiChroCART® 75-4	1.50171.*	75 mm	4 mm	*as specified (sorbent numbers)
LiChroCART® 125-4	1.50170.*	125 mm	4 mm	*as specified (sorbent numbers)
LiChroCART® 250-4	1.50174.*	250 mm	4 mm	*as specified (sorbent numbers)
LiChroCART® 100-4.6	1.51448.*	100 mm	4.6 mm	*as specified (sorbent numbers)
LiChroCART® 125-4.6	1.51442.*	125 mm	4.6 mm	*as specified (sorbent numbers)
LiChroCART® 150-4.6	1.51432.*	150 mm	4.6 mm	*as specified (sorbent numbers)
LiChroCART® 250-4.6	1.51431.*	250 mm	4.6 mm	*as specified (sorbent numbers)
LiChroCART® 10-10	1.50178.*	10 mm	10 mm	*as specified (sorbent numbers)
LiChroCART® 75-10	1.51449.*	75 mm	10 mm	*as specified (sorbent numbers)
LiChroCART® 100-10	1.51445.*	100 mm	10 mm	*as specified (sorbent numbers)
LiChroCART® 125-10	1.51443.*	125 mm	10 mm	*as specified (sorbent numbers)
LiChroCART® 150-10	1.51444.*	150 mm	10 mm	*as specified (sorbent numbers)
LiChroCART® 250-10	1.50179.*	250 mm	10 mm	*as specified (sorbent numbers)

The LiChroCART® columns (75, 125, 150 and 250 mm length) in the list above (2, 3, 4 and 4.6 mm i.d.) require part number 1.51486.0001 manu-CART® cartridge column holder, which can be used to hold one cartridge column with or without a 4-4 mm guard column. LiChroCART® columns 250-10 mm require part number 1.51419.0001 manu-CART® 10. The short LiChroCART® columns (30 and 55 mm length) can be ordered as a set including the corresponding cartridge holder and one cartridge, or as a pack of 3 cartridges without cartridge holder. The separate part numbers for the cartridge are as follows: 1.50227.0001 LiChroCART® cartridge holder for 30 mm cartridge and 1.50226.0001 LiChroCART® cartridge holder for 55 mm cartridge.



LiChroCART® cartridges 2, 3, 4 and 4.6 mm i.d. and 75, 125 and 250 mm length



manu-CART® NT cartridge holder for LiChroCART® cartridges 2, 3, 4 and 4.6 mm i.d. and 75, 100, 125, 150 and 250 mm length

Customized packings

Hibar® column 2, 3, 4 and 4.6 mm i.d. and customized packing 4.6 mm i.d.



Ordering information – Customized packings, stainless steel columns Hibar®

Product	Ordering No.	Dimension length	Dimension i.d.	Packing material
Hibar® 250-3	1.00423.*	250 mm	3 mm	*as specified (sorbent numbers)
Hibar® 30-4	1.51196.*	30 mm	4 mm	*as specified (sorbent numbers)
Hibar® 125-4	1.50181.*	125 mm	4 mm	*as specified (sorbent numbers)
Hibar® 250-4	1.50182.*	250 mm	4 mm	*as specified (sorbent numbers)
Hibar® 100-4.6	1.50013.*	100 mm	4.6 mm	*as specified (sorbent numbers)
Hibar® 125-4.6	1.50012.*	125 mm	4.6 mm	*as specified (sorbent numbers)
Hibar® 150-4.6	1.50009.*	150 mm	4.6 mm	*as specified (sorbent numbers)
Hibar® 250-4.6	1.00424.*	250 mm	4.6 mm	*as specified (sorbent numbers)
Hibar® 250-10	1.50183.*	250 mm	10 mm	*as specified (sorbent numbers)

The Hibar® columns are complete with endfittings. When using a guard column with a Hibar® column, we recommend part number 1.51487.0001 guard column cartridge holder for 4–4 mm guard column cartridges LiChroCART®.

Ordering information – Customized packings, glass cartridges EcoCART®

Product	Ordering No.	Dimension length	Dimension i.d.	Packing material
EcoCART® 125-3	1.50180.*	125 mm	3 mm	*as specified (sorbent numbers)

EcoCART® glass cartridges require part number 1.51207.0001 EcoCART® glass cartridge holder.

Ordering information – Customized packings, LiChroCART® Validation kits for LiChrospher® 60 RP-select B and LiChrospher® 100 RP-18

Product	Ordering No.	Packing material
LiChroCART® 125-3 Validation kit customized packing	1.50417.*	3 HPLC cartridges from 3 batches
LiChroCART® 250-3 Validation kit customized packing	1.50418.*	
LiChroCART® 125-4 Validation kit customized packing	1.50419.*	
LiChroCART® 250-4 Validation kit customized packing	1.50420.*	
LiChroCART® 125-4.6 Validation kit customized packing	1.50421.*	
LiChroCART® 150-4.6 Validation kit customized packing	1.50422.*	
LiChroCART® 250-4.6 Validation kit customized packing	1.50423.*	

Validation kits only available for sorbent number *7093 and *7079

Ordering information – Nucleosil® sorbent, stainless steel cartridges LiChroCART®

Product	Ordering No.	Particle size	Dimension length	Dimension i.d.	Contents of one package
Nucleosil® 100 C18	1.51324.0003	5 µm	4 mm	4 mm	10 pieces
Nucleosil® 100 C18	1.51329.0003	5 µm	125 mm	4 mm	1 piece
Nucleosil® 100 C18	1.51388.0003	5 µm	250 mm	4 mm	1 piece
Nucleosil® 100 C18	1.51378.0003	10 µm	250 mm	4 mm	1 piece

The LiChroCART® columns (125, 150 and 250 mm length) in the list above (4.6 mm i.d.) require part number 1.51486.0001. manu-CART® cartridge column holder, which can be used to hold one cartridge column with or without a 4–4 mm guard column. Nucleosil® is a trademark of Macherey-Nagel, Düren.

Ordering information – Sorbents

Product	Sorbent No.	Product	Sorbent No.
Purospher® STAR		LiChrospher®	
Purospher® STAR RP-18 endcapped, 3 µm	*.7184	LiChrospher® Si 60, 5 µm	*.7109
Purospher® STAR RP-18 endcapped, 5 µm	*.7185	LiChrospher® Si 60, 10 µm	*.7104
Purospher® STAR RP-18 endcapped, 10 µm	*.7186	LiChrospher® Si 60, 12 µm	*.7106
Purospher® STAR RP-8 endcapped, 3 µm	*.7220	LiChrospher® Si 60, 15 µm	*.7098
Purospher® STAR RP-8 endcapped, 5 µm	*.7194	LiChrospher® Si 60, 25 µm	*.7096
Purospher® STAR NH ₂ , 5 µm	*.7177	LiChrospher® Si 100, 5 µm	*.7110
Purospher® STAR Si, 3 µm	*.7174	LiChrospher® Si 100, 10 µm	*.7101
Purospher® STAR Si, 5 µm	*.7175	LiChrospher® Si 100, 15 µm	*.7100
Purospher® RP-18 endcapped		LiChrospher® Si 100, 25 µm	*.7097
Purospher® RP-18 endcapped, 5 µm	*.7130	LiChrospher® 100 CN, 5 µm	*.7071
Purospher® RP-18 endcapped, 10 µm	*.7207	LiChrospher® 100 CN, 10 µm	*.7070
Purospher® RP-18		LiChrospher® 100 DIOL, 5 µm	*.7075
Purospher® RP-18, 5 µm	*.7127	LiChrospher® 100 DIOL, 10 µm	*.7073
Purospher® Si, 3 µm	*.7179	LiChrospher® 100 NH ₂ , 5 µm	*.7076
Purospher® Si, 5 µm	*.7180	LiChrospher® 100 NH ₂ , 10 µm	*.7077
Purospher® RP-18 HC		LiChrospher® 100 RP-8, 5 µm	*.7087
Purospher® RP-18 HC	*.7131	LiChrospher® 100 RP-8, 7 µm	*.7089
Superspher®		LiChrospher® 100 RP-8, 10 µm	*.7088
Superspher® 60 Si, 4 µm	*.7142	LiChrospher® 100 RP-8 endcapped, 5 µm	*.7092
Superspher® 100 Si, 4 µm	*.7143	LiChrospher® 100 RP-8 endcapped, 10 µm	*.7091
Superspher® 60 RP-8, 4 µm	*.7139	LiChrospher® 60 RP-select B, 5 µm	*.7093
Superspher® 60 RP-8 endcapped, 4 µm	*.7140	LiChrospher® 60 RP-select B, 10 µm	*.7094
Superspher® 60 RP-select B, 4 µm	*.7141	LiChrospher® 60 RP-select B, 15 µm	*.7209
Superspher® 100 RP-18, 4 µm	*.7137	LiChrospher® 60 RP-select B, 25 µm	*.7095
Superspher® 100 RP-18 endcapped, 4 µm	*.7138	LiChrospher® 100 RP-18, 5 µm	*.7079
LiChrosorb®		LiChrospher® 100 RP-18, 7 µm	*.7080
LiChrosorb® Si 100, 10 µm	*.7063	LiChrospher® 100 RP-18, 10 µm	*.7081
LiChrosorb® RP-8, 5 µm	*.7057	LiChrospher® 100 RP-18, 12 µm	*.7208
LiChrosorb® RP-8, 10 µm	*.7059	LiChrospher® 100 RP-18, 15 µm	*.7206
LiChrosorb® RP-18, 5 µm	*.7052	LiChrospher® 100 RP-18 endcapped, 5 µm	*.7085
LiChrosorb® RP-18, 10 µm	*.7054	LiChrospher® 100 RP-18 endcapped, 10 µm	*.7084
Aluspher®		LiChrospher® 100 PAH, 5 µm	*.7078
Aluspher® 100 RP-select B, 5 µm	*.7002	LiChrospher® 300 WP RP-18, 5 µm	*.7116
		LiChrospher® 300 WP RP-18, 12 µm	*.7114
		LiChrospher® 300 WP RP-18, 15 µm	*.7115
		LiChrospher® 300 WP RP-18 endcapped, 5 µm	*.7117
		Chiral HPLC sorbents	
		ChiraDex®, 5 µm	*.7004

manu-CART[®] cartridge holder for LiChroCART[®] cartridges

Accessories for particulate HPLC columns

The "one-turn" cartridge system for simple, rapid "hands only" fitting of cartridges and precolumns. manu-CART[®] cartridge holder for the LiChroCART[®] cartridge system are ingenious. They are re-usable and fit every cartridge length with different internal diameter. And a simple turn per-mits an easy and problem-free integration of a guard cartridge. For coupling of two LiChroCART[®] cartridges a coupling unit can be used and for connecting a LiChroCART[®] HPLC cartridge with a LiChroCART[®] 25-4 pre-cartridge the coupling kit. The manu-CART[®] cartridge holder fits for 2, 3, 4 and 4.6 mm i.d. LiChroCART[®] cartridges and 75, 100, 125, 150 and 250 mm length



Pressure cone for manu-CART[®] cartridge holder
1.51258

LiChroCART[®] HPLC cartridge (i.d. 2, 3, 4 and 4.6 mm) and LiChroCART[®] 4-4 (or 10-2)
HPLC guard cartridge with manu-CART[®] NT 1.51486

Selection of manu-CART[®] cartridge holder

Cartridge holder	Ordering No.	LiChroCART [®] cartridge
manu-CART [®] 25 mm	1.50017.0001	25-4 and 25-2
manu-CART [®] 30 mm	1.50227.0001	30-2, 30-3 and 30-4
manu-CART [®] 55 mm	1.50226.0001	55-2, 55-3 and 55-4
manu-CART [®] NT	1.51486.0001	75-4
manu-CART [®] NT	1.51486.0001	100-4.6
manu-CART [®] NT	1.51486.0001	125-2, 125-3, 125-4 and 125-4.6
manu-CART [®] NT	1.51486.0001	150-4.6
manu-CART [®] NT	1.51486.0001	250-2, 250-3, 250-4 and 250-4.6
manu-CART [®] 10-II	1.51419.0001	75-10, 100-10, 125-10, 150-10 and 250-10

manu-CART® cartridge holder for LiChroCART® cartridges

Ordering information – manu-CART® cartridge holder, manu-CART® endfittings for stainless steel cartridges LiChroCART®

Product	Ordering No.	Contents of one package
manu-CART® NT cartridge holder for 2, 3, 4 and 4.6 mm i.d. LiChroCART® cartridges	1.51486.0001	2 complete stainless steel units for mounting one LiChroCART® cartridge
manu-CART® "10" II cartridge holder for 10 mm i.d. LiChroCART® cartridges	1.51419.0001	2 complete stainless steel units for mounting one LiChroCART® cartridge
manu-CART® coupling kit for coupling with LiChroCART® 25-4 pre-cartridge	1.50082.0001	1 coupling unit 1 endfitting for LiChroCART® 25-4
manu-CART® coupling unit to connect two LiChroCART® cartridges	1.50083.0001	1 piece
manu-CART® holder 25-4 and 25-2	1.50017.0001	1 piece
manu-CART® holder 30 mm for 30-2, 30-3 and 30-4 LiChroCART® cartridges	1.50227.0001	1 piece
manu-CART® holder 55 mm for 55-2, 55-3 and 55-4 LiChroCART® cartridges	1.50226.0001	1 piece
Pressure cone for manu-CART® endfitting	1.51258.0001	2 pieces
Split collets for manu-CART® endfitting	1.51257.0001	4 pieces



*manu-CART® holder 30 mm [1.50227]
for LiChroCART® 30-4, 30-3 and 30-2*



*manu-CART® holder 55 mm [1.50226]
for LiChroCART® 55-4, 55-3 and 55-2*

Mounting of patented manu-CART® endfittings nothing could be simpler

Mounting with guard cartridge 4-4 or 10-10

1. Slide sleeve over cartridge.
2. Fix split-collets in the groove in direction of the guard cartridge. Apply guard cartridge with its cone in direction of the main cartridge, slide sleeve on top and fasten with cap nut.

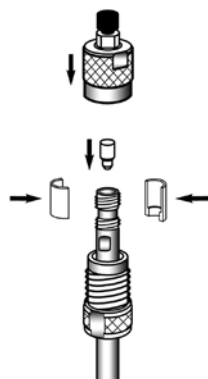

Mounting without guard cartridge

1. Slide sleeve with external thread over cartridge.
2. Using your finger, hold one split-collet at the groove. Apply the second split-collet, slide sleeve over it and fasten with cap nut.

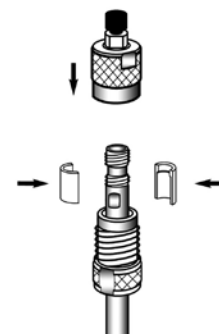

What can also be connected to manu-CART®?

manu-CART® NT cartridge holder [1.51486.0001] for LiChroCART® cartridge of 75, 100, 125, 150 and 250 mm length and 2, 3, 4 and 4.6 mm i.d.

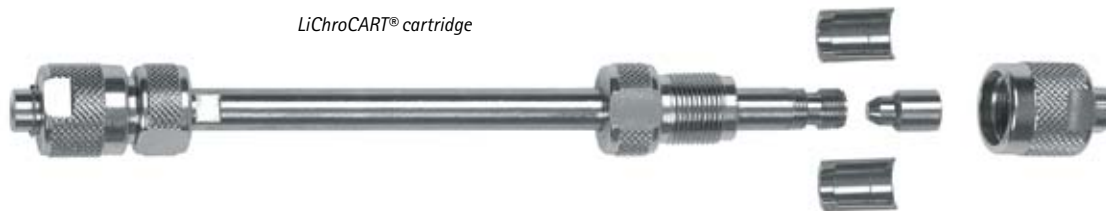

Use of LiChroCART® 4-4 or 10-2 guard cartridges with manu-CART® NT



Coupling two LiChroCART® HPLC cartridges (of 75, 100, 125, 150 and 250 mm length) with coupling unit [1.50083]



Connecting a LiChroCART® HPLC cartridge with a LiChroCART® 25-4 and 25-2 pre-cartridge with coupling kit [1.50082]



Mounting a LiChroCART® 25-4 and 25-2 pre-cartridge with endfitting [from 1.50082] and cap nut [from 1.51486]

LiChroCART[®] cartridge

Accessories for particulate HPLC columns

The LiChroCART[®] cartridge – different lengths, different internal diameter

With LiChroCART[®] cartridges the user works with re-usable endfittings which fit different cartridge lengths. Since these cartridge holders may remain in the system and the capillary connections do not need to be detached, the cartridges may be changed within the shortest possible time. Changing a separation cartridge from a length of 125 to 250 mm and back presents no problems. Furthermore, the adaptation of internal diameter (3 mm or 2 mm) to the analysis problem is possible within a few minutes. The endfittings are designed to allow the cartridges to be hand-sealed at normal working pressures of 150 to 200 bar without the need for any tools. Only at higher pressures may further tightening with a wrench become necessary.



*manu-CART[®] NT cartridge holder
for LiChroCART[®] cartridges
2, 3, 4 and 4.6 mm i.d. and 75, 100,
125, 150 and 250 mm length*

*LiChroCART[®] cartridges
2, 3, 4 and 4.6 mm i.d. and 75,
125 and 250 mm length*



Ordering information – Accessories for stainless steel cartridges LiChroCART[®]

Product	Ordering No.	Contents of one package
LiChroCART [®] frit elements for 4 mm and 4.6 mm i.d. cartridges	1.51496.0001	10 stainless steel frits with PFA ring seals 10 glass fibre filters*
LiChroCART [®] frit elements for 2 mm and 3 mm i.d. cartridges	1.51195.0001	10 stainless steel frits with PFA ring seals 10 glass fibre filters* (tool 1.15576.0001 not included)
LiChroCART [®] Assembly tool for replacement of frits 2, 3, 4 and 4.6 mm i.d	1.15576.0001	1 centering sleeve 1 assembly tool 1 tool for replacement of sealing rings from LiChroCART [®] cartridges

Pore size of filters: 2 µm | * Assembly tool 1.15576.0001 not included



*Tool for replacement
of sealing rings
and ring seals with frits*

Cartridges save costs

The HPLC cartridge is a sorbent-filled stainless steel tube closed at both ends by a filter element and fitted with a groove for the holding device. No threads are necessary. The connection pieces can be used over and over again. The cartridge is therefore more economical and in the long run the right concept for reducing analysis costs. Cartridge kits containing the cartridge, the holding devices and a precolumn, allow for a favorably priced start in the HPLC technique. This technology becomes uniquely advantageous by the use of statistically tested cartridges for the most frequently used RP-chromatography applications. Optimum control of the packing process is decisive in this case. Batch size, automation and packing technology for today's RP-materials have reached a standard permitting random testing. The reversed-phase cartridges offered in favorably priced 3-packs are the work horses of chromatography.

A package LiChroCART®
4x4 mm precolumns



Cartridges with precolumns have longer lives

The flexibility of the cartridge system becomes obvious in the integration of precolumns. Without the need for additional precolumn holders and capillaries, 4x4 mm precolumns may be integrated into the system practically void volume-free. A simple turn of the split collets holding the cartridges in the fitting suffices. A precolumn change also presents no problems. In this way, the lifetime of the separation cartridge may be extended simply and cost-effectively.

Exchanging the sieve and glass fiber filter of LiChroCART® cartridges [using assembly tool]

1. Remove the manu-CART® "4" endfitting. Put them aside for re-use later. Screw the mini cork-screw tool into the PTFE ring and pull gently to remove the filter (A).
2. In case of a PFA filter take the stainless steel core in addition to guide the screw tool.
3. Using a small spatula remove the remains of the glass fiber filter and any soiled packing material. Fill the void with freshly prepared packing material and smooth off the surface. Place a new filter on the top of the cartridge. Use the broad end of the plastic tool to push the filter into the cartridge (B).
4. Place a PTFE sealing element into the open end of the cartridge and press it firmly into its place by using the narrow end of the plastic tool and the plastic core for guiding (C).
5. In case of a PFA element take the new plastic tool to have more power.
6. Reassemble the manu-CART® endfitting and re-equilibrate the column.

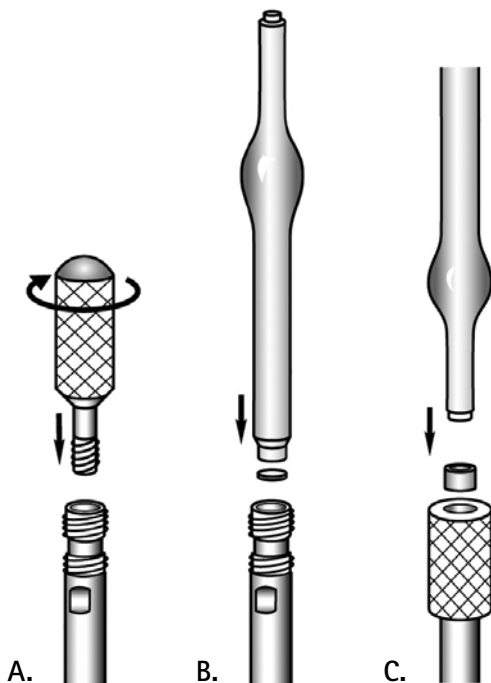

Hibar® column

Accessories for particulate HPLC columns

The traditional heart of HPLC is the "ready-to-use" column with threads at both ends onto which reducers for capillary connection are screwed. As a rule, precolumns are coupled with the main column via capillaries. If the column is exhausted, the user has two possibilities: Refilling, provided aggressive eluents do not prevent this by causing corrosion or worn threads, or the whole column is discarded. Column refilling without tube revision is problematic in view of GLP since each column has a different "history" and a different pretreatment for each new assignment.



Hibar® column
Purospher® STAR 2, 3, 4 and 4.6 mm i.d.
and customized packing 4.6 mm i.d.

Ordering information – Guard column holder for Hibar® columns

Product	Ordering No.	Contents of one package [see figure on next 2 pages]
Precolumn holder for 4-4 LiChroCART® cartridges for capillary connection to Hibar® column	1.16217.0001	1 piece
Precolumn holder for 4-4 LiChroCART® cartridges for direct coupling to Hibar® column	1.51487.0001	1 piece
Precolumn holder for 4-4 LiChroCART® cartridges for direct coupling to Hibar® column	1.16333.0001	1 piece

Ordering information – Tools for Hibar® columns

Product	Ordering No.	Dimension i.d.	Packing material
Hibar® replacement frits with PTFE sealing rings	1.51211.0001	4 mm	3 pieces
Hibar® replacement frits with PTFE sealing rings	1.51220.0001	10 mm	3 pieces
Hibar® frit extractor for removing frits from reducers	1.51210.0001	4 mm	1 piece



Hibar® frit
extractor



Hibar®
replacement frits

Mounting of LiChroCART® 4x4 mm precolumn to any analytical HPLC column

Mounting of LiChroCART® 4x4 mm precolumn to Hibar® RT analytical HPLC column for direct connection with column holder [1.51487.0001]

Precolumn holder for 4-4 LiChroCART® cartridges for capillary connection 1.16217.0001



Capillary connection

HPLC column of any supplier with precolumn LiChroCART® 4-4 connected by capillary connection with precolumn holder 1.16217.0001



Precolumn holder for 4-4 LiChroCART® cartridges for direct coupling to Hibar® RT column 1.51487.0001

Hibar® RT column with precolumn LiChroCART® 4-4 connected with precolumn holder 1.51487.0001 for direct coupling to Hibar® RT column



For coupling the precolumn holder remove endfitting

Hibar® RT column 2, 3, 4, and 4.6 mm i.d.

Mounting of LiChroCART® 4x4 mm precolumn to any analytical HPLC column with old Hibar® RT column holder [1.16333.0001] *

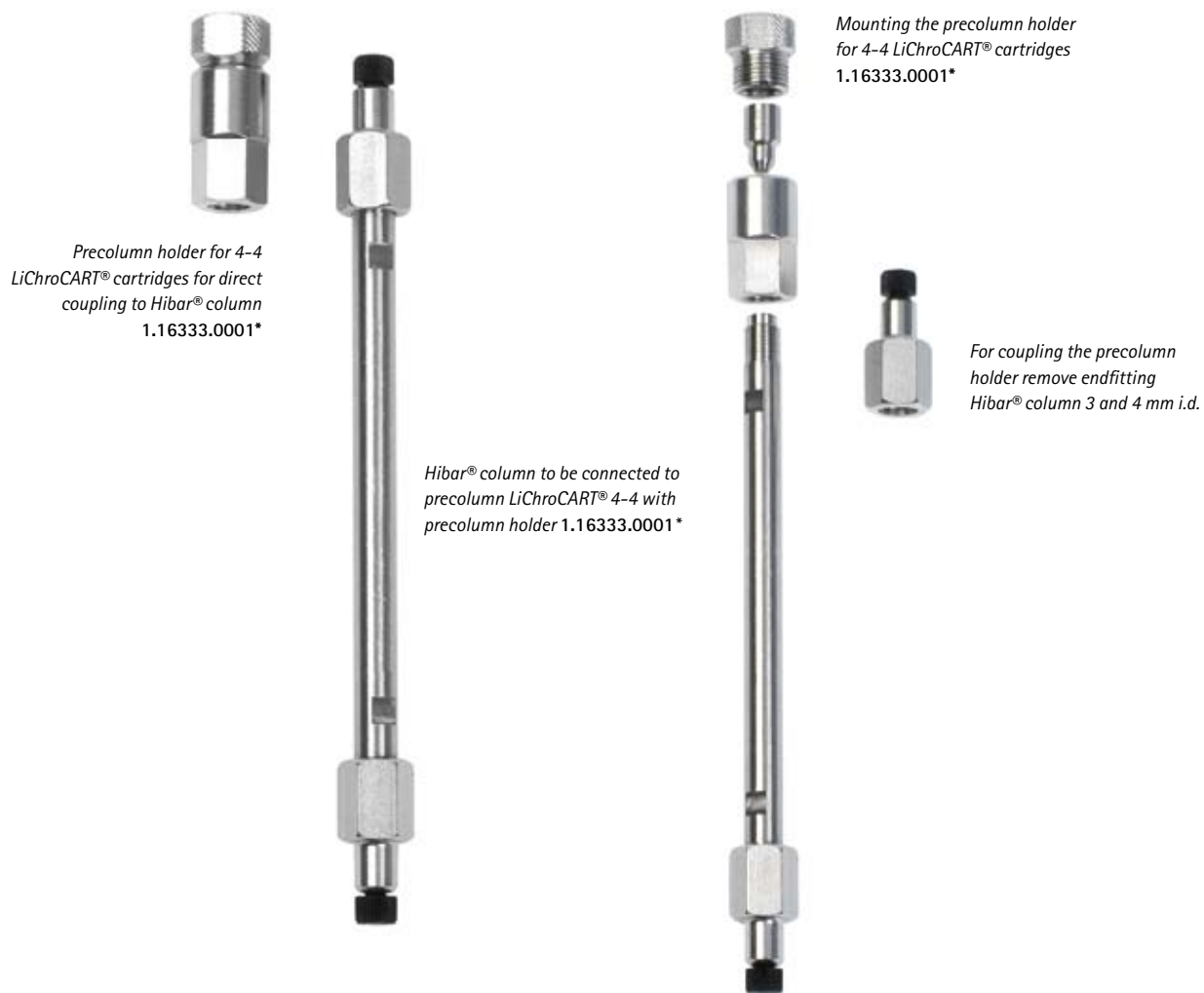

* This column is no longer available from 2011 on.



1.13171.0001



1.51214.0001



1.51213.0001

Ordering information – Hibar® / LiChroCART® kits

Product	Ordering No.	Contents of one package
HPLC Starter-Kit	1.13171.0001	4 knurled nuts for capillary connections (o.d. 1/16" or 0.5 mm) 10 PVDF double cones for capillary connections (o.d. 0.5 mm or i.d. 0.2 mm) 10 stainless steel filters with PTFE ring seal and 10 ceramic filters for HPLC cartridges LiChroCART® (i.d. 4 mm) 3 coupling units 6 pressure nuts 6 ferrules for capillaries (o.d. 1/16" or 0.5 mm) 1 capillary tubes each of 50, 80, 120 and 200 mm length 1 union (dead volume free) for capillaries (o.d. 1/16" or 0.5 mm) 8 nuts for capillary connections and 10 ferrules for capillary connection (o.d. 1/16") 3 stainless steel capillaries (o.d. 0.2 mm) 1000 mm length 2 knurled nuts (long necked) for 6-port injection valves (type Rheodyne 7125) 10 PVDF double cones for capillary connection (o.d. 1/16")
Mounting kit for capillary connection (o.d. 1/16")	1.51214.0001	1 capillary tube each (o.d.1/16", i.d. 0.25 mm) of 50, 80, 120 and 200 mm length 1 dead-volume free union for capillaries (o.d. 1/16" or 0.5 mm) 8 nuts for capillary connections (o.d. 1/16") 10 stainless steel ferrules for capillary connections
Coupling kit (dead volume-free) for capillaries (o.d. 1/16" or 0.5 mm)	1.51213.0001	3 coupling units 6 nuts 6 ferrules

Ordering information – Hibar® / LiChroCART® capillaries

Product	Ordering No.	Dimension i.d.	Contents of one package
Stainless steel capillaries (o.d. 1/16", i.d. 0.25 mm)	1.51230.0001	80 mm	10 pieces
Stainless steel capillaries (o.d. 1/16", i.d. 0.25 mm)	1.51231.0001	120 mm	10 pieces
Stainless steel capillaries (o.d. 0.5 mm, i.d. 0.20 mm)	1.15547.0001	250 mm	5 pieces
Stainless steel capillaries (o.d. 0.5 mm, i.d. 0.20 mm)	1.51236.0001	1000 mm	3 pieces
Stainless steel capillaries (o.d. 0.5 mm, i.d. 0.10 mm)	1.51247.0001	150 mm	5 pieces
Stainless steel capillaries (o.d. 0.5 mm, i.d. 0.10 mm)	1.51245.0001	1000 mm	1 piece



Ordering information – Hibar® / LiChroCART® nuts and ferrules

Product	Ordering No.	Contents of one package
Dead-volume free coupling unit for capillary connection (o.d. 1/16" or 0.5 mm)	1.51252.0001	3 units
Nuts for capillary connections (o.d. 1/16")	1.51216.0001	10 nuts
Knurled nuts for capillary connection with PVDF double cones	1.15545.0001	4 knurled nuts
Knurled nuts with long bushing for Rheodyne	1.51237.0001	2 knurled nuts 6 PVDF double cones
Ferrules for capillary connections (o.d. 1/16")	1.51217.0001	20 ferrules (cone angle 18°)
PVDF double cones for capillary tubing (1/16") with knurled screw [Fit with Ord. No. 1.15545 or 1.51216]	1.51238.0001	10 PVDF double cones
PVDF double cones for capillary connection (o.d. 0.5 mm) with knurled nuts [Fit with Ord. No. 1.15545]	1.15546.0001	10 PVDF double cones
PVDF plugs	1.51218.0001	20 PVDF plugs

1.15545.0001



1.51217.0001



1.51238.0001



1.51237.0001



1.15546.0001



LiChroTest®

Standard samples for HPLC system qualification

The quality of analytical results is principally determined by the correct functioning of the analytical instruments employed. For this reason, the various quality assurance systems as well as the FDA require analytical instruments to be subjected to periodical qualification. Therefore, before starting a series of analyses, you first should establish whether your HPLC system meets with your requirements. These "Operational Qualification" (OQ) and "Performance Qualification" (PQ) steps involve tests of the different modules on their specifications and a check on the entire system using a real application relevant to the laboratory-specific requirements. In order to facilitate this instrument qualification in the HPLC laboratory, Merck Millipore and VWR International have developed the LiChroTest® products. These enable time saving operational and performance qualification to be performed routinely and according to standardized methods.

Characterization of LiChroTest®

For both, Operational Qualification and Performance Qualification, different test samples for checking precision, accuracy, linearity and sample-carry-over of the different HPLC modules or the complete system are available. Each set contains several ampoules of sample accompanied by a Certificate of Analysis that ensures uniform quality and traceability to international standards. These test samples can be used to perform a simple and standardized check of the critical parameters of HPLC system function.

LiChroTest® PQ – Performance Qualification

For Performance Qualification, the LiChroTest® PQ, a complete test kit for 8 different system tests, is ideal. The test procedure involved has been selected and optimized to include meaningful system performance parameters and to ensure ease-of-use, time saving and extensive automation. The kit comprises an HPLC column, test samples, a description of the qualification process and the test methods as well as an example test report which are suitable for use with any HPLC system. In this way, you can rapidly and routinely carry out fully automatic performance qualification of your HPLC instruments. The documentation completed in the course of the qualification procedure is very useful for passing future audits.

The following HPLC system tests can be carried out:

- Qualification of system communication
- Qualification of data processing
- Baseline noise and drift levels
- System suitability test: Peak width and symmetry
- Repeatability: Peak area and retention time
- Linearity
- Sample carry-over
- Qualification of system control

The LiChroTest® PQ kit contains ready to use methods for the LaChrom® D-7000 HPLC System Manager software and for the EZChrom Elite chromatography data system in combination with LaChrom® and LaChrom® Elite systems. The certified standard samples contained in the LiChroTest® PQ kit are available as refill packs. Six further UV/VIS standard solutions from Merck Millipore are also available for checking photometers, spectrophotometers and UV detectors for wavelength accuracy, stray light, spectral resolution and absorption accuracy according to the European Pharmacopoeia (Ph Eur). LiChroTest® is a further contribution from VWR International and Merck Millipore towards guaranteeing the quality of your analytical results and preparing you for your next audit.

Ordering information – LiChroTest® PQ: Test Kit for HPLC System Performance Qualification

Product	Ordering No.	Description
LiChroTest® PQ	1.19156.0001	Performance qualification Kit for HPLC System Qualification Usable for all kinds of HPLC systems

Ordering information – LiChroTest® PQ: LiChroTest® Standard samples for HPLC System Performance Qualification

Product	Ordering No.	Contents of one package
LiChroTest® PQ Set 1A: Precision and Linearity (PQ)	1.19157.0001	Refill pack for the LiChroTest® PQ Kit. 1.19156.0001 Dilution series of methyl paraben in methanol/water (50/50) (concentrations 50, 100, 150, 200 mg/L)
LiChroTest® PQ Set 1: Precision and Linearity (PQ)	1.19165.0001	Refill pack for the old LiChroTest® PQ Kit. 1.15958.0001 Dilution series of methyl paraben in methanol/water (50/50) (concentrations, 1, 10, 100, 200 mg/L)
LiChroTest® PQ Set 3: Precision (PQ)	1.19158.0001	5 Standard samples of 100 mg/L methyl paraben in methanol/ water (50/50) Refill pack for the LiChroTest® PQ set
LiChroTest® PQ Set 3: Separation (Parabens) (PQ)	1.19159.0001	5 Standard samples with 3 different parabens + t_0 -marker in methanol/water (50/50), with sample chromatogram and analysis conditions

Ordering information – LiChroTest® OQ: LiChroTest® Standard samples for HPLC System Operational Qualification

Product	Ordering No.	Contents of one package
LiChroTest® OQ Set 5: Autosampler Test (OQ)	1.15201.0001	5 Standard samples with perylene in methanol for checking injection precision (OQ) of LaChrom® autosamplers
LiChroTest® OQ Set 7: Precision (OQ)	1.19161.0001	60 mg/L methyl paraben in methanol
LiChroTest® OQ Set 8: Linearity (OQ)	1.19162.0001	Dilution series of methyl paraben in methanol (concentrations: 1.5, 7.5, 15, 75, 150 mg/L)
Caffeine solution A for gradient test (OQ)	1.19163.0001	20 mg/L caffeine in water (0.5 L)
Caffeine solution B for gradient test (OQ)	1.19169.0001	20 mg/L caffeine in methanol (0.5 L)

Column care and use

Column hardware

HPLC and UHPLC columns from Merck Millipore come in a variety of different column hardware formats and materials for different applications. All columns have 10-32 UNF female end fittings that connect to 1/16" capillary tubing. Note that removing pre-installed end fittings from HPLC columns might damage the column bed and reduce performance.

Particulate silica columns for reversed phase and normal phase HPLC are delivered in stainless steel column hardware; either as ready-to-use Hibar® columns or as the LiChroCART® cartridge system comprising separately ordered, re-usable end fittings (manu-CART®). Hibar® HR columns have extra-high pressure stability and extremely small internal dead volumes, making them especially suitable for use in UHPLC instruments. Both Hibar® and LiChroCART® columns have stainless steel frits to keep the stationary phase particles in place.

Chromolith® columns are clad with a mechanically stable and chemically robust poly(ether-ether-ketone) polymer (PEEK). The end fittings are made of the same material. Chromolith® columns contain no frits.

Chromolith® CapROD® columns are of fused silica tubing and contain no frits. These columns are delivered without end fittings.

SeQuant® columns have different column hardware depending on the internal diameter. Analytical sizes (2.1, 4.6, and 7.5 mm i.d.) have PEEK hardware with PEEK frits for maximum inertness towards hydrophilic analytes. SeQuant® semi-preparative columns have stainless steel hardware and stainless steel frits. SeQuant® microbore and capillary columns (1.0 and 0.3 mm i.d.) are of glass-lined stainless steel and contain stainless steel frits. SeQuant® nano columns (100 µm and 75 µm i.d.) are of PEEK-sheeted fused silica tubing.

NB! The fused silica tubing column material of SeQuant® nano columns and Chromolith® CapROD® is brittle and should not be exposed to extensive bending as it might break.

NB! Columns in PEEK, i.e. Chromolith® and SeQuant® analytical columns, cannot be used with more than 50% tetrahydrofuran (THF), 5% dichloromethane (DCM) or 5% dimethylsulfoxide (DMSO). Such solvents can, however, be used at 100% as sample solvent.

Column hardware	Type	Body	Frit	Max. pressure	Solvent restrictions
Hibar® RT	Ready-to-use	Stainless steel	Stainless steel	400 bar	
Hibar® HR	Ready-to-use	Stainless steel	Stainless steel	600 bar	
LiChroCART®	Cartridge	Stainless steel	Stainless steel	250 bar	
Chromolith®	Ready-to-use	PEEK	-	200 bar	THF, DMSO, DCM
Chromolith® CapROD®	Ready-to-use	Fused silica	-	200 bar	
SeQuant® Analytical	Ready-to-use	PEEK	PEEK	350 bar*	THF, DMSO, DCM
SeQuant® Semi-prep	Ready-to-use	Stainless steel	Stainless steel	400 bar	
SeQuant® Capillary	Ready-to-use	Glass-lined stainless steel	Stainless steel	400 bar	
SeQuant® Nano	Ready-to-use	PEEK-sheeted fused silica	Stainless steel	400 bar	

* The maximum pressure for SeQuant® ZIC®-pHILIC columns is 200 bar due to the polymer-based particles.

Column installation

Merck Millipore HPLC and UHPLC columns are designed to fit any HPLC instrument; however, care should be taken at installation so as not to introduce dead volumes in the connections, which would reduce separation efficiency. Note that stainless steel tubing fittings are inflexible and cannot be adapted to different port designs after the first installation, whereas PEEK fittings can be adjusted for different columns several times. Also note that stainless steel fittings and ferrules can damage the end fittings of PEEK column hardware, especially if installed with excessive force by using wrench tools.

Merck Millipore columns should be installed with the flow arrow on the label pointing towards the detector. Before the column outlet is connected to the detector, it is wise to flush the column with mobile phase.

Column equilibration

Proper column equilibration is time well spent as it will give you more consistent results and reduce trouble-shooting. Verify that your mobile phase is miscible with the shipping solvent before starting to flush or equilibrate the column. Gradually increase the flow rate in small steps until it satisfies your conditions. Flush the column with your mobile phase until you obtain a stable baseline. Mobile phases with additives in low concentrations (e.g. ion-pair reagents) may require longer equilibration times.

Reversed phase columns (RP-18, RP-8) are shipped in acetonitrile/water. If the column has dried out during storage or shipping, thoroughly activate the packing by flushing with 10-20 column volumes of pure organic solvent (e.g. acetonitrile) before equilibrating the column with the mobile phase.

Normal phase columns (Si, NH₂, CN, Diol) are shipped with n-heptane/dioxane (99/1). If they are going to be used with aqueous eluents, flush the column with ethanol or 2-propanol before you equilibrate with the mobile phase.

HILIC columns (ZIC®) are shipped with acetonitrile/water (80/20) containing 5 mM ammonium acetate salt. In the event that the column has dried out, flush with 20 column volumes of water at a low flow rate before equilibrating the column with the mobile phase.

Validating column performance

Every HPLC column from Merck Millipore is delivered with a test certificate displaying its separation efficiency and selectivity at the time of manufacturing. Repeating the test periodically is a good way of following trends in performance change over time. Please note that the test instruments have been optimized so as not to be significantly affected by external sources of band broadening, and that things might be different in your system. For optimum separation efficiency minimize the injection volume, detector volume, capillary tubing length, internal diameter and detector response time.

Fast chromatographic peaks from Chromolith®, Purospher® STAR UHPLC and SeQuant® ZIC®-HILIC columns can be just a few seconds wide. Note that for accurate representation of a chromatographic peak the data system needs to enable approximately 20 data points to be acquired during the peak width time.

Mobile phases

Merck Millipore's silica-based particulate HPLC columns in stainless steel hardware are compatible with all organic solvents in pH range mentioned in the table below. However, a few restrictions on the use of THF, DCM and DMSO apply to columns in PEEK hardware (i.e. Chromolith® and SeQuant®), see table above.

For best results, high-quality solvents such as HPLC-grade LiChrosolv® should be used. All prepared buffers should be filtered through a 0.45 µm filter (0.22 µm for UHPLC columns) before use in the HPLC system. Always keep in mind that your column will collect any particulate material that enters the flow stream. The use of non-pure solvents will result in adsorption of impurities on the column head. These impurities block adsorption sites, change the selectivity of the column and lead to peak splitting in the chromatogram. In gradient elution, impure solvents may result in ghost peaks that always appear at the same position in the chromatogram.

Any type of buffer, organic modifier and paired-ion reagent will be compatible with Merck Millipore's HPLC columns as long as the appropriate pH range is not exceeded. Verify that solvents are miscible when changing mobile phases and that no buffer precipitation will occur. Ion-pair reagents are often difficult to flush completely from the column and columns used with these reagents should be dedicated to the particular analysis involved. Ion-pair reagents are also known to reduce sensitivity in mass spectrometry detection.

NB! Ion-pair reagents are not suitable for HILIC columns since they will make the stationary phase less polar and thus diminish retention.

NB! The limited solubility of some buffers (e.g. phosphate) in organic solvents may limit their use in HILIC separations and precautions should thus be taken to avoid precipitation problems.

Column lifetime

Column lifetime is highly dependent on the sample and conditions, and cannot be generalized upon; however, you can apply some general measures to increase the lifetime of the column.

Make sure that your sample and mobile phase are clean and particle-free. Always degas and filter mobile phases. Clean up your sample prior to analysis using filtration or more advanced sample preparations if your sample contains large amounts of contaminants. The use of guard columns is always recommended for real samples.

Pressure stability

Pressure limits for different column formats are listed in the table above. All stationary phases are specified to the same or higher pressures than the hardware except for polymer-based SeQuant® ZIC®-pHILIC, which is pressure-stable up to 200 bar.

pH stability

Silica-based stationary phases have a limited pH stability. A pH higher than the limit will dissolve the silica, creating voids in the column. A lower pH can strip away some of the bonded phase resulting in defects that will cause changes in retention times and loss of resolution. pH stability ranges for stationary phases from Merck Millipore are presented in the table below.

Do not use strong acids (e.g. hydrochloric, nitric, and sulfuric acids) in the column. Limit your use of strong bases (e.g. sodium, potassium, ammonium hydroxide) to amounts needed to adjust the pH of the mobile phase. When measuring the pH of mobile phases, the measurement should be done in the aqueous media before mixing the eluent with organic solvents. Although this will not give the actual pH in the mixed aqueous-organic solvent, it will give more consistent results than a mixed mobile phase.

Stationary phase	pH stability range	Max. temperature
LiChrospher®	2-7.5	60°C
Superspher®	2-7.5	60°C
LiChrosorb®	2-7.5	60°C
Chromolith®	2-7.5	45°C
Purospher®	2-8	65°C
Purospher® STAR RP-18e and RP-8e	1.5-10.5	65°C
SeQuant® ZIC®-HILIC	2-8	70°C
SeQuant® ZIC®-pHILIC	2-12	50°C
Aluspher® RP-select B	2-12	30°C

Temperature stability

The maximum operating temperatures are stated in the table above. To avoid band broadening and loss of separation efficiency the mobile phase should always be kept at the same temperature as the column. This can be done either through the use of active heaters or by passive heating using a short piece of capillary tubing within the column oven.

Storing the column

For short-term storage (overnight), HPLC columns can be stored in the eluent. Always confirm that the column end plugs are firmly in place, regardless of how long the column will be stored. When columns are stored for several days or longer, reversed-phase columns should be stored in an organic solvent, preferably acetonitrile, containing less than 50% water and no buffer. Purospher® STAR RP-8 endcapped and Purospher® STAR RP-18 endcapped columns are best stored in 100% acetonitrile. If you are changing storage solvent and your last reversed-phase mobile phase contained buffer salt, flush the column with 10 column volumes of water before storing in organic eluent. Buffer salts might not be soluble in high concentrations of organic solvent and might precipitate and block the column or capillary tubing.

Separation mode	Phases	Short-term storage	Long-term storage
RP [reversed-phase]	<ul style="list-style-type: none"> • LiChrosorb® RP-8, RP-18, (Diol, CN, NH₂)* • LiChrospher® RP-8, RP-18, (Diol, CN, NH₂)* • Purospher® STAR RP-8e, RP-18e, (NH₂)* 	Mobile phase	Acetonitrile or acetonitrile in water (< 50%)
NP [normal phase]	<ul style="list-style-type: none"> • LiChrosorb® Si, Diol, CN, NH₂ • LiChrospher® Si, Diol, CN, NH₂ • Purospher® STAR Si, NH₂ • Chromolith® Si 	Mobile phase	n-Heptane or similar organic solvent
HILIC [hydrophilic interaction]	<ul style="list-style-type: none"> • SeQuant® ZIC®-HILIC • SeQuant® ZIC®-pHILIC 	Mobile phase	80% acetonitrile in water or dilute buffer

* When used in RP mode.

Column regeneration

Exposure of a column to samples or solvents containing highly adsorptive components will result in increased back-pressure and a change in selectivity. Often the column can be restored to original performance by suitable wash protocols. When performing solvent rinse regeneration, the column should be reversed and transferred from the analytical HPLC system to a simple, inexpensive pump. Alternatively, disconnect the column from the detector and rinse directly to waste. Each solvent should be rinsed with a minimum of 20, preferably 30, column volumes.

Separation mode	Phases	Wash sequence	Comments
RP [reversed-phase]	<ul style="list-style-type: none"> • LiChrosorb® RP-8, RP-18, (Diol, CN, NH₂)* • LiChrospher® RP-8, RP-18, (Diol, CN, NH₂)* • Purospher® STAR RP-8e, RP-18e, (NH₂)* 	<ul style="list-style-type: none"> • Water • Acetonitrile • 2-Propanol + 0.1% formic acid • Heptane • 2-Propanol + 0.1% formic acid • Acetonitrile • Mobile phase 	* When used in RP mode.
NP [normal phase]	<ul style="list-style-type: none"> • LiChrosorb® Si, Diol, CN, NH₂ • LiChrospher® Si, Diol, CN, NH₂ • Purospher® STAR Si, NH₂ • Chromolith® Si 	<ul style="list-style-type: none"> • Heptane • Chloroform • Ethanol or 2-propanol • Chloroform • Heptane • Mobile phase 	Sequence of dry solvents
HILIC [hydrophilic interaction]	<ul style="list-style-type: none"> • SeQuant® ZIC®-HILIC • SeQuant® ZIC®-pHILIC 	<ul style="list-style-type: none"> • Water** • 0.5 M NaCl or another salt • Water • Mobile phase 	** Double the initial water rinse

Calculation of column void time

Knowledge of the void time t_m is important for the calculation of chromatographic parameters like k and u . The void time may be calculated from the volume of the empty column V_{empty} , the volume flow f_c and the porosity of the carrier material. The total porosity of a column is the volume fraction occupied by the mobile phase.

$$e = V_m / V_{\text{empty}}$$
$$t_m = V_{\text{empty}} e / f_c$$

For totally porous materials like silica and modified silica, e is between 0.7 and 0.8. The void time may also be determined by measuring the retention time of non-retarded sample substances. Suitable substances for measuring the void time are:

Determination of column void time

Reversed-phase: UV detection: thiourea. RI detection: D_2O , CD_3OH , CD_3CN , eluent itself.

Normal phase: UV detection: benzene, tetrachloroethylene; RI detection: cyclohexane, benzene. When using very weak solvents, benzene and tetrachloroethylene may also be retained.

HILIC: toluene or naphthalene

How to use the right column

The fundamental equation for chromatographic resolution (R_s) is an aid for the selection of a suitable combination of stationary phase and column size.

$$R_s = \frac{1}{4} \left(\frac{k}{1+k} \right) \left(\frac{\alpha-1}{1+k} \right) \sqrt{N}$$

The calculation of the individual contributions under different conditions shows what influence the different parameters exert. Below table shows that with the correct choice of chromatographic system, good separations can be achieved even at relative low plate numbers. On the other hand even with extremely high plate numbers a satisfactory separation can not be obtained with poor separation factors.

Individual contributions of the chromatographic resolution

$k \left(\frac{k}{1+k} \right);$	$\alpha \left(\frac{\alpha-1}{\alpha} \right);$	$N \left(\frac{\sqrt{N}}{4} \right)$	R_s for N = 1,000	R_s for N = 5,000	R_s for N = 10,000
1 (0.5)	1.05 (0.05)	1,000 (7.9)	0.20	0.4	0.6
3 (0.75)		5,000 (17.7)	0.30	0.7	0.9
5 (0.83)		10,000 (25.0)	0.33	0.7	1.0
10 (0.91)	1.1 (0.09)		0.36	0.8	1.1
1			0.36	0.8	1.1
3			0.50	1.2	1.7
5			0.60	1.3	1.9
10	1.2 (0.16)		0.65	1.4	2.0
1			0.60	1.4	2.0
3			0.95	2.1	3.0
5			1.00	2.3	3.3
10	1.3 (0.23)		1.10	2.6	3.6
1			0.90	2.0	2.9
3			1.40	3.0	4.3
5			1.50	3.4	4.8
10	1.5 (0.33)		1.60	3.7	5.2
1			1.30	2.9	4.1
3			1.90	4.4	6.2
5			2.20	4.8	6.8
10			2.40	5.3	7.5

Empty column volumes

Column [length x i.d.]	Volume	Washing volume [10 column volume]
125 x 2 mm	0.4 mL	4 mL
250 x 2 mm	0.8 mL	8 mL
125 x 3 mm	0.9 mL	9 mL
250 x 3 mm	1.8 mL	18 mL
100 x 4.6 mm	1.7 mL	17 mL
125 x 4 mm	1.6 mL	16 mL
150 x 4.6 mm	2.5 mL	25 mL
250 x 4 mm	3.2 mL	32 mL
250 x 4.6 mm	4 mL	40 mL

Trouble-Shooting

Chromatographers frequently have to identify and rectify problems which can be divided in different categories. In this chapter, we will discuss some of the most common issues that may appear and how to solve them. Emphasis is on reversed phase separation. Often problems can be avoided by routine maintenance (e.g. planned replacement of worn out parts). Simple rules defined by J.W. Dolan are useful for classifying deficiencies and can help in avoiding follow-up mistakes.

Every market research report cites the reproducibility of selectivity as the most important column criterion; hence most manufacturers have made their best at validating their production processes. Nevertheless, small differences that exist in surface chemistry tend to appear at analysis of very sensitive samples. It is virtually impossible to eliminate all these during production in view of the variables involved: crude materials and reagents, surface binding chemistry, the packing process itself as well as the column packer, laboratory equipment and environment. In addition to this, the surface chemistry tends to change during column use. The bound phase is disintegrated, silica dissolves as silicate and the extended surface tends to adsorb impurities from sample and mobile phase. Therefore, these small differences have to be compensated for by the ruggedness of the method.

Contents

Retention

Problem: Changing retention times _____	317
Problem: Decreasing retention times _____	318
Problem: Increasing retention times _____	318

Equilibration

Problem: Slow column equilibration time _____	319
Problem: Varying retention times _____	319

Peaks

Problem: Broad peaks _____	320
Problem: Ghost peaks _____	321
Problem: Negative peaks _____	321
Problem: Peak doubling _____	322
Problem: Peak fronting _____	322
Problem: Peak tailing _____	323
Problem: Spikes _____	324
Problem: No peaks _____	324
Problem: Peaks with shoulders, split peaks _____	324

Recovery

Problem: Poor sample recovery _____	325
-------------------------------------	-----

Leaks

Problem: Leak at column or fittings _____	326
Problem: Leak at detector _____	326
Problem: Leak at injection valve _____	326
Problem: Leak at pump _____	326

Selectivity

Problem: Differences in selectivity _____	326
-------------------------------------------	-----

Baseline

Problem: Disturbance at void time _____	327
Problem: Drifting baseline _____	327
Problem: Noise _____	327

Pressure

Problem: Decreasing pressure _____	328
Problem: Fluctuating pressure _____	328
Problem: High back-pressure _____	329

Retention

Small differences in mobile phase composition may cause huge differences in retention time when the column is overloaded and this also changes with temperature. However, even if the mobile phase is buffered and the pump is working properly, the retention times may fluctuate if the pH is too close to the pK of the sample substance. The pH of the mobile phase should therefore be chosen to be at least one pH unit above or below the pK value of the analytes being separated. **Retention time drift indicates insufficient column conditioning.** With increasing column life, the retention times may shift towards less retentivity, especially if the user is working at acidic pH (\leq pH 2). Abrupt changes in retention time are usually due to errors in the system.

Problem: Changing retention times

Possible cause	Solution
Flow rate variation	<ul style="list-style-type: none"> • Fix system leaks • Replace pump seals • Remove bubbles • Check for cavitations
Insufficient buffer capacity	<ul style="list-style-type: none"> • Use buffer concentration > 20 mM and < 50 mM
Column contamination build-up	<ul style="list-style-type: none"> • Flush column occasionally with strong solvent or regenerate the column
Equilibration time insufficient for gradient run or changes in isocratic mobile phase	<ul style="list-style-type: none"> • Allow at least 10 column volumes through the column for gradient regeneration or after solvent changes. True equilibration is achieved after 30 column volumes
First few injections – active sites	<ul style="list-style-type: none"> • Condition column by injecting concentrated sample
Inconsistent on-line mobile-phase mixing	<ul style="list-style-type: none"> • Ensure gradient system is delivering a constant composition • Compare with manually prepared mobile phase • Partially premix mobile phase. Avoid running from 100% pure solvent to 100% aqueous.
Selective evaporation of mobile-phase component	<ul style="list-style-type: none"> • Use closed solvent reservoirs • Use less-vigorous purging • Prepare fresh mobile phase • Check pump • Check frit • Avoid evaporation or degradation of mobile phase
Column temperature variation	<ul style="list-style-type: none"> • Thermostat or insulate column • Use column oven • Ensure constant laboratory temperature.
Column ageing	<ul style="list-style-type: none"> • Replace column • If ageing is premature, it may originate from sample matrix. Perform column regeneration • Use guard column

Problem: Decreasing retention times

Possible cause	Solution
Active sites on column packing	<ul style="list-style-type: none"> • Use mobile phase modifier • Competing base (basic compounds), or increase buffer strength • Use higher coverage column packing.
Column mass overload	<ul style="list-style-type: none"> • Decrease sample amount or use larger-diameter column
Increasing flow rate	<ul style="list-style-type: none"> • Check and reset pump flow rate.
Loss of bonded stationary phase	<ul style="list-style-type: none"> • Use mobile-phase pH that is within the specifications given for the particular column (normally between pH 2 and pH 7.5) with Purospher® STAR pH 1.5-10.5 is possible.
Column temperature variation	<ul style="list-style-type: none"> • Thermostat or insulate column • Use column oven • Ensure constant laboratory temperature.
Mobile phase composition changing	<ul style="list-style-type: none"> • Check pump • Check frit • Avoid evaporation or degradation of mobile phase
Column fouling	<ul style="list-style-type: none"> • Stationary phase modified by sample. Regenerate or change the column.

Problem: Increasing retention times

Possible cause	Solution
Decreasing flow rate	<ul style="list-style-type: none"> • Check and reset pump flow rate • Check for pump cavitations • Check for leaking pump seals and/or other leaks in system.
Changing mobile-phase composition	<ul style="list-style-type: none"> • Cover solvent reservoirs • Ensure that gradient system is delivering correct composition.
Loss of bonded stationary phase	<ul style="list-style-type: none"> • Use mobile-phase pH that is within the specifications given for the particular column (normally between pH 2 and pH 7.5). • With Purospher® STAR pH 1.5-10.5 is possible.
Mobile phase composition changing- online mixing	<ul style="list-style-type: none"> • Check pump • Check frit • Avoid evaporation or degradation of mobile phase
Failing or insufficient pH control for ionic compounds	<ul style="list-style-type: none"> • Use buffered mobile phases • Increase buffer concentration • Use buffer more suitable for required pH range
Temperature decreasing / Temperature variations in the column	<ul style="list-style-type: none"> • Use column thermostat
Column fouling	<ul style="list-style-type: none"> • Stationary phase modified by sample. Regenerate or change the column.

Equilibration

Problem: Slow column equilibration time

Possible cause	Solution
Reversed phase ion-pair reagents- long chain ion-pair reagents require longer equilibration time	<ul style="list-style-type: none"> Use ion-pair reagents with shorter alkyl chain length

Problem: Varying retention times

Possible cause	Solution
Gradient – insufficient column regeneration time	<ul style="list-style-type: none"> Increase equilibration time (volume) with initial mobile-phase composition (A) to achieve constant retention for early peaks
Ion-pair reagents- insufficient equilibration time	<ul style="list-style-type: none"> Increase equilibration time (volume) Ion-pair reagents may require as much as 50 column volumes for mobile-phase changeover
Isocratic – insufficient equilibration time	<ul style="list-style-type: none"> Pass 10-15 column volumes of mobile phase through column for equilibration

Peaks

If all peaks have same appearance in the chromatogram, the problem originated before the separation. If only some of the peaks or only one peak in the chromatogram elute with a distorted shape, the source is of chemical nature.

Problem: Broad peaks

Wide peaks are generated either by substantial influence on the part of the HPLC system (bad capillary connections, void volumes, too large detector cells or ill-chosen time constants) or by poor column performance.

Possible cause	Solution
Sample overload	<ul style="list-style-type: none"> Dilute sample 1:10 with mobile phase and re-inject
Detector-cell volume too large	<ul style="list-style-type: none"> Use smallest possible cell volume consistent with sensitivity needs Use detector with no heat exchanger in system
Injection volume too large	<ul style="list-style-type: none"> Decrease solvent strength of injection solvent to focus solute Decrease injection volume Dilute sample Rule of thumb: Inject maximum 1% of total column tube volume.
Large extra column volume	<ul style="list-style-type: none"> Use low- or zero-dead-volume end-fittings and connectors Use smallest possible diameter of connecting tubing (< 0.10 in. i.d.) Connect tubing with matched fittings
Mobile-phase solvent viscosity too high	<ul style="list-style-type: none"> Increase column temperature Change to lower viscosity solvent
Peak dispersion in injector valve	<ul style="list-style-type: none"> Decrease injector sample loop size Use segmented injection techniques (introduce air bubble in front and back of sample in loop)
Poor column efficiency	<ul style="list-style-type: none"> Use smaller-particle-diameter packing, lower-viscosity mobile phase, higher column temperature, or lower flow rate
Retention time too long	<ul style="list-style-type: none"> Use gradient elution or stronger isocratic mobile phase
Column head contaminated	<ul style="list-style-type: none"> Exchange inlet frit or filter
Fouled or worn out column	<ul style="list-style-type: none"> Regenerate column or replace with new column
Sampling rate of data system too low	<ul style="list-style-type: none"> Increase sampling frequency
Slow detector time constant	<ul style="list-style-type: none"> Adjust time constant to match peak width
Column temperature too low	<ul style="list-style-type: none"> Increase column oven temperature
Some peaks broad – late elution of analytes retained from previous injection	<ul style="list-style-type: none"> Flush column with strong solvent at end of run End gradient at higher solvent concentration
Guard column/pre-column or column defective or soiled	<ul style="list-style-type: none"> Change guard column/pre-column or column
Sample dissolved in strong solvent	<ul style="list-style-type: none"> Dissolve sample in mobile phase
Wrong buffer pH	<ul style="list-style-type: none"> Test influence of eluent pH on peak shape
Buffer concentration too low	<ul style="list-style-type: none"> Use concentrated buffer or add salt to increase total ionic strength of the mobile phase
Extra column effects	<ul style="list-style-type: none"> Check capillary connections Use shorter capillaries with smaller i.d. Check for dead-volume
Leak between column and detector.	<ul style="list-style-type: none"> Fix leak
Large detector cell	<ul style="list-style-type: none"> Use smaller cell
Sample incompatibility with system or sample precipitation	<ul style="list-style-type: none"> Use inert surfaces in system parts (injector, pump) Use simple test-tube experiment to determine solubility of sample in mobile phase to prevent on-column precipitation

Problem: Ghost peaks

Ghost peaks may be caused by unknown sample components, late eluting peaks from previous injections, impurities or mixing problems in connection with the mobile phase. The sample should therefore preferably always be dissolved in the eluent or in a solvent with weaker eluting strength. Substances with UV absorption lower than the eluent may generate negative peaks.

Possible cause	Solution
Elution of analytes retained from previous injection	<ul style="list-style-type: none"> • Flush column with strong solvent at end of run • End gradient at higher solvent concentration.
Ion-pair chromatography – upset equilibrium	<ul style="list-style-type: none"> • Prepare sample in mobile phase • Reduce injection volume
Oxidation of trifluoroacetic acid in peptide mapping	<ul style="list-style-type: none"> • Prepare trifluoroacetic acid solutions fresh daily • Use antioxidant
Unknown interferences in sample	<ul style="list-style-type: none"> • Use sample cleanup or pre-fractionation before injection.
Column contamination	<ul style="list-style-type: none"> • Flush column with strong solvent after each run • Improve sample cleanup
Solvent impurities	<ul style="list-style-type: none"> • Use HPLC-grade solvents

Problem: Negative peaks

Possible cause	Solution
Refractive index detection – refractive index of solute less than that of mobile phase	<ul style="list-style-type: none"> • Reverse polarity to make peak positive
UV-absorbance detection – absorbance of solute less than that of mobile phase	<ul style="list-style-type: none"> • Use mobile phase with lower UV absorbance • If recycling solvent, stop recycling when recycled solvent affects detection

Problem: Peak doubling

If all peaks have shoulders or elute as double peaks, the cause may originate from clogged inline filters, column inlet frits, contaminated pre-columns or a void volume at the column head. In most cases, the column may be returned to its original state by cleaning or replacement of the inlet frit. A short-term solution to this problem may also be to invert the column. Destroyed bed at the column outlet contributes only marginally to peak spreading.

Possible cause	Solution
Blocked frit	<ul style="list-style-type: none"> • Replace or clean frit • Install 0.5-μm porosity in-line filter between pump and injector to eliminate mobile-phase contaminants or between injector and column to eliminate sample contaminants
Co-elution of interfering compound	<ul style="list-style-type: none"> • Use sample cleanup or pre-fractionation • Adjust selectivity by changing mobile or stationary phase
Co-elution of interfering compound from previous injection	<ul style="list-style-type: none"> • Flush column with strong solvent at end of run • End gradient at higher solvent concentration
Column overloaded	<ul style="list-style-type: none"> • Use higher-capacity stationary phase • Increase column diameter • Decrease sample amount
Column void or channelling	<ul style="list-style-type: none"> • Replace column
Injection solvent too strong	<ul style="list-style-type: none"> • Use weaker injection solvent or stronger mobile phase
Sample volume too large	<ul style="list-style-type: none"> • Use injection volume equal to 1% of the total column tube volume when sample is diluted in mobile phase • Reduce sample volume • Dilute sample • Inject sample prepared in mobile phase
Sample dissolved in strong solvent	<ul style="list-style-type: none"> • Dissolve sample in mobile phase or (if not possible) inject very small sample volume

Problem: Peak fronting

Possible cause	Solution
Channelling in column	<ul style="list-style-type: none"> • Replace or repack column
Column overloaded	<ul style="list-style-type: none"> • Use higher-capacity stationary phase • Increase column diameter • Decrease sample amount • Dilute sample
Pre-column defective or soiled	<ul style="list-style-type: none"> • Change pre-column
Sample dissolved in wrong solvent	<ul style="list-style-type: none"> • Dissolve sample in mobile phase or (if not possible) inject smaller sample volume
Interfering compounds in the sample	<ul style="list-style-type: none"> • Test column using a test- or calibrations sample • Sample clean-up advised
Sample precipitation	<ul style="list-style-type: none"> • Use simple test-tube experiment to determine solubility of sample in mobile phase to prevent on-column precipitation

Problem: Peak tailing

The tailing of peaks that are eluted early is caused by extra column effects. To remedy, the entire system should be checked – capillary connections, tubings and the detector cell. Secondary, non-specific interaction with the silica gel surface leads to a tailing of late eluting peaks and even to the appearance of double peaks. Addition of triethylamine or acetate to the mobile phase or selecting a suitable stationary phase will considerably improve the peak form. An inappropriately selected pH-value for the mobile phase may also lead to peak tailing. In principle, chromatography should be carried out one pH unit above or below the pK values of the sample substances.

Possible cause	Solution
Basic solutes – silanol interactions	<ul style="list-style-type: none"> • Use competing base such as triethylamine • Use a stronger mobile phase • Increase buffer or salt concentration (ion-pair-chromatography) • Use base-deactivated silica-based reversed-phase column • Use polymeric column • Use lower mobile phase pH
Chelating solutes – trace metals in base silica	<ul style="list-style-type: none"> • Use high purity silica-based column with low trace-metal content • Add EDTA or chelating compound to mobile phase • Use polymeric column
Silica-based column – degradation at high pH	<ul style="list-style-type: none"> • Use polymeric, sterically protected, or high-coverage reversed-phase column • Install silica gel saturator column between pump and injector
Silica-based column – degradation at high temperature	<ul style="list-style-type: none"> • Reduce temperature to less than 50°C
Silica-based column – silanol interactions	<ul style="list-style-type: none"> • Decrease mobile-phase pH to suppress silanol ionization • Increase buffer concentration • Derivatize solute to change polar interactions
Void formation at head of column	<ul style="list-style-type: none"> • Replace column • To prevent: Rotate injection valve quickly • Use injection valve with pressure bypass • Avoid pressure shock
Column overload	<ul style="list-style-type: none"> • Decrease sample size • Increase column diameter • Use higher capacity stationary phase
Blocked column frit	<ul style="list-style-type: none"> • Replace frit • Add in-line filter • Filter samples
Interfering compounds in the sample / Impurities	<ul style="list-style-type: none"> • Improve sample cleanup • Test column with test sample or calibrations sample • Use HPLC-grade solvents
Adsorption of the sample onto the column (especially basic compounds)	<ul style="list-style-type: none"> • Use a different stationary phase (special phase for basic compounds) • Use buffered mobile phase

Problem: Spikes

Possible cause	Solution
Bubbles in mobile phase	<ul style="list-style-type: none"> • Degas mobile phase • Use back-pressure restrictor at detector outlet • Ensure that all fittings are tight
Column stored without caps	<ul style="list-style-type: none"> • Store column tightly capped • Flush reversed-phase columns with degassed methanol

Problem: No peaks

Possible cause	Solution
No flow through detector; Leak	<ul style="list-style-type: none"> • Check pump • Check connections and fittings in the system and column end-fittings and tighten • Check frit • Check mobile phase composition • Fix leak
Sample injection is not reproducible	<ul style="list-style-type: none"> • Check sample injection system
No sample injected	<ul style="list-style-type: none"> • Make sure the injector is working properly and sample is not precipitated.
No detectability	<ul style="list-style-type: none"> • Make sure analytes are monitored under proper conditions

Problem: Peaks with shoulders, split peaks

Possible cause	Solution
Guard column defect or dirty	<ul style="list-style-type: none"> • Exchange guard column
Column head dirty	<ul style="list-style-type: none"> • Exchange inlet frit or filter
Dead space of column head or channels in column	<ul style="list-style-type: none"> • Use new analytical column
Sample dissolved in solvent which is not compatible with eluent.	<ul style="list-style-type: none"> • Dissolve sample in eluent • Decrease injection volume

Recovery

Problem: Poor sample recovery

Possible cause	Solution
Absorption or adsorption of proteins	<ul style="list-style-type: none"> • Change HPLC mode to reduce non-specific interactions • Add protein-solubilising agent, strong acid or base (with polymeric columns only), or detergent such as SDS to mobile phase.
Adsorption on column packing	<ul style="list-style-type: none"> • Increase mobile phase strength to minimize adsorption • For basic compounds add competing base or use base-deactivated packing
Adsorption on tubing and other hardware components	<ul style="list-style-type: none"> • Use inert (PEEK), glass-lined, or titanium tubing and flow-path components
Chemisorptions on column packing	<ul style="list-style-type: none"> • Ensure no reactive groups are present • Use polymeric packing • Change column type and mode
Hydrophobic interactions between stationary	<ul style="list-style-type: none"> • Use short-chain reversed-phase packing • Use 300-Å pore diameter packing • Use hydrophilic packing or ion-exchange media • Use hydrophobic interaction chromatography
Less than 99% yield for basic compounds irreversible adsorption on active sites	<ul style="list-style-type: none"> • Use endcapped, base-deactivated, sterically protected, high coverage, or polymeric reversed-phase
Less than 90% yield for acidic compounds – irreversible adsorption on active sites	<ul style="list-style-type: none"> • Use endcapped or polymeric packing • Acidify mobile phase

Leaks

Problem: Leak at column or fittings

Possible cause	Solution
Loose fitting	<ul style="list-style-type: none"> • Check connections and fittings in the system and column end-fittings and tighten or replace fitting
Precipitation (white powder) at loose fitting	<ul style="list-style-type: none"> • Cut tubing and replace ferrule • Disassemble fitting, rinse and reassemble

Problem: Leak at detector

Possible cause	Solution
Detector-seal failure	<ul style="list-style-type: none"> • Replace detector seal or gaskets

Problem: Leak at injection valve

Possible cause	Solution
Worn or scratched valve rotor	<ul style="list-style-type: none"> • Replace valve rotor

Problem: Leak at pump

Possible cause	Solution
Pump-seal failure	<ul style="list-style-type: none"> • Replace pump seal • Check piston for scratches and, if necessary, replace.

Selectivity

Problem: Differences in selectivity

Possible cause	Solution
Differences in mobile phase composition	<ul style="list-style-type: none"> • Check pump • Check frit • Avoid evaporation or degradation of mobile phase
New eluent composition is slightly different (i.e. pH is not adjusted, solvent contains contaminants)	<ul style="list-style-type: none"> • Make up new eluent • Accurately determine volume, salt addition and pH value
Too weak solvent/eluent not buffered	<ul style="list-style-type: none"> • Use buffer or ion-pair system
Sample dissolved in different solvents	<ul style="list-style-type: none"> • Dissolve sample in mobile phase or (if not possible) inject very small sample volume
Decreasing column life; Contamination	<ul style="list-style-type: none"> • Replace column • Improve sample cleanup • Check column with test mixture • Use HPLC-grade solvents
Temperature variations in the buffer	<ul style="list-style-type: none"> • Use column thermostat
Column to column reproducibility	<ul style="list-style-type: none"> • Replace column • Check with manufacturer
Column irreversibly changed	<ul style="list-style-type: none"> • Use new column

Baseline

Problem: Disturbance at void time

Possible cause	Solution
Air bubbles in mobile phase	<ul style="list-style-type: none"> • Degas or use back-pressure restrictor on detector
Positive-negative – difference in refractive index of injection solvent and mobile phase	<ul style="list-style-type: none"> • Normal with many samples • Use mobile phase as sample solvent

Problem: Drifting baseline

Possible cause	Solution
Negative direction (gradient elution) – absorbance of mobile-phase A	<ul style="list-style-type: none"> • Use non-UV absorbing mobile phase solvents • Use HPLC grade mobile phase solvents
Positive direction (gradient elution) – absorbance of mobile phase B	<ul style="list-style-type: none"> • Use higher UV absorbance detector wavelength • Use non-UV absorbing mobile phase solvents • Use HPLC grade mobile phase solvents
Positive direction – contamination build-up and elution	<ul style="list-style-type: none"> • Flush column with strong solvent • Clean up sample • Use HPLC grade solvents
Wavy or undulating – temperature changes in room	<ul style="list-style-type: none"> • Monitor and control changes in room temperature • Insulate column or use column oven • Cover refractive index detector and keep it out of air currents.

Problem: Noise

Possible cause	Solution
Continuous – detector lamp problem or dirty flow cell	<ul style="list-style-type: none"> • Replace UV lamp (each should last 2000 h) • Clean and flush flow cell
Gradient or isocratic proportioning – lack of solvent mixing	<ul style="list-style-type: none"> • Use proper mixing device • Check proportioning precision by spiking one solvent with UV absorbing compound and monitor UV absorbance detector output
Gradient or isocratic proportioning – malfunctioning proportioning valves	<ul style="list-style-type: none"> • Clean or replace proportioning precision valves • Partially remix solvents
Occasional sharp spikes – external electrical interference	<ul style="list-style-type: none"> • Use voltage stabilizer for LC system • Use independent electrical circuit
Periodic – pump pulses	<ul style="list-style-type: none"> • Service or replace pulse damper • Purge air from pump • Change piston seals • Clean or replace check valves.
Random – contamination build-up	<ul style="list-style-type: none"> • Flush column with strong solvent • Clean up sample • Use HPLC grade solvent
Spikes – bubble in detector	<ul style="list-style-type: none"> • Degas mobile phase • Use back-pressure restrictor at detector outlet
Spikes – column temperature higher than boiling point of solvent	<ul style="list-style-type: none"> • Use lower column temperature

Pressure

Problem with pressure is usually connected with too high back-pressure, and to elucidate where the problem is originating, a good laboratory practice is to disconnect the system stepwise starting at the pump and working towards the detector.

Problem: Decreasing pressure

Possible cause	Solution
Insufficient flow to pump	<ul style="list-style-type: none">• Loosen cap on mobile phase reservoir
Leak in hydraulic lines from pump to column	<ul style="list-style-type: none">• Tighten or replace fittings• Tighten rotor in injection valve
Leaking pump check valve or seals	<ul style="list-style-type: none">• Replace or clean check valves• Replace pump seals.
Pump cavitations	<ul style="list-style-type: none">• Degas solvent• Check for obstruction in line from solvent reservoir to pump• Replace inlet-line frit

Problem: Fluctuating pressure

Possible cause	Solution
Bubble in pump	<ul style="list-style-type: none">• Degas solvent• Purge solvent with helium
Leaking pump check valve or seals	<ul style="list-style-type: none">• Replace or clean check valves• Replace pump seals

Problem: High back-pressure

Possible cause	Solution
Pre/guard column blocked	<ul style="list-style-type: none"> • Exchange pre/guard column • Exchange column inlet frit • Back-flush column • Exchange column
Column head blocked	<ul style="list-style-type: none"> • Change filter of column head • Flush column • Change column
Capillary blocked	<ul style="list-style-type: none"> • Exchange capillary
Column blocked with irreversibly adsorbed sample	<ul style="list-style-type: none"> • Improve sample cleanup • Use guard column • Reverse-flush column with strong solvent to dissolve blockage
Column particle size too small (for example 3 micrometers)	<ul style="list-style-type: none"> • Use larger particle size (for example 5 micrometer)
Microbial growth on column	<ul style="list-style-type: none"> • Use at least 10% organic modifier in mobile phase • Use fresh buffer daily • Add 0.02% sodium azide to aqueous mobile phase • Store column in at least 25% organic solvent without buffer
Mobile phase viscosity too high	<ul style="list-style-type: none"> • Use lower viscosity solvents or higher temperature
Plugged frit in in-line filter or guard column	<ul style="list-style-type: none"> • Replace frit or guard column
Plugged inlet frit	<ul style="list-style-type: none"> • Replace end-fitting or frit assembly
Polymeric columns – solvent change causes swelling of packing	<ul style="list-style-type: none"> • Use correct solvent with column • Change to proper solvent composition • Consult manufacturer's solvent-compatibility chart • Use a column with a higher percentage of cross-linking
Salt precipitation (especially in reversed-phase chromatography with high concentration of organic solvent in mobile phase)	<ul style="list-style-type: none"> • Ensure mobile phase compatibility with buffer concentration • Decrease ionic strength and water-organic solvent ratio • Premix mobile phase
When injector disconnected from column – blockage in injector	<ul style="list-style-type: none"> • Clean injector or replace rotor

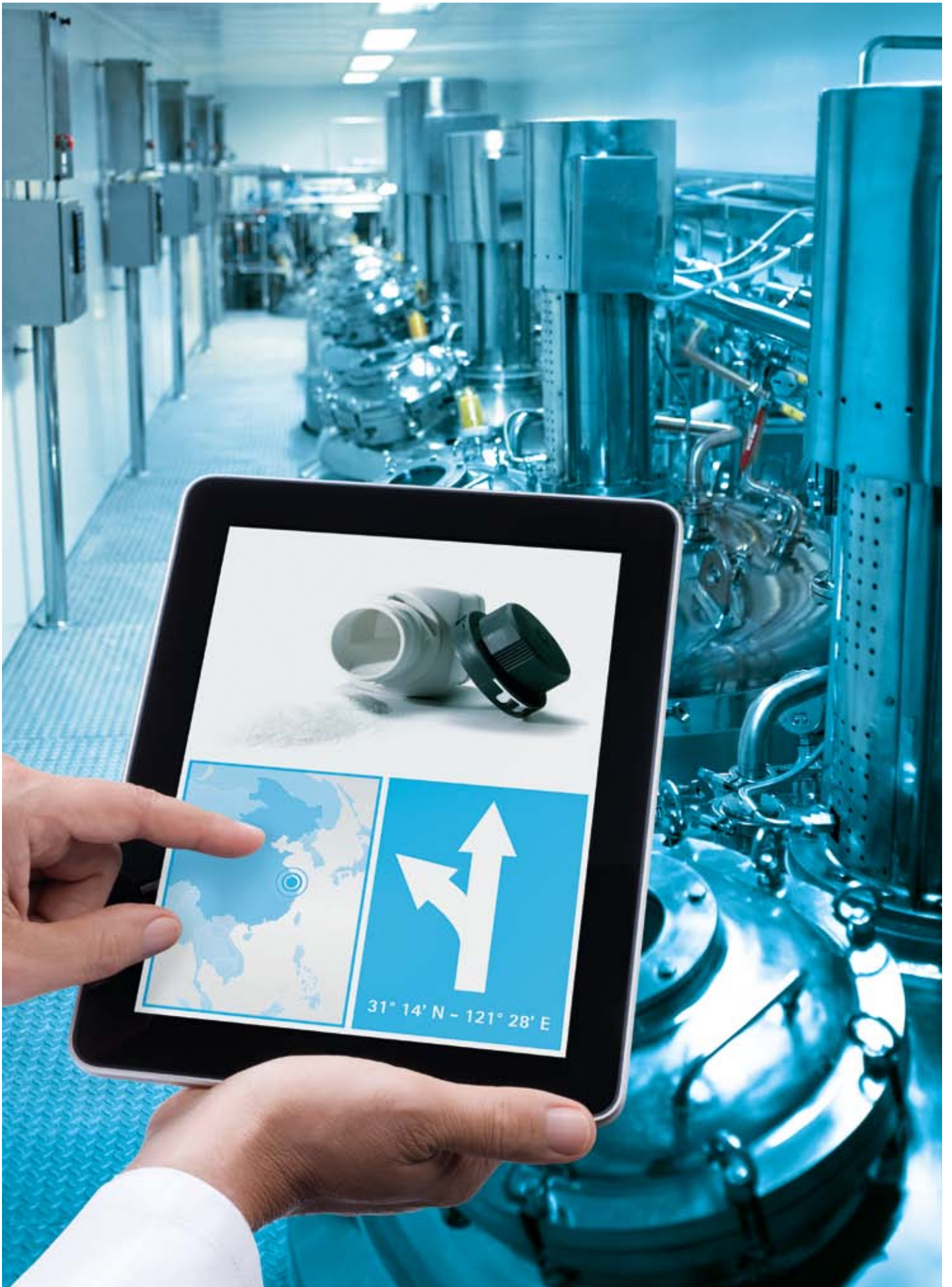

Preparative HPLC

Our voyage takes us inside the production facilities of a reputable pharmaceutical company. Special procedures are required to enter since nothing should deter from the quality of their products. Another way they secure purity is with preparative chromatography technology from Merck Millipore. As a specialist in this field, our job is to ensure a safe, fast and direct transfer to production scale of pharmaceutical and chemical products. We provide standardized silica gel packaging materials, as well as high performance sorbents, which are all based on consistent high-quality raw materials. So no matter which chromatography process you choose, the results are always the same: safe and sound.

Preparative HPLC	page 333
Aluminium oxide For preparative chromatography	page 334
Standardized silica gels	page 336
LiChroprep®	page 338
LiChrospher®	page 341
Other sorbents For preparative chromatography	page 342
Micro-crystalline cellulose	page 343
Florisil®	page 344
Chromolith® Prep Chromolith® – increase in speed, efficiency and productivity	page 345
Hibar® pre-packed columns	page 346
Hibar® customized pre-packed columns 25 and 50 mm internal diameter	page 347
Scaling the separation	page 348

Preparative high performance liquid chromatography

Sorbents and columns

Preparative column chromatography plays an important role in purifying valuable compounds in research, pilot plant operation and production. The advantage of this method is that it delivers high levels of purity in a rapid and economical manner.

Merck Millipore is a specialist in the manufacture of standardized silica gel packing materials for preparative chromatography. We provide a wide range of products for the purification of APIs and intermediates designed to meet the special requirements of our customer's process: Silica Gel 60 is the right choice if you are looking for a reliable silica gel for simple adsorption processes and normal-phase chromatography. If you need a silica gel for advanced normal-phase and reverse-phase chromatography, we recommend using the irregular shaped LiChroprep® or the perfect spherical LiChrospher® – highly versatile materials providing fast, effective and reproducible separation. Our comprehensive product portfolio is completed by our high-quality Hibar® columns – delivered standardized, pre-packed and ready-to-use.

With regulatory demands growing steadily in the field of chromatography sorbents, it makes sense to work with a supplier who values control and quality as highly as you do – and who can provide the regulatory support you need for peace of mind. Merck Millipore is the biggest dedicated producer of chromatography-grade silica gels in the world – a huge number of process chromatographers use Merck Millipore silica gels in their daily work. They know that with the consistent high-quality of Merck Millipore sorbents, they can trust their results – today and tomorrow.



Aluminium oxide

For preparative chromatography

M. S. Tswett used aluminium oxide as a sorbent when he discovered chromatography in the year 1903. One year after his invention, Merck Millipore started to offer aluminium oxide for adsorption chromatography.

The aluminium oxide crystal structure comprises octahedrally and tetrahedrally coordinated aluminium coupled by oxygen atoms. The aluminium oxide surface is covered by free hydroxyl groups. There are different acidic and basic centers (Bronsted acid, Lewis acid and Lewis basic centers) that result in anion and cation exchange properties. Aluminium oxide exhibits a higher pH-stability than silica gel, especially in the alkaline range. Aluminium oxide occurs in various crystal modifications resulting in different pore diameters. Our offering comprises aluminium oxides with pore diameters of 6 nm, 9 nm and 15 nm.

Standardized aluminium oxide 90, for adsorption analysis according to Brockmann, is a sorbent of medium polarity. It is frequently used when the cation exchange properties of basic alumina are required. Furthermore, aluminium oxide may be used as an alternative to activated carbon, when the organic character of activated carbon can be problematic.

Typical technical data of aluminium oxide packing materials

Packing material	Characteristics	Spec. surface area S_{BET} [m ² /g]	Pore volume V_p [mL/g]	Particle size d_p [μm]	pH	Brockmann-Activity
Aluminium oxide 60	irregular particles of alumina mean pore size: 6 nm (60 Å)	~160	0.3	63-200	9	I
Aluminium oxide 90	irregular particles of alumina mean pore size: 9 nm (90 Å)	90-120	0.3	63-200	4, 7, 9	I, II-III
Aluminium oxide 150	irregular particles of alumina mean pore size: 15 nm (150 Å)	60-90	0.3	63-200	9	I-II

Chromatographic results strongly depend on the water content of the sorbent. Water adsorbed on the sorbent surface reduces the activity, i.e. the adsorption strength of the adsorption sites. In the 1940's Brockmann and Schodder developed a method to determine a sorbent's activity by using various different dyes (Chem. Ber., 74B, 73 (1941)). They correlated sorbent activity to the retention factor (Rf) of these dyes. The table below shows the typical amounts of water that need to be added to a sorbent of activity I to reach the required Brockmann activity number.

Typical amounts of water to be added to a sorbent of activity I to reach the required Brockmann activity number

Water added [%]	Activity grade [Brockmann]	Retention factor [Rf] of dye
0	I	0.15
3	II	0.22
6	III	0.33
10	IV	0.44
15	V	0.65

Ordering information – Aluminium oxide packing materials

Product	Ordering No.	Activity	pH*	Contents
Aluminium oxide 60, active, basic	1.01067.1000	I	9	1 kg
Aluminium oxide 60, active, basic	1.01067.2000	I	9	2 kg
Aluminium oxide 90, active, basic	1.01076.1000	I	9	1 kg
Aluminium oxide 90, active, basic	1.01076.2000	I	9	2 kg
Aluminium oxide 90, active, basic	1.01076.9020	I	9	20 kg
Aluminium oxide 90, active, neutral	1.01077.1000	I	7	1 kg
Aluminium oxide 90, active, neutral	1.01077.2000	I	7	2 kg
Aluminium oxide 90, active, neutral	1.01077.9020	I	7	20 kg
Aluminium oxide 90, active, acidic	1.01078.1000	I	4	1 kg
Aluminium oxide 90, active, acidic	1.01078.2000	I	4	2 kg
Aluminium oxide 90, active, acidic	1.01078.9020	I	4	20 kg
Aluminium oxide 90, standardized acc. to Brockmann	1.01097.1000	II-III	9	1 kg
Aluminium oxide 90, standardized acc. to Brockmann	1.01097.5000	II-III	9	5 kg
Aluminium oxide 90, standardized acc. to Brockmann	1.01097.9050	II-III	9	50 kg
Aluminium oxide 150, basic	1.01061.1000	I-II	9	1 kg
Aluminium oxide 150, basic	1.01061.2000	I-II	9	2 kg

*pH of 10% aqueous suspension

Standardized silica gels

Standardized silica gels from Merck Millipore are produced using a traditional method in the world's largest and most modern production plant for chromatography grade silica gels. Standardized silica gels are widely used in separation processes to purify high value compounds in ton quantities.

Standardized silica gels are available in many particle size ranges all derived from a single base silica gel, specifically produced only for adsorption and chromatography processes. Standardized silica gels offer easy development of your process from thin layer chromatography to any scale. Standardized silica gels are available in a wide variety of pack sizes from 500 g to 400 kg to suit your specific needs. Typically, bottles and drums out of pure HDPE are used that are approved for pharmaceutical and food applications.



► Lab Water Purification
Production of ultrapure
water suitable for HPLC
page 31

Typical technical data of standardized silica gel packing materials

Packing material	Characteristics	Spec. surface area S_{BET} [m ² /g]	Pore volume V_p [mL/g]	pH*	Water content [%]
Silica gel 40	irregular particles of silica; mean pore size: 4 nm (40 Å)	600	0.6	7.0	< 7
Silica gel 60	irregular particles of silica; mean pore size: 6 nm (60 Å)	500	0.8	7.0	< 7
Silica gel 100	irregular particles of silica; mean pore size: 10 nm (100 Å)	360	0.8	7.0	< 7

*pH of 10% aqueous suspension

Ordering information – Silica gel packing materials

Product	Ordering No.	Particle size	Particle size distribution	Contents
Silica gel 40	1.10180.1000	63-200 µm	70-230 mesh ASTM	1 kg
Silica gel 40	1.10180.5000	63-200 µm	70-230 mesh ASTM	5 kg
Silica gel 40	1.10180.9025	63-200 µm	70-230 mesh ASTM	25 kg
Silica gel 40	1.10181.1000	200-500 µm	35-70 mesh ASTM	1 kg
Silica gel 40	1.10181.9025	200-500 µm	35-70 mesh ASTM	25 kg
Silica gel 60	1.15111.1000	15-40 µm	–	1 kg
Silica gel 60	1.15111.2500	15-40 µm	–	2.5 kg
Silica gel 60	1.15111.9025	15-40 µm	–	25 kg
Silica gel 60	1.09389.5000	35-70 µm	200-400 mesh ASTM	5 kg
Silica gel 60	1.09389.9025	35-70 µm	200-400 mesh ASTM	25 kg
Silica gel 60	1.09385.1000	40-63 µm	230-400 mesh ASTM	1 kg
Silica gel 60	1.09385.2500	40-63 µm	230-400 mesh ASTM	2.5 kg
Silica gel 60	1.09385.5000	40-63 µm	230-400 mesh ASTM	5 kg
Silica gel 60	1.09385.9025	40-63 µm	230-400 mesh ASTM	25 kg
Silica gel 60	1.07729.1000	< 63 µm	> 230 mesh ASTM	1 kg
Silica gel 60	1.07729.5000	< 63 µm	> 230 mesh ASTM	5 kg
Silica gel 60	1.07729.9025	< 63 µm	> 230 mesh ASTM	25 kg
Silica gel 60	1.15101.1000	63-100 µm	170-230 mesh ASTM	1 kg
Silica gel 60	1.15101.9025	63-100 µm	170-230 mesh ASTM	25 kg
Silica gel 60	1.07734.1000	63-200 µm	70-230 mesh ASTM	1 kg

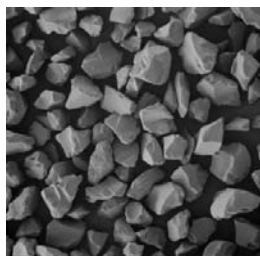

LiChroprep® is a proven, highly successful packing material providing fast, effective and reproducible separations. LiChroprep® is one of the most successful and reliable sorbents used in HPLC and medium pressure chromatography. It has a well documented history in the technical literature with several hundred applications described.

LiChroprep® is an irregular shaped silica gel packing material characterized by:

- A reproducible homogeneous silica gel matrix
- A narrow, well defined particle size distribution for high performance and high permeability
- Excellent selectivity and efficiency
- A large number of applications
- Large batch size
- Comprehensive regulatory documents are available

The totally porous irregular particles are tightly classified in the 15–25 µm, 25–40 µm and 40–63 µm ranges. LiChroprep® is available in ready-to-use Hibar® 250–25 mm columns as well as in different bulk pack sizes.

Typical technical data of LiChroprep® packing materials

Packing material	Characteristics	Spec. surface area S_{BET} [m ² /g]	Pore volume V_p [mL/g]	Particle size d_p [µm]	% C	Surface coverage [µmol/m ²]
LiChroprep® Si 60	irregular particles of silica; mean pore size: 6 nm (60 Å)	500	0.8	15-25 25-40 40-63	–	–
LiChroprep® NH ₂	irregular particles of silica with aminopropyl function	300	1.0	15-25 25-40 40-63	3.5	3.0
LiChroprep® DIOL	irregular particles of silica with vicinal hydroxyl function on C-chains; for special normal phase chromatography	300	1.0	15-25 25-40 40-63	7	3.9
LiChroprep® RP-18	irregular particles of silica with octadecyl derivative	300	1.0	15-25 25-40 40-63	16	3.0
LiChroprep® RP-8	irregular particles of silica with octyl derivative	500	1.0	15-25 25-40 40-63	13	3.4
LiChroprep® CN	Irregular particles of silica with cyanopropyl function on C-chains; for normal and reverse phase chromatography	300	1.0	15-25 25-40 40-63	6	3.8

Ordering information of LiChroprep® packing materials

Packing material	Ordering No.	Particle size	Quantity
LiChroprep® Si 60	1.09336.1000	15-25 µm	1 kg
LiChroprep® Si 60	1.09336.9025	15-25 µm	25 kg
LiChroprep® Si 60	1.09390.1000	25-40 µm	1 kg
LiChroprep® Si 60	1.13905.0250	40-63 µm	250 g
LiChroprep® Si 60	1.13905.1000	40-63 µm	1 kg
LiChroprep® Si 60	1.13905.9025	40-63 µm	25 kg
LiChroprep® RP-18	1.13901.0500	15-25 µm	500 g
LiChroprep® RP-18	1.13901.9010	15-25 µm	10 kg
LiChroprep® RP-18	1.09303.0100	25-40 µm	100 g
LiChroprep® RP-18	1.09303.0500	25-40 µm	500 g
LiChroprep® RP-18	1.09303.5000	25-40 µm	5 kg
LiChroprep® RP-18	1.09303.9025	25-40 µm	25 kg
LiChroprep® RP-18	1.13900.0250	40-63 µm	250 g
LiChroprep® RP-18	1.13900.1000	40-63 µm	1 kg
LiChroprep® RP-18	1.13900.9025	40-63 µm	25 kg
LiChroprep® DIOL	1.13973.0250	40-63 µm	250 g
LiChroprep® NH ₂	1.13974.0250	40-63 µm	250 g
LiChroprep® NH ₂	1.13974.1000	40-63 µm	1 kg
LiChroprep® CN	1.13959.0250	40-63 µm	250 g
LiChroprep® RP-8	1.09362.0250	40-63 µm	250 g
LiChroprep® RP-8	1.09362.1000	40-63 µm	1 kg

Chemical structure of Prostaglandin

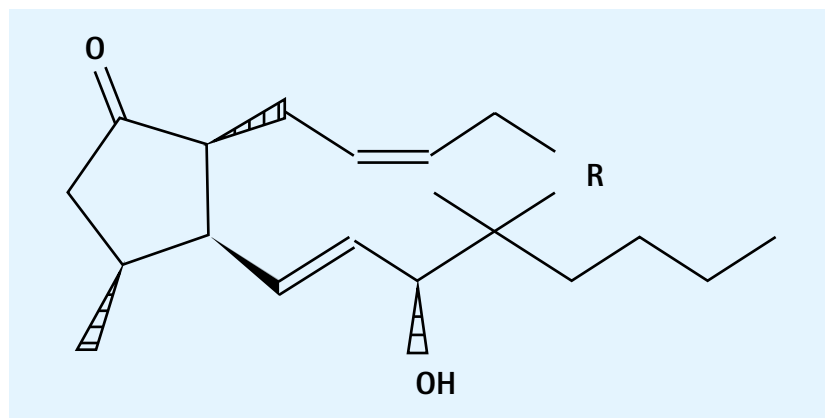

Please have a look at page 358 for further information about LiChroprep® application for Prostaglandins.

Upscale of an analytical HPLC method to a preparative separating system

Analytical HPLC method with LiChrosorb® Si 60,
250–4 mm

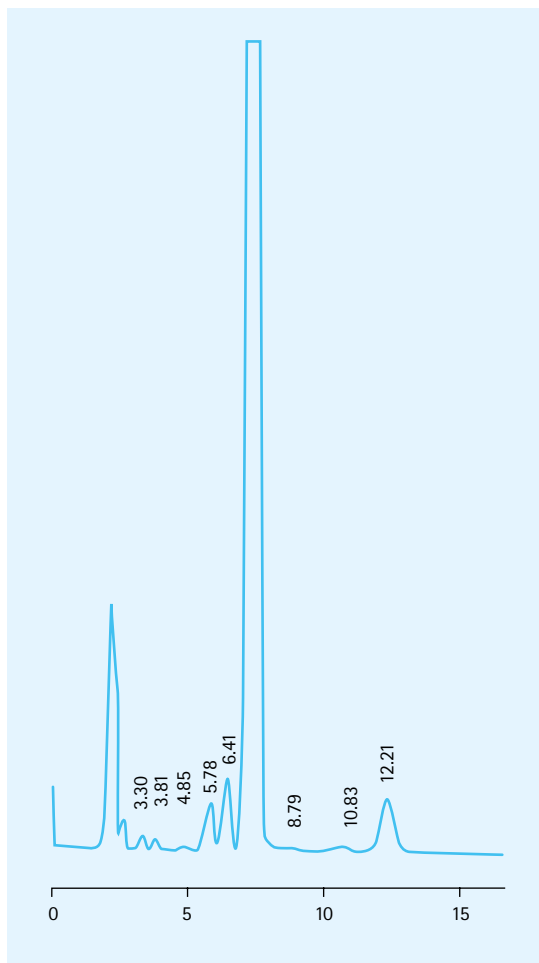

Column	LiChrosorb® Si 60, 250–4 mm	
Mobile phase	n-Heptan	96
	IPA	2.4
	MeOH	1.0
	THF	0.6 (V/V)
Particle size	10 µm	
Flow rate	1.5 mL/min	
Detection	UV 204 nm	
Sample	Prostaglandin	

Preparative separating system with LiChrosorb® Si 60,
600–200 mm

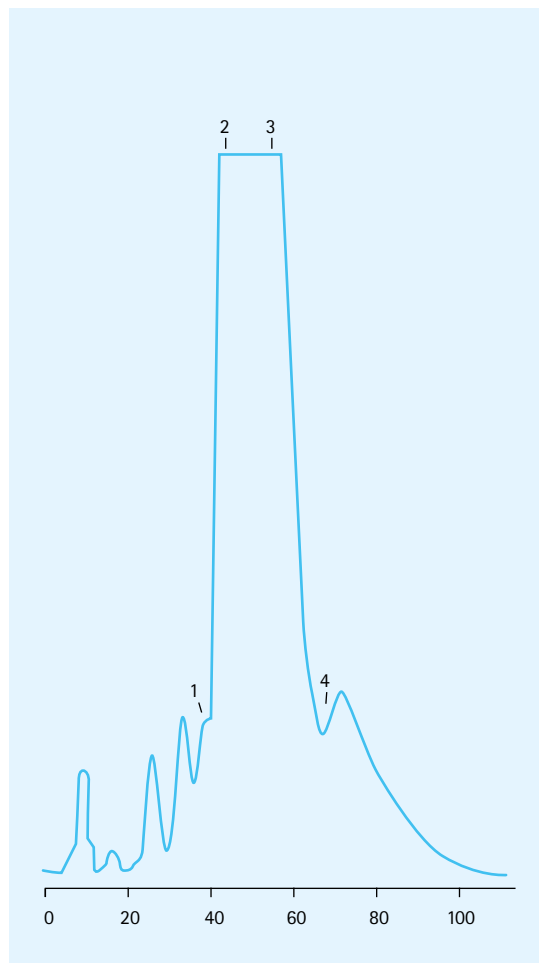

Column	LiChrosorb® Si 60, 600–200 mm	
Mobile phase	n-Heptan	96
	IPA	2.4
	MeOH	1.0
	THF	0.6 (V/V)
Particle size	25–40 µm	
Flow rate	2.0 L/min	
	200 g Feed in 5 L Eluent	
Sample	Prostaglandin	

LiChrospher®

LiChrospher® for preparative high performance liquid chromatography is a spherical silica gel that is traditionally produced by using water glass as raw material. LiChrospher® is available in 12 µm particles with different chemistries to ensure a rapid and simple optimisation of the chromatographic system. LiChrospher® is available in ready-to-use Hibar® columns of various lengths as well as in different bulk pack sizes.

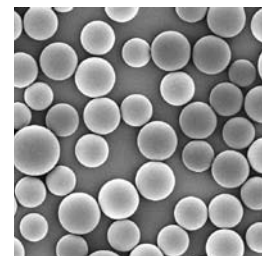

Typical technical data of LiChrospher® packing materials

Packing material	Characteristics	Spec. surface area S_{BET} [m ² /g]	Pore volume V_p [mL/g]	Particle size d_p [µm]	% C	Surface coverage [µmol/m ²]
LiChrospher® Si 60	spherical particles of silica medium pore size: 6 nm (60 Å)	700	0.9	12	–	–
LiChrospher® 100 RP-18	spherical particles of silica with octadecyl derivative	350	1.2	12	21.0	3.6
LiChrospher® 100 RP-18 endcapped	spherical particles of silica with octadecyl derivative endcapped	350	1.2	12	21.0	3.6

Ordering information – LiChrospher®

Product	Ordering No.	Particle size	Quantity
LiChrospher® Si 60	1.19654.0100	12 µm	100 g
LiChrospher® Si 60	1.19654.1000	12 µm	1 kg
LiChrospher® 100 RP-18	1.19656.0100	12 µm	100 g
LiChrospher® 100 RP-18	1.19656.0500	12 µm	500 g
LiChrospher® 100 RP-18e	1.19676.0100	12 µm	100 g

- ▶ **Lab Water Purification**
Production of ultrapure water suitable for HPLC
page 31
- ▶ **Purospher® STAR RP-18 endcapped**
The versatility you need!
page 219
- ▶ **Purospher® STAR RP-8 endcapped** Optimized for more polar compounds
page 236
- ▶ **Purospher® STAR Si (Silica) and NH₂ (Amino-phase)**
page 238
- ▶ **Superspher®**
Silica carrier for highly efficient separations
page 246
- ▶ **LiChrospher®**
Silica carrier for constant top-rate results
page 250
- ▶ **LiChrosorb®**
Irregular shaped silica sorbent
page 272

Other sorbents

For preparative chromatography

Silanized Silica 60 is an alternative material for the economic purification of products, where conventional RP-phases are too expensive. Derivatized silica gels show high loading capacities due to the high specific surface area of the basic silica 60.

Typical technical data of Silica gel 60 silanized

Packing material	Characteristics	Spec. surface area S_{BET} [m^2/g]	Pore volume V_p [mL/g]	Particle size d_p [μm]
Silica 60 silanized	irregular particles of silica; mean pore size: 6 nm (60 Å)	500	0.8	63-200

Ordering information – Silica 60 silanized

Product	Ordering No.	Particle size	Particle size distribution	Quantity
Silica gel 60 silanized (dimethylsilane derivate)	1.07719.0250	63-200 μm	70-230 mesh ASTM	250 g
Silica gel 60 silanized (dimethylsilane derivate)	1.07719.1000	63-200 μm	70-230 mesh ASTM	1 kg

Ordering information – Florisil®

Product	Ordering No.	Particle size	Particle size distribution	Quantity
Florisil®	1.12518.0100	150-250 μm	60-100 mesh ASTM	100 g
Florisil®	1.12518.1000	150-250 μm	60-100 mesh ASTM	1 kg
Florisil® for residual analysis	1.12994.0100	150-250 μm	60-100 mesh ASTM	100 g
Florisil® for residual analysis	1.12994.1000	150-250 μm	60-250 mesh ASTM	1 kg

► Lab Water Purification
Production of ultrapure
water suitable for HPLC
page 31

Micro-crystalline cellulose

Micro-crystalline cellulose is a hydrophilic polysaccharide packing material preferred for the raw separation of amino acids and related compounds. Cellulose is also used for the gentle purification of bio-molecules. Because of the organic nature of cellulose, it can only be used in pre-swollen state and under gentle or hydrostatic pressure.

Ordering information – Cellulose packing materials

Product	Ordering No.	Particle size	Quantity
Cellulose micro-crystalline Avicel®	1.02331.0500	20-160 µm	500 g
Cellulose micro-crystalline Avicel®	1.02331.2500	20-160 µm	2.5 kg
Cellulose micro-crystalline Avicel®	1.02331.9025	20-160 µm	25 kg



► Lab Water Purification
Production of ultrapure
water suitable for HPLC
page 31

Florisil® is a polar highly selective magnesium silicate of the approximate composition MgO/SiO₂ (15/85) which is particularly suitable for the separation of steroids, alkaloids, antibiotics etc. This stationary phase is also used for the sample preparation of environmental samples such as pesticide residue analysis, chlorinated hydrocarbons and pesticides.

For sample preparation in the case of pesticides, a specially purified and activated Florisil® is often used (Cat. No. 112994). The normal activation temperature for Florisil® is 650°C, while activation at 260°C produces a less active material.

Typical technical data of Florisil® packing materials

Composition	MgO 15.5% / SiO ₂ 84.0% / Na ₂ SO ₄ 0.5%
pH	8.5
S_{BET}	300 m ² /g
Specific weight	2.5 g/mL
Porosity	56%
Surface acidity (PK.)	1.5

Ordering information – Florisil®

Product	Ordering No.	Particle size	Particle size distribution	Quantity
Florisil®	1.12518.0100	150-250 µm	60-100 mesh ASTM	100 g
Florisil®	1.12518.1000	150-250 µm	60-100 mesh ASTM	1 kg
Florisil® for residual analysis	1.12994.0100	150-250 µm	60-100 mesh ASTM	100 g
Florisil® for residual analysis	1.12994.1000	150-250 µm	60-250 mesh ASTM	1 kg

Chromolith® Prep

Chromolith® – increase in speed, efficiency and productivity

Please have a look at the Chromolith® Prep pages in the analytical HPLC chapter on page 180 for more detailed information on technical data and separation examples.

Separation of α - and δ -Tocopherol from sunflower oil at different flow rates

Chromolith® Prep 100–25 mm, flow rate 40 mL/min

Column	Chromolith® Prep 100-25 mm
Solvent	n-Heptane / Dioxane (80/20 v/v)
Flow rate	40 mL/min
Sample	Sunflower oil

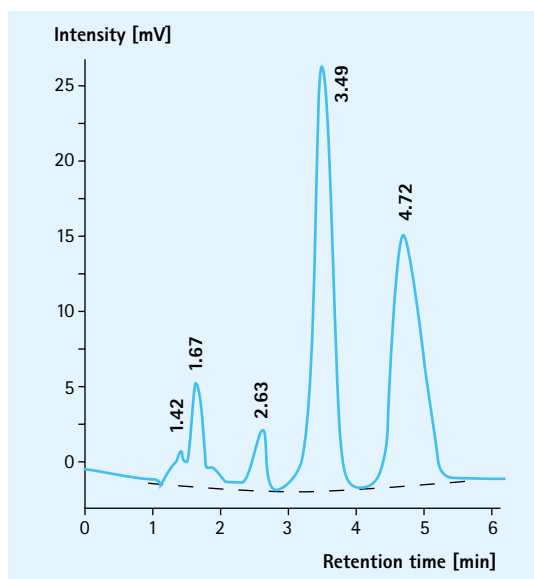

Chromolith® Prep 100–25 mm, flow rate 160 mL/min

Column	Chromolith® Prep 100-25 mm
Solvent	n-Heptane / Dioxane (80/20 v/v)
Flow rate	160 mL/min
Sample	Sunflower oil

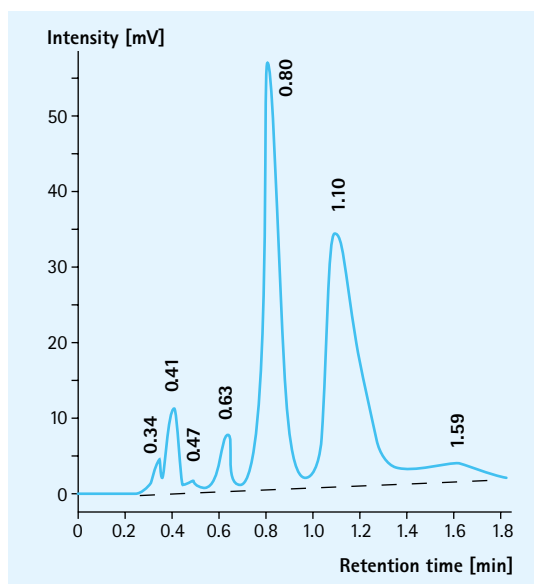

► Lab Water Purification
Production of ultrapure water suitable for HPLC
page 31

► Chromolith® RP-18
endcapped Chromolith®
RP-18 endcapped columns are the fastest C18
columns in the world.
page 172

► Chromolith® Si
page 190

Hibar® pre-packed columns

After a separation has been optimized with an analytical column, the method parameters can be easily transferred by using a pre-packed Hibar® column with an internal diameter of 25 mm or 50 mm. This size is convenient for separations of mg up to grams range of final product.

Hibar® pre-packed columns are "ready-to-use" and can easily be connected to any HPLC system, using standard 1/16" capillary male connectors at both ends. An extensive range of LiChrospher® or LiChroprep® sorbents are available. The sorbents produced by Merck Millipore are subjected to the most stringent controls; many different parameters are tested for each sorbent. These have proven their performance over many years.



Hibar® column 250-25 mm

- ▶ **Lab Water Purification**
Production of ultrapure water suitable for HPLC
page 31
- ▶ **Purospher® STAR RP-18 endcapped**
The versatility you need!
page 219
- ▶ **Purospher® STAR RP-8 endcapped** Optimized for more polar compounds
page 236
- ▶ **Purospher® STAR Si (Silica) and NH₂ (Amino-phase)**
page 238
- ▶ **Superspher®**
Silica carrier for highly efficient separations
page 246
- ▶ **LiChrospher®**
Silica carrier for constant top-rate results
page 250
- ▶ **LiChrosorb®**
Irregular shaped silica sorbent
page 272

Ordering information – Hibar® pre-packed columns, 25 mm internal diameter

Sorbent	Ordering No.	Particle size	Dimension length	Dimension i.d.	Contents of one package
LiChrospher® 100 RP-8	1.51482.0001	5 µm	250 mm	25 mm	1 column, 2 connectors 1/8"-1/16"
LiChrospher® 100 RP-18	1.51483.0001	5 µm	250 mm	25 mm	1 column, 2 connectors 1/8"-1/16"
LiChrospher® 60 RP-select B	1.51484.0001	5 µm	250 mm	25 mm	1 column, 2 connectors 1/8"-1/16"
LiChrospher® Si 60	1.51485.0001	5 µm	250 mm	25 mm	1 column, 2 connectors 1/8"-1/16"
LiChrospher® 100 RP-18e	1.51478.0001	5 µm	250 mm	25 mm	1 column, 2 connectors 1/8"-1/16"

Hibar® customized pre-packed columns

25 and 50 mm internal diameter

If you require the versatility to quickly change columns but you prefer to purchase "ready to use" columns with specific sorbents, customized packing columns provide the perfect answer.

Sorbents for universal and specific applications are available

- LiChrospher® and LiChroprep® packing materials for standard and specific applications are available
- Batch-to-batch reproducibility is our constant goal
- Columns are available with 25 and 50 mm internal diameter and in different lengths
- Short delivery times



Ordering information – HiBar® customized pre-packed columns

Sorbent	Ordering No.	Dimension length	Dimension i.d.	Contents of one package
Customized packing for RP-materials	1.50099.0001	250 mm	50 mm	1 column, connection set
Customized packing for Si, CN, Diol, NH ₂ materials	1.50092.0001	250 mm	50 mm	1 column, connection set
Customized packing	1.50004.0001	250 mm	25 mm	1 column, 2 connectors 1/8"-1/16"
Customized packing	1.50016.0001	125 mm	25 mm	1 column, 2 connectors 1/8"-1/16"
Customized packing	1.50018.0001	75 mm	25 mm	1 column, 2 connectors 1/8"-1/16"
Customized packing	1.50323.0001	30 mm	25 mm	1 column, 2 connectors 1/8"-1/16"

► Lab Water Purification
Production of ultrapure water suitable for HPLC
page 31

► HiBar® pre-packed columns
page 346

Scaling the separation

Whenever there is a need to transfer an HPLC method from one column dimension to another, from one sorbent particle size to another, or from one type of HPLC instrumentation to another (e.g. analytical to semi-preparative/preparative scale or analytical to capillary/nano-scale), many parameters need to be taken into consideration.

To be successful in scaling the separation, physical parameters such as flow rate, tubing inner diameter, detector cell volume, and injection volume (among others) need to be scaled appropriately to avoid introducing extra-column effects which prevent maintaining the integrity of the separation as it is scaled.

The VanDeemter plot for different particle sizes at different linear velocities

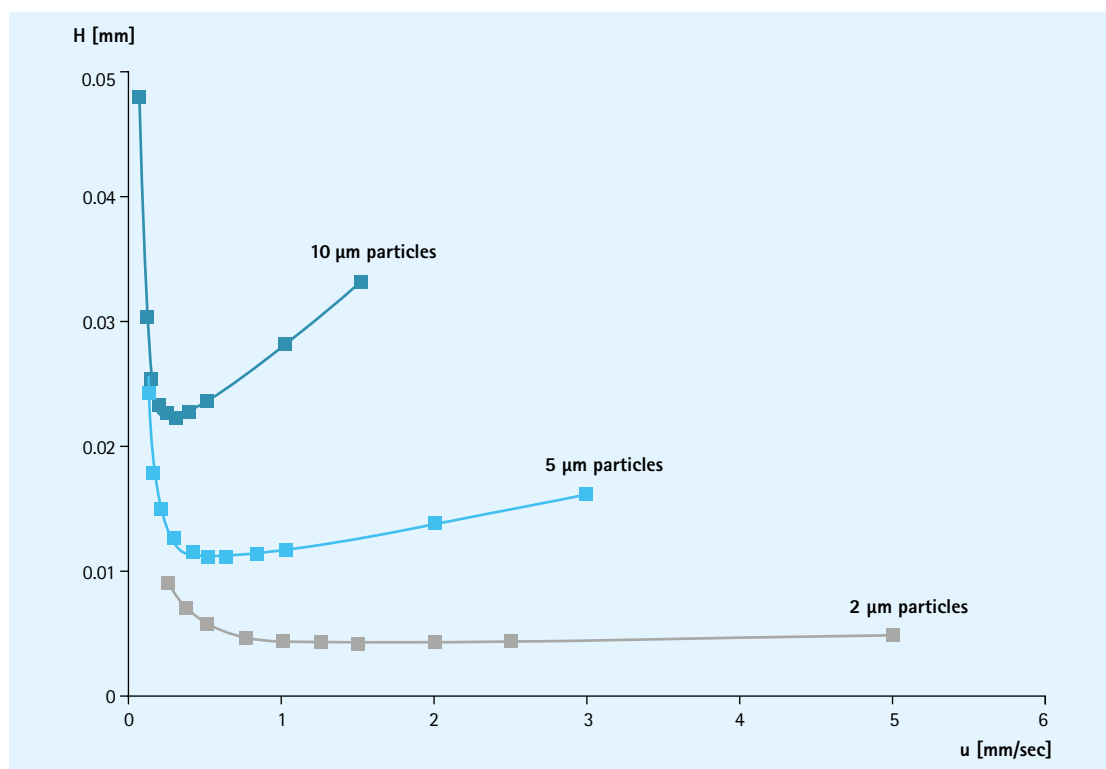

Flow rate as a function of the column inner diameter (i.d.) at the same constant linear velocity

Column i.d.	Flow rate
50 mm	120 mL/min
25 mm	30 mL/min
10 mm	5 mL/min
4.6 mm	1 mL/min
3.0 mm	0.4 mL/min
2.1 mm	0.2 mL/min
1.0 mm	0.05 mL/min

► Lab Water Purification
Production of ultrapure
water suitable for HPLC
page 31

Down-scaling

When scaling down a separation, extra-column volumes need to be carefully considered and minimized as much as possible to avoid loss of separation power (i.e. efficiency and resolution). The starting column dimensions may differ depending on the application and common practices of the laboratory.

For example, chromatographers performing quality control of pharmaceuticals often use long (150 or 250 mm) columns with 4.6 mm i.d. combined with standard UV or RI detectors. They may want to optimize the robustness and throughput of their methods by scaling down to a 3.0 or 2.1 mm i.d. column of the same or shorter length.

Other chemists may already be working with a 2.1 or 1.0 mm i.d. column method, and want to transfer it to capillary dimensions, which also requires changing the type of HPLC system used as well. In this case, many instrumentation considerations become critical as well as those required to just scale down the column dimensions on the same HPLC system. For example, factors such as optimum sample loading mass must be taken into account, as it is a function of the cross sectional area of the column.

Volume of 10 cm lengths of the most common HPLC tubing inner diameters (i.d.)

Tube i.d. [mm]	Tube [color]	Volume [inch]	Volume [μ L]
0.064	natural	0.025	0.32
0.13	red	0.05	1.3
0.17	yellow	0.07	2.3
0.25	blue	0.10	4.9
0.50	orange	0.20	20

If you consider scaling down your separation from an analytical 4.6 mm i.d. column, a good alternative is to choose 3.0 mm i.d. columns as they will provide high sensitivity and substantial solvent saving (almost 60% reduction) without the need to change the existing equipment settings. The effect from extra-column void volume is negligible in this case.

If there is a wish to save solvent, achieve higher sensitivity, and/or if the sample amount is limited, narrower i.d. columns (i.e. 2.1 or 1.0 mm i.d.) are the more proper choice. When using a 2.1 or 1.0 mm i.d. column with the same length as a 4.6mm i.d. column, the solvent savings are about 80% or 95%, respectively. The chromatographer, however, needs then to change to narrower i.d. tubing in the system, and also change from standard to semi-micro/micro flow cells when using UV detectors in order not to lose chromatographic efficiency. You don't want the detector flow cell or extra-column tubing in the system to become "mixing chambers" and undo the hard work of your method development resolution efforts as your analytes elute.

Scaling the separation | Decreased efficiency

| Injection volumes

Decreased efficiency with a large void volume

The void volume, also referred to as the dead volume, is the total volume of liquid between the injector and the detector. The size of the void volume determines the time (t_0) for a compound that is not retained on the separation material, to reach the detector.

The void volume (V_{void} or V_0) is the sum of the volume inside and outside the column.

$$V_0 = V_{\text{void}} = V_{\text{column}} + V_{\text{extra}}$$

The void volume of the column (V_{column}) is the volume between and within the pores of the individual particles, which in total form the packing material of the column. For a fixed column size, the column void volume is practically constant and independent of the diameter of the packed particles. An important source of band-broadening is, however, the volume outside the column (V_{extra}), i.e. the volume in the injection loop, the interconnecting tubing, and the detector.

All tubing used to connect the components of the system should be short, while having the smallest possible inner diameter, to minimize the band-broadening and not to destroy the efficiency obtained by a high quality column. Of course, decreasing the tubing's inner diameter has a practical limit, as the back-pressure and the risk of unintentional clogging increases accordingly. The volume between the pump and the injector is obviously of no consequence to band broadening, but it can nevertheless be impractical if it is excessive, since eluent changeover might take an unnecessarily long time.

Injection volumes

Sample injection volumes ranging from 1 to 100 μL are commonly used for analytical separations, for guidelines see the table below. When injecting fixed volumes through injection loops, minimal band broadening is obtained using longer tubes with smaller inner diameters.

In a tube with laminar flow, dispersion is proportional to the square root of the length and the square of the tube radius respectively. This is why a tube with a small inner diameter gives less band-broadening.

Suitable injection volumes
for different column inner diameters

Column i.d.	Sample volume
1 mm	0.05-1 μL
2 mm or 2.1 mm	0.2-5 μL
3 mm	1-20 μL
4 mm or 4.6 mm	5-80 μL
7.5 mm	10-150 μL
10 mm	30-500 μL
25 mm	200-3000 μL

Volume overload

Injections of excessive sample volumes will cause volume overload that will significantly decrease the separation efficiency. In extreme cases a volume overload can give flattened and grossly distorted peaks, as illustrated in the figure.

Overlay of chromatograms with increasing injection volumes

Column	50 x 4.6 mm, 5 μ m particles
Injection volumes	3 μ L 20 μ L 200 μ L

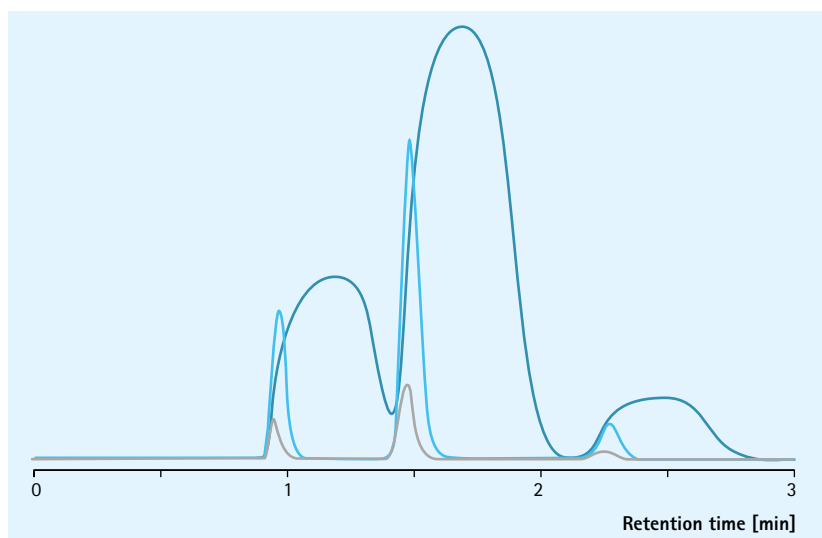

Separation efficiency

To preserve maximum separation efficiency, injection volumes should not exceed 1% of the total column volume, have a look at the figure. Also note that if 10% of the total column volume is injected, only about 20% of the column efficiency will remain.

Column efficiency for different injection volumes

Column	50 x 4.6 mm
Mobile phase	Analyte $k = 1.6$

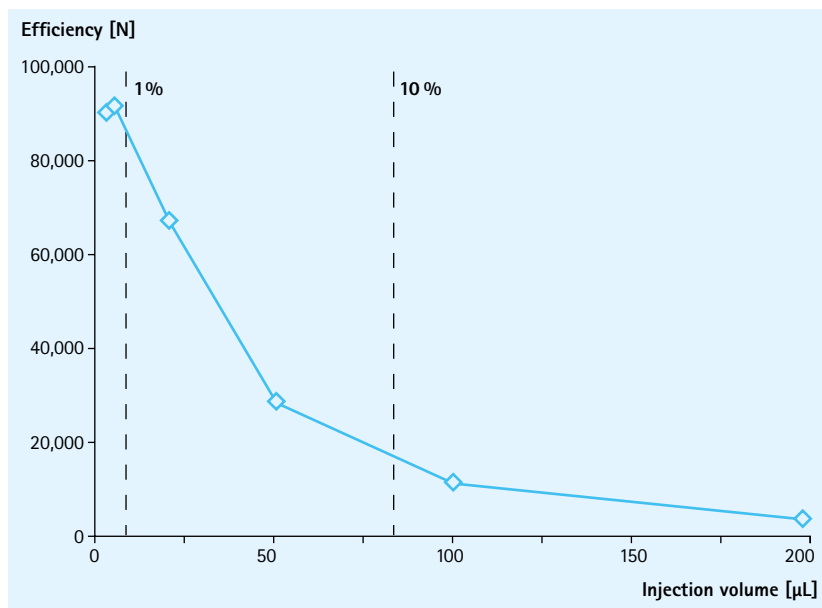

Mass overload

Injection of excessive sample mass (as differentiated from excessive sample volume) will also cause overload, which significantly decreases the separation efficiency, although in a different way. Mass overload leads to shortened retention times as well as causing non-Gaussian peaks, as illustrated in figure.

Mass overload also occurs with increasing amounts of analytes in the injected sample. The table shows recommended mass loadings per column i.d. Eluting peaks with relatively much smaller mass amounts display Gaussian shapes, but with increasing mass loading the eluting peaks assume a triangular, Langmuir (left-angled) or anti-Langmuir (right-angled) shape. This is due to the non linear part of the adsorption isotherms (non-linear chromatography). Preparative chromatography is normally deliberately carried out under overloading conditions, as opposed to analytical separations, in which the peaks retain Gaussian shapes within the linear part of the adsorption isotherm.

Recommended mass loads

Column i.d.	Sample amount
1 mm	0.05 mg
2 mm or 2.1 mm	0.2 mg
3 mm	1 mg
4 mm or 4.6 mm	5 mg
7.5 mm	10 mg
10 mm	30 mg
25 mm	200 mg

Recommended mass loads with no negative influence on the analytical column separation efficiency. The mass loadability ultimately depends on the sample complexity, solubility and retentivity, hence both less and more mass is possible to load at each column i.d.

Retention of Para-aminobenzoic acid on Chromolith® RP-18 endcapped, 100-10 mm

Column	Chromolith® RP-18 endcapped 100-10 mm
Mobile phase	Acetonitrile:water / 5:95 (v/v) Acetic acid 0.1%
Injection volume	200 µl
Sample	Dissolved in mobile phase and concentrations ranging from 0.1-50 mg/mL

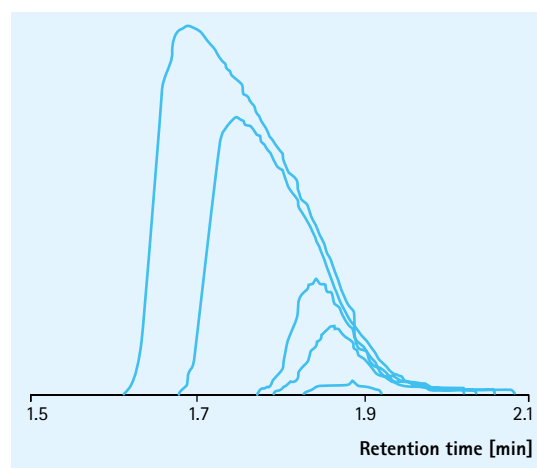

Scaling the column length

Scaling of a separation may also involve scaling of the column length, either to shorten the injection-to-injection cycle time of the assay by reducing the column length, or to achieve higher peak capacity and to be more tolerable of matrix effects. The figure illustrates separations with similar column efficiency. With a shorter column the separation is quicker, and with a longer column you can expect higher resolution and more peak capacity.

Separation of toluene, uracil and cytosine on a ZIC®-HILIC column (4.6 mm i.d)

Column	ZIC®-HILIC 4.6 mm
Mobile phase	Acetonitrile 80:20 (v/v) / Ammonium acetate buffer 25 mM, pH 6.8
Flow rate	0.5 mL/min
Sample	Toluene Uracil Cytosine

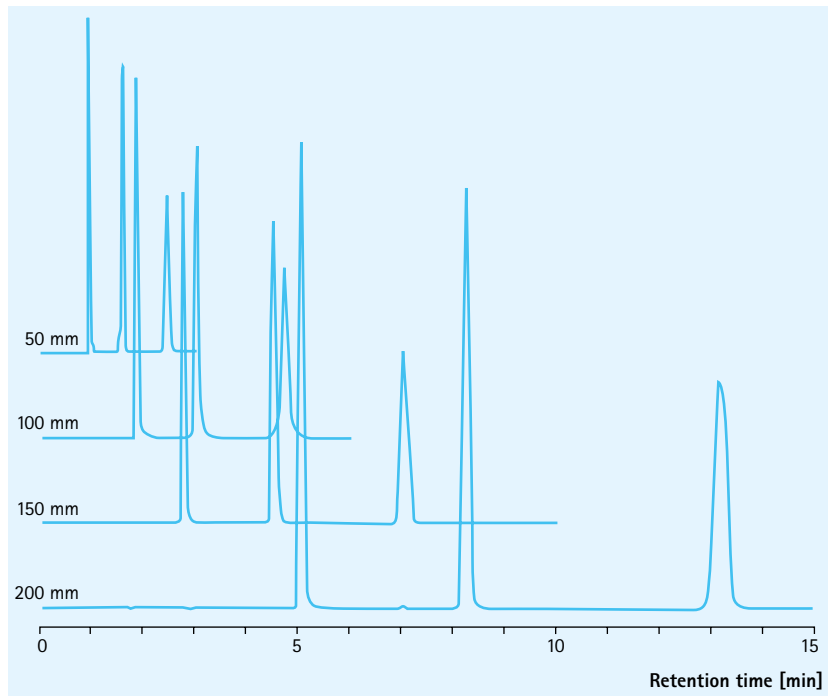

Instrumental influence

When scaling down, it is important to identify and adjust for potential instrumentation influence. In gradient mode, the user should pay attention to the overall system dwell volume, where the pump mixer may contribute a very large extra volume. This could potentially ruin any attempts in scaling a separation, with delay in the gradient profile. This effect is larger the more narrow a column i.d. is used. However, it can easily be alleviated by simply replacing the standard mixer with a smaller volume one.

Other than the potential gradient errors discussed above, the pump mixer has little influence on the chromatographic efficiency. This is not the case for detectors. In liquid chromatography, the detector is a flow-through unit, and both the actual detection technology and the design of the detector will influence the column separation capability.

The figure illustrates the result from a standard HPLC system equipped with a UV-detector operated at 0.1 mL/min and using a 150x2.1 mm column. Different injection volumes were used, 5 and 10 μL , which correspond to one and two percent of the total column volume, respectively. Both a standard (8 μL) and a semi-micro flow cell (2.5 μL) were used. For 2.1 mm and smaller i.d. columns, it is recommended to use semi-micro flow cells, whereas from 3.0 up to 7.5 mm i.d., a standard flow cell is recommended. For larger column i.d., a preparative flow cell should be used of larger volume.

Extra-column volume effects of injection and detector flow cell volumes

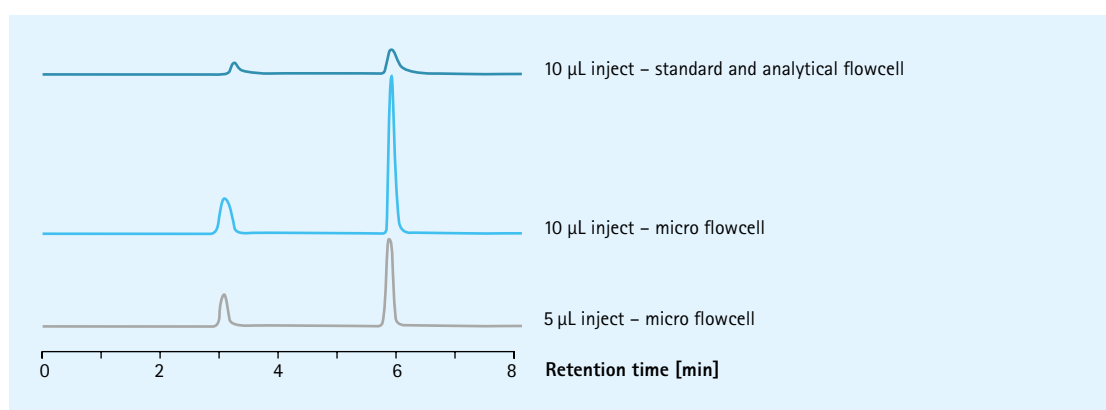

All experiments were performed on the same system using a 150-2.1 mm long column.

Up-scaling

Preparative HPLC is an indispensable tool to purify compounds for activity testing during the discovery and development process of new drugs. Depending on the amount, semi-preparative HPLC can be carried out at analytical scale on columns with 5 mm i.d. or less, or at preparative scale on much larger columns. Converting from analytical to preparative scale is often seen as a complicated and tiresome task by many users. The common view is that separation and performance for preparative HPLC columns is inferior to analytical columns. This is mainly true historically, but today several manufacturers offer truly scalable phases.

The traditional way of making an HPLC column involves slurry packing using pressure driven pumps where often the performance (both efficiency and peak asymmetry) of analytical and preparative columns differs. Slurry packing techniques suffer from friction from the column walls and how the friction helps stabilize the packed bed. Large diameter columns have less surface area per gram of stationary phase to hold it in place during the slurry decompression step. This results in reduced density and performance in the preparative columns and traditionally this makes the use of high efficiency 5 μm silica particles ineffective. Instead, 10 μm or larger materials are generally used for preparative separations.

In semi-preparative/preparative/process mode, the actual separation is mostly carried out under overload conditions (both volume and mass overload), to maximize productivity, hence it is important to have confidence that the analytical column will scale accordingly. Commonly, loadability studies are carried out in the analytical scale, to demonstrate overloading conditions and that the overloaded method will predictably scale to the larger preparative column.

There are also the obvious economical reasons for performing the initial loading studies in the analytical scale. It is more expensive to run loading studies in preparative scale: the instrumentation is more expensive; it consumes more solvents per separation and it often requires multiple injections thereby decreasing the amount of sample recovered. Though the transposed large scale method is a good starting point, at times the preparative method may need to be modified for improved efficiency. As a result, large scale separation on a preparative HPLC system can require more of the chemist's time to determine efficient loading. It is also important to keep in mind that method development or method transposition from an analytical platform to a preparative system is not always consistent due to the differences in performance of high pressure systems, column vendors, column size, and media size and type.

Scale-up calculations

There are different ways to calculate scaling up from one column to another. The equation represents one alternative.

$$\frac{X_{\text{an}}}{\pi r_{\text{an}}^2} = \frac{X_{\text{pr}}}{\pi r_{\text{pr}}^2} \cdot \frac{1}{c_L}$$

X_{an}	Flow rate in the analytical system	
X_{pr}	Flow rate in the preparative system	$X_{\text{pr}} = X_{\text{an}} \cdot r_{\text{pr}}^2 \cdot c_L / r_{\text{an}}^2$
r_{an}	Radius of analytical column	
r_{pr}	Radius of preparative column	
c_L	Length of the preparative column to length of the analytical column	
M	Substance mass	$M_{\text{pr}} = M_{\text{an}} \cdot r_{\text{pr}}^2 \cdot c_L / r_{\text{an}}^2$

Linear scaling from analytical to preparative/process scale at three different flow rates

Dimension length and inner diameter [mm]	Flow rate 1	Flow rate 2	Flow rate 3
250-4 mm	0.5 mL/min	1 mL/min	2 mL/min
250-25 mm	19.5 mL/min	39 mL/min	78 mL/min
250-50 mm	78 mL/min	156 mL/min	312 mL/min
250-100 mm	312 mL/min	625 mL/min	1250 mL/min
250-200 mm	1250 mL/min	2500 mL/min	5000 mL/min
250-300 mm	2812 mL/min	5625 mL/min	11250 mL/min

Practical examples of analytical and preparative scale purification

In the following section, examples are given for analytical separations scaled to larger scales.

The first example is scaling from 4.6 mm to 20 mm i.d. on a ZIC®-HILIC column used for separating ascorbic acid from white wine and using a large volume injection (10% of the total column volume). The analytical separation is carried out at 1.0 mL/min with an injection volume of 250 µL. Adjusting for injection volume effects, the linear scaling to a 20 mm i.d. column of same length, corresponds to a flow rate of 20 mL/min. As can be seen in the figure, the same result was obtained in both column dimensions. This example shows that it is possible to scale up on ZIC®-HILIC columns without losing resolution, which is very important for a fast scale up process without any method redevelopment.

Scaling from 4.6 to 20 mm i.d. ZIC®-HILIC column for a separation of ascorbic acid from white wine

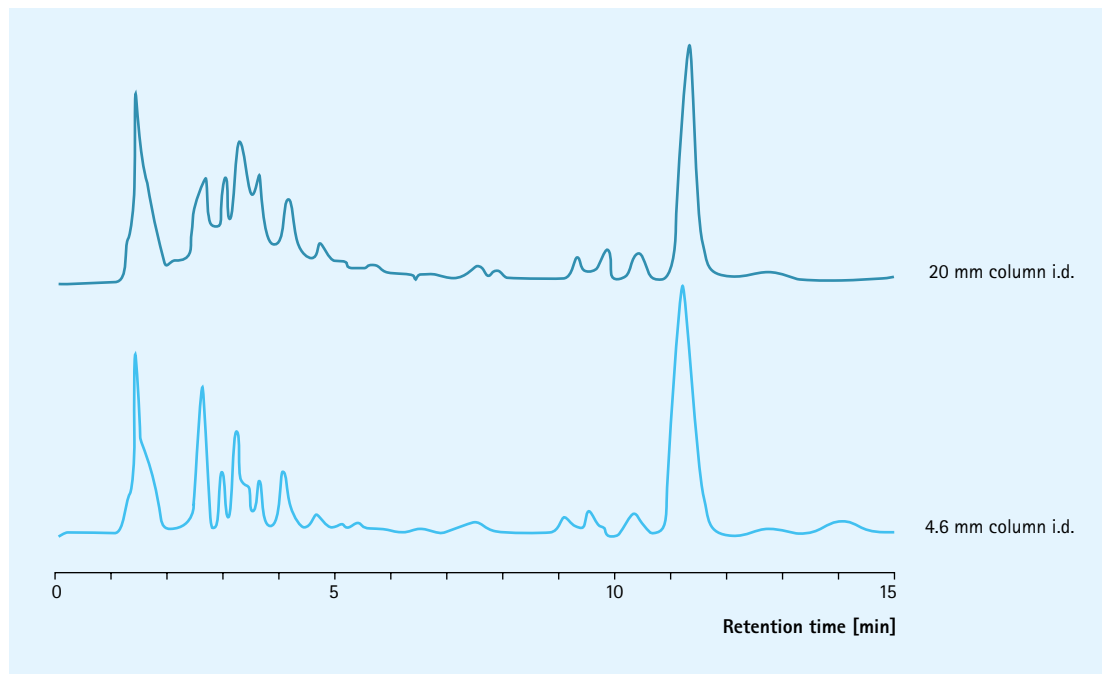

LiChroprep® application for Prostaglandins

The second example is a LiChroprep® application for Prostaglandins where an analytical scouting separation was performed at 1.5 mL/min on a 250–4 mm LiChrosorb® Si 60 with 10 µm particles.

The chromatogram (A) shows a sufficiently resolved main peak (at 7.5 minutes), hence the separation was scaled to a large i.d. column. In figure (B) the same sample (but with much higher loading) is purified at 2.0 L/min on a 600–200 mm LiChroprep® Si 60 with 25–40 µm particles. The example illustrate a flow rate scaling with consideration to the inner diameter of the column, but where the total chromatogram time is longer because the column length has been adjusted to accommodate a larger loading. In the chromatogram (B), there are also four different fractionation zones identified from which the prostaglandine purity is determined.

A. LiChrosorb® Si 60, 10 µm

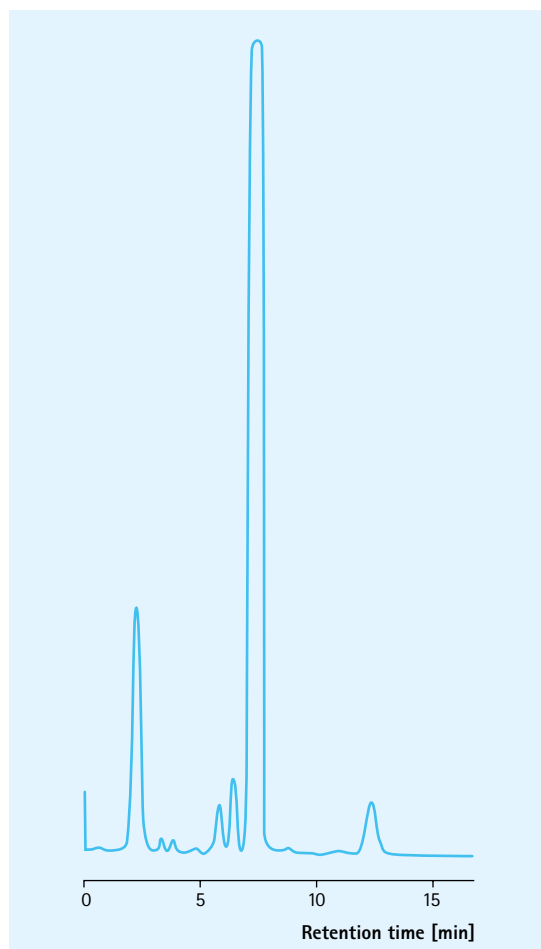

(A) Analytical scouting separation of a prostaglandin sample performed at 1.5 mL/min on a 250–4 mm LiChrosorb® Si 60 with 10 µm particles.

B. LiChroprep® Si 60, 25–40 µm

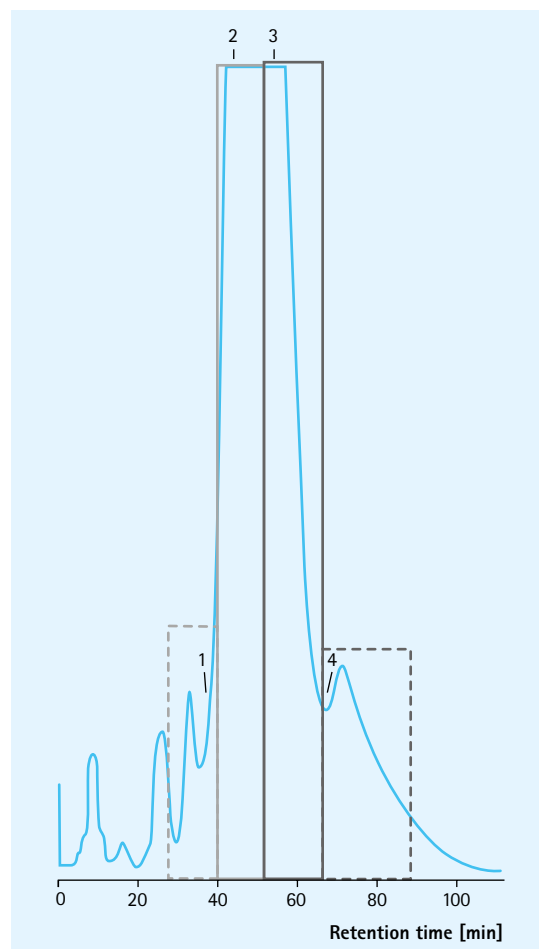

(B) Up-scaled separation of the same prostaglandin sample (but with higher loading) performed at 2.0 L/min on a 600–200 mm LiChroprep® Si 60 with 25–40 µm particles.

Alternative scaling – from TLC to preparative HPLC

During drug discovery and development, a vast amount of compounds have to be purified from extracts or combinatorial libraries for activity testing. Because of the high throughput synthesis and high throughput screening, traditional purification techniques such as preparative TLC or crystallization (low throughput), may create a bottleneck in the laboratory, but are a very useful and quick approach. This topic is not discussed in detail here, but more information can be found at the website www.merck-chemicals.com/chromatography. There you can also find information about the new exciting possibilities in combining TLC purification with mass spectrometric detection, e.g. TLC/HPTLC-DART-MS, TLC/HPTLC-MALDI-MS and TLC/HPTLC-ESI-MS, which potentially can be of great interest to the synthesis chemist. TLC has also been found to be a very quick and easy scouting method to predict optimum conditions for preparative HPLC runs.

Method transfer from TLC to Flash chromatography

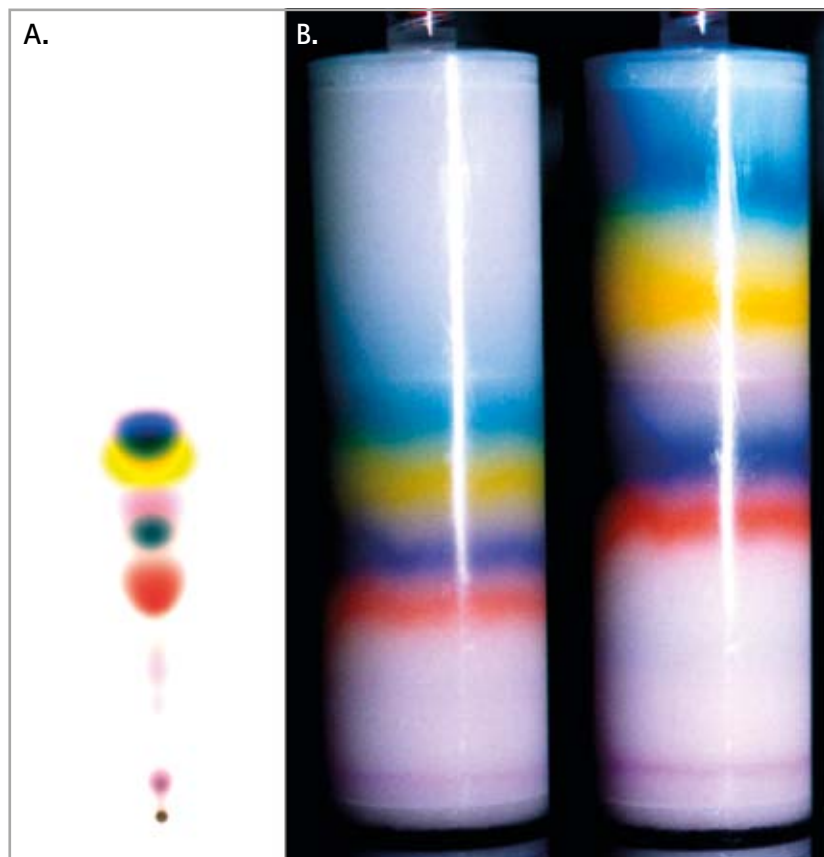

(A) Method development using TLC Silica gel 60

(B) Method transfer from TLC to Flash chromatography under same chromatographic conditions

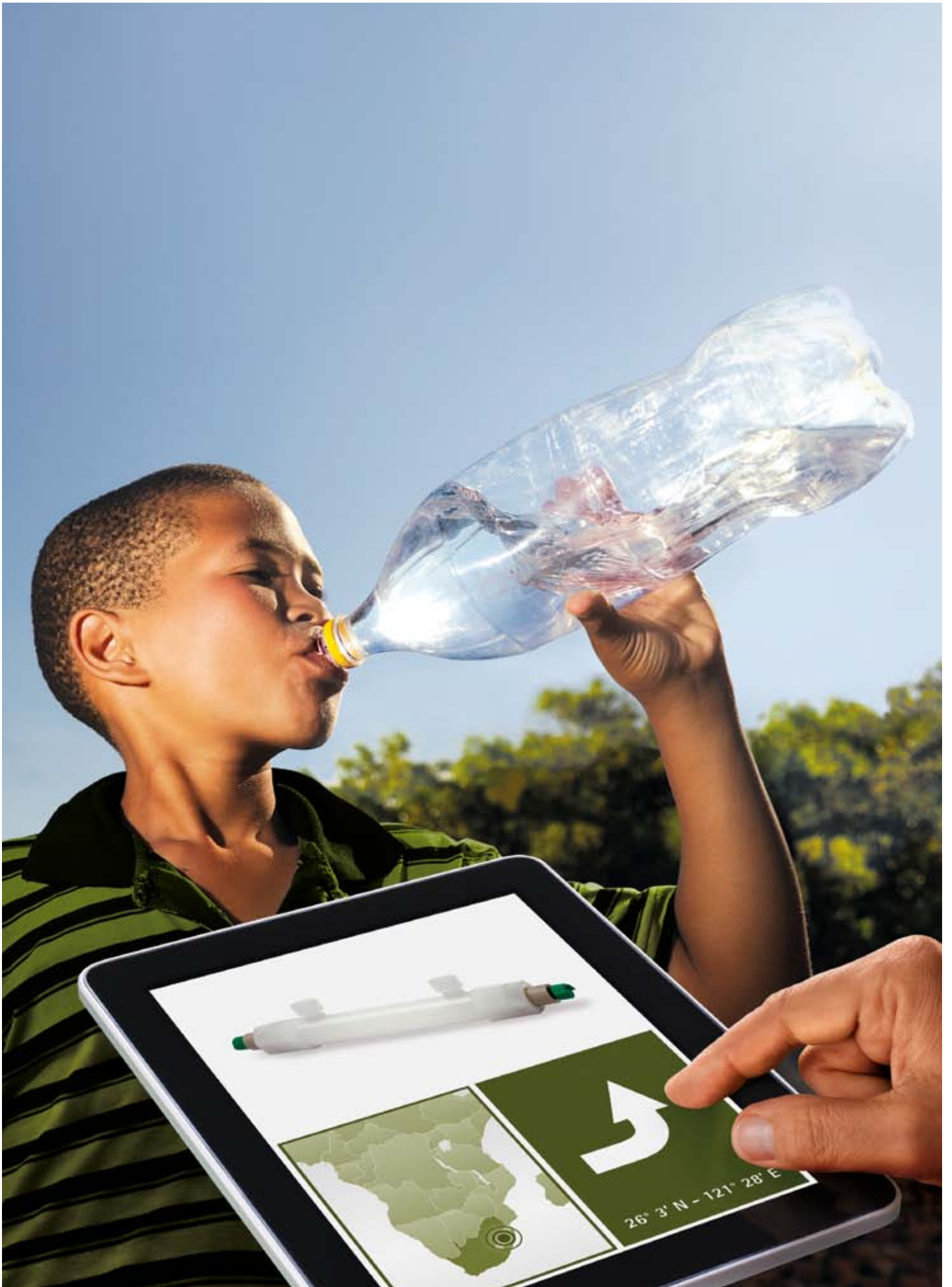

Ion Chromatography

Let us pause for a refreshment. Water: vital for our existence and pure in its essence. But looks can be deceiving. How can we be sure that it's safe to drink? Merck Millipore ion chromatography solutions are used to answer this question every day. Our suppressor systems not only help you examine drinking water, but also food, other beverages and even the environment. Offering superior detectability and simpler analysis, our products are trusted by commercial, environmental and academic organizations throughout the world. We go to extremes to ensure that when you have a glass of water in your hands, you can quench your thirst without a doubt in your mind.

Ion Chromatography

page 362

SeQuant® SAMS & CARS suppressor system
High sensitivity and low background in anion chromatography

page 363

Ion Chromatography Introduction

Ion chromatography is an important method used to verify the safety of water and food supply around the world. This technique supports numerous other applications including environmental monitoring, ensuring the secure operation of nuclear power plants, and quality control in electronic and pharmaceutical industries.

Suppressed ion chromatography has become the dominating approach in ion chromatography. The continuous chemical suppression of the eluent reduces the background while simultaneously increasing the signal for the analyte anions. As a result, it enables high sensitivity assays and trace analyses.

For enhanced detectability and simpler analysis, Merck Millipore has developed the SeQuant® SAMS membrane suppressor, which is operated using the SeQuant® CARS continuous regeneration system. The robustness and high capacity of this suppression system makes it suitable for routine analysis use as well as for high ion-strength eluents and gradient separations. To ensure smooth operation of your system for many years, a range of affordable refill and replacement products and installation accessories are also available.

SeQuant® SAMS & CARS suppressor system

High sensitivity and low background in anion chromatography

The SeQuant® CARS system is designed for optimized eluent suppression with the SAMS suppressor, regardless of flow rate and composition of the mobile phase. This warrants that the lowest possible background conductivity level and highest possible analyte sensitivity is always reached, no matter what the application is.

The CARS system with SAMS suppressor can successfully be used for standard routine operation, but due to its very high capacity and the continuous rapid regeneration of the suppressor, the system is also suitable for high ion-strength eluents and gradient elution.

SeQuant® SAMS is a chemically regenerated membrane suppressor for anion chromatography. Its operation is based on selective exchange of protons (H^+) from an external regeneration channel for cations (e.g., Na^+) from the eluent. SAMS is manufactured according to state-of-the-art in chromatographic reactor technology, and features both high transport capability and low band-broadening.



SAMS anion membrane suppressor



CARS regeneration cartridge

SeQuant® SAMS & CARS suppressor system benefits

- Low and stable background levels and high sensitivity in routine analysis
- Can be integrated with any ion chromatography system
- Suitable also for high ion-strength eluents and gradient applications

► Mobile phases and reagents for HPLC and TLC

page 15

Ordering information

Product	Ord. No.	Contents of one package
CARS Continuous Anion Regeneration System [complete system]	1.50611.0001	1 CARS pump 1 CARS cartridge – small 1 x 100 mL ULB-P regeneration solution 1 suppressor installation kit
SAMS standard Membrane suppressor for analysis in anion ion chromatography	1.50609.0001	1 suppressor 100 cm membrane, 10-32 fittings 1 fitting kit with 10-32 UNF fittings for 1/16" tubing 1 syringe
SAMS gradient Membrane suppressor for gradient analysis in anion ion chromatography	1.50610.0001	1 suppressor 200 cm membrane, 10-32 fittings 1 fitting kit with 10-32 UNF fittings for 1/16" tubing 1 syringe
CARS cartridge – small Small replacement regeneration cartridge	1.50613.0001	1 cartridge 0.5 L, capacity 0.9 eq
CARS cartridge – large Large replacement regeneration cartridge	1.50614.0001	1 cartridge 0.75 L, capacity 1.3 eq
ULB-P regeneration solution	1.50616.0100	100 mL
Pressure relief valve	1.50618.0001	1 pressure relief valve 100 psi
CARS suppressor installation kit	1.50619.0001	5 m regeneration channel tubing 6 luer fittings for regeneration channel

To get started you need the CARS System [1.50611.0001] a SAMS Suppressor [e.g., 1.50609.0001]. In addition, a pressure relief valve [1.50618.0001] is recommended.

Application example

The robust and flexible design makes it easy to integrate CARS and SAMS with any ion chromatography system. An example of results obtained with CARS and SAMS integrated with an ion chromatography system having suitable anion separation column is shown below.

Schematic diagram of the installation of CARS and SAMS in an ion chromatography system

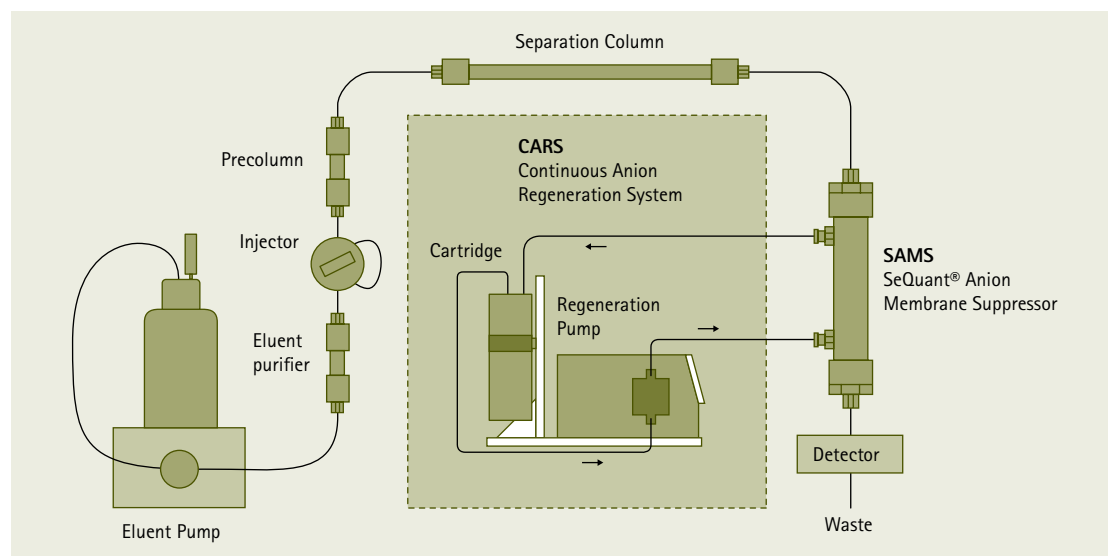

Chromatogram for isocratic separation of a mixture of inorganic anions using CARS with SAMS for suppression of the background conductivity

Eluent	1.7 mM NaHCO ₃ / 1.8 mM Na ₂ CO ₃
Flow rate	1 mL/min
Sample	20 µL of 1-30 ppm of each anion in water

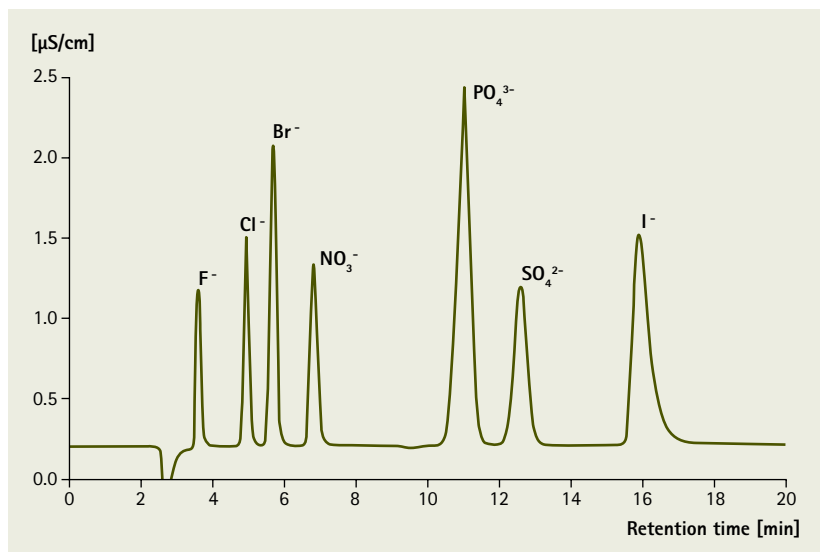

Characterization

In the SeQuant® CARS system, the eluent is suppressed in the SAMS suppressor using protons supplied by the CARS regeneration cartridge and carried there by the ULB-P regeneration solution. The CARS pump ensures stable operation of the entire system by continuously circulating the ULB-P solution.

CARS system parts

Component	Included in	Description	Task	Typical replacement interval
SAMS	1.50609.0001 1.50610.0001	Robust membrane suppressor	Exchange eluent cations (e.g., Na ⁺) to protons (H ⁺).	12-24 months Depending on amounts of samples and their purity
CARS pump	1.50611.0001	Circulation pump	Ensure continuous and stable delivery of the ULB-P throughout the system	Not applicable Only normal instrument service required
CARS regeneration cartridge	1.50611.0001 1.50613.0001 1.50614.0001	High-capacity source of protons	Supply protons (H ⁺) to the SAMS suppressor	6-12 months Depending on hours of use, eluent strength and flow rate
ULB-P regeneration solution	1.50611.0001 1.50616.0100	Ultra-pure liquid ion exchanger	Carry protons (H ⁺) from the cartridge to the suppressor, and eluent cations (e.g., Na ⁺) back to the cartridge	6-12 months Typically replaced when a new cartridge is installed or if the system becomes contaminated
Pressure relief valve	1.50618.0001	Safety valve for suppressor	Insure SAMS against high detector pressure	Not applicable
CARS suppressor installation kit	1.50611.0001 1.50619.0001	Tubing kit	Tubing for the ULB-P circulation	Not applicable

Typical suppression performance and cartridge lifetime of CARS with SAMS in an ion chromatographic system. The example is based on the standard type SAMS and the standard type CARS cartridge (0.5 L, 0.9 eq).

Eluent type	NaOH mM	Na ₂ CO ₃ mM	NaHCO ₃ mM	Flow rate mL min ⁻¹	Conductivity μS cm ⁻¹	Expect. cartridge lifetime full 8-hour working days
10	–	–	–	1.0	< 3	170
–	–	2.4	3.0	1.0	15-20	210
–	–	2.4	3.0	2.0	15-20	105

Schematic illustration of the ion exchange processes within SAMS and CARS

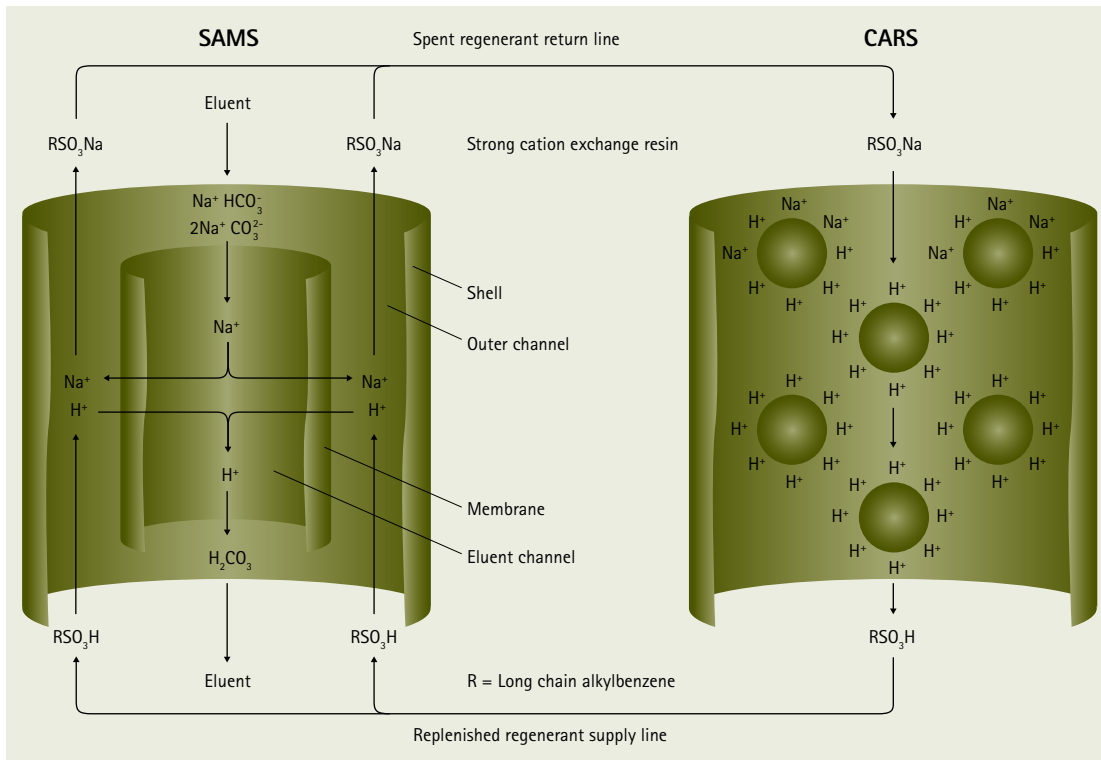

In the SAMS suppressor (left), eluent cations (Na^+) are replaced by protons (H^+) in an ion exchange process over the suppressor membrane. The protons (H^+) are carried to the outer channel of the SAMS suppressor by the ULB-P regeneration solution (bottom, RSO_3H). After the ion exchange process, the ULB-P solution (top, RSO_3Na) returns to the CARS regeneration cartridge (right) and deposits the former eluent cations (Na^+), while acquiring new protons (H^+) from the ion exchange resin. The process can be continuously repeated until the CARS regeneration cartridge is depleted of protons.

For the most up-to-date information, products and applications, please visit www.sequant.com and ask for your free copy of the booklet **A Practical Guide to Ion Chromatography**.



50° 24' N - 30° 17' E

Gas Chromatography

Sometimes, the best place to learn more about the earth is in the air. That's where we now find ourselves, floating above a field in order to analyze the quality of agricultural products. Merck Millipore plays an important role here as well, with a variety of solvents, standards and sorbents for gas chromatography. Our portfolio of state-of-the-art high-purity products, such as SupraSolv[®], helps ensure that a farm's produce is free of pesticide and trace residues. So the next time you're eating vegetables, you'll be getting lots of vitamins – and nothing else.

07

Contents

Gas Chromatography

page 371

High purity solvents for gas chromatography

page 372

SupraSolv®
Solvents for gas chromatography

page 373

SupraSolv®
Solvents for headspace gas chromatography

page 376

UniSolv®
Solvents for organic trace analysis

page 378

Sorbents for packed columns

page 382

Derivatization reagents

page 383

Reference substances

page 385

Gas Chromatography

Introduction

Despite numerous developments in analytical chemistry, gas chromatography remains one of the most frequently used analytical techniques. Its application spans an extensive range of fields, including medicine, biology, environmental sciences as well as industrial production. No other analytical method can combine resolving power with analysis speed and sensitivity.

Provided that the sample has sufficient volatility and thermal stability in the selected temperature region, gas chromatography is the method of choice. Besides qualitative and quantitative information contained in the chromatogram, gas chromatography (GC) can be easily combined with spectrometric techniques for structure confirmation or selective detection, such as in GC-MS (mass spectrometry).

The performance of columns and chromatographic equipment has steadily advanced. A major breakthrough was the invention of capillary columns by Golay in 1958. The introduction of flexible fused silica columns by Dandeneau and Zerenner in 1979 greatly influenced the acceptance of capillary columns. Compared to packed columns, capillary columns provide superior resolution in a shorter analysis time. Therefore, capillary columns have become the preferred tool for analytical work.

A wide range of universal and selective detectors with well adapted solvents (high purity solvents) are available, many of them eminently suited for residue and trace analysis. Autosamplers, that can run unattended, provide very good precision in sample introduction. Quantitative GC-results can be very accurate.

For all the reasons summed up above, it is clear that GC is the method of choice, provided that the sample has sufficient volatility and thermal stability in the selected temperature region.

The chromatography products from Merck Millipore are not intended for use as medical devices for in-vitro diagnostic testing of human specimens within the meaning of European Directive 98/79/EC. They are for research purposes only, for investigating in-vitro samples without any medical objective.

High purity solvents for gas chromatography

Tailor-made solvents for gas chromatography

GC-Analysis comprises sample preparation, such as extraction and concentration of the extracts before injection. Solvents are necessary with the highest possible degree of purity. SupraSolv® and UniSolv® are the GC solvents of high batch consistency for all trace and environmental analyses.

They provide the analyst with the security and reliability so necessary for today's applications, especially when monitoring and determining environmentally relevant substances in soil and water samples, e.g. polycyclic aromatic hydrocarbons (PAH), polychlorinated biphenyls (PCB), polychlorinated dibenzodioxins (PCDD), pesticides, but also highly volatile chlorinated hydrocarbons (HVHC) present in ppb trace amounts only.

Whilst the demands placed on the selectivity and sensitivity of the detection procedures used for environmental pollutants are constantly increasing, the results obtained may be adversely affected by the tiniest traces of impurities in the solvents used. The specifications of the solvents have been especially adapted to the particular area of application.

- SupraSolv® for gas chromatography
- UniSolv® for organic trace analysis

Solvents for gas chromatography

Brand name	Application	Instrumentation
SupraSolv® for gas chromatography	<ul style="list-style-type: none">• Sample preparation• Analysis of medium to high boiling substances (e.g. pesticides)	<ul style="list-style-type: none">• Gas chromatography• Suitable for detection: GC-ECD
UniSolv® for organic trace analysis	<ul style="list-style-type: none">• "ONE FOR ALL"• Sample preparation• Analysis of low to high boiling substances (e.g. waste water and/or soil analysis)	<ul style="list-style-type: none">• Gas chromatography• Suitable for detection: GC-ECD / GC-FID / GC-MS

SupraSolv[®] solvents for gas chromatography

With gas chromatography, only solvents with the highest levels of purity are suitable for sample preparation tasks. SupraSolv[®] solvents are developed specially for GC-ECD detection, and offer the largest ECD retention time window and a minimal signal-to-noise ratio. Typical applications include the determination of polychlorinated biphenyls (PCB) in water and soil or pesticides in fruits and vegetables.

SupraSolv[®] the reliable solution for GC-ECD

SupraSolv[®] has minimal interference signals in the relevant retention time window. This ensures reliable, reproducible and accurate analysis results. Thanks to outstanding batch consistency, SupraSolv[®] also saves you time and money by making repeat analyses a thing of the past.

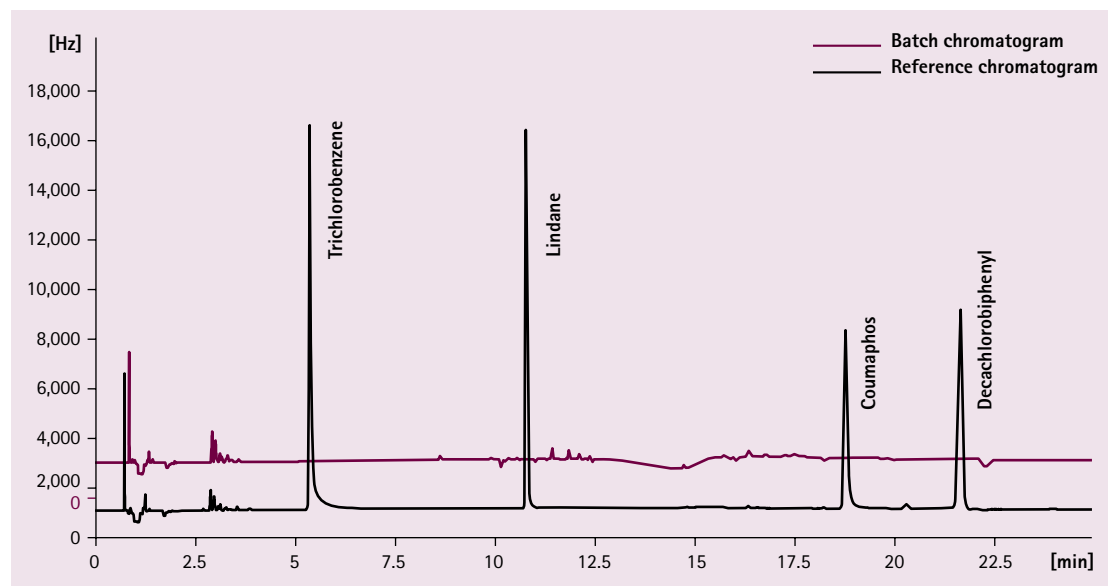

GC-ECD, batch and reference chromatogram (Lindane = 3 pg/ml), *n*-Hexane SupraSolv[®] (104371)

► Solvent withdrawal
systems
page 25

SupraSolv® solvents for gas chromatography

Ordering information – SupraSolv® solvents for gas chromatography A-0

Product	Ordering No.	Content / Packaging	Purity (GC) min. [%]	Evap. residue max. [mg/L]	Water max. [%]	Color max. [Hazen]
Acetone	1.00012.1000	1 L GL	99.8	3.0	0.05	10
	1.00012.2500	2.5 L GL				
	1.00012.4000	4 L GL				
	1.00012.9030	30 L ST				
Acetonitrile	1.00017.1000	1 L GL	99.8	3.0	0.05	10
	1.00017.2500	2.5 L GL				
	1.00017.4000	4 L GL				
tert-Butyl methyl ether	1.01995.1000	1 L GL	99.8	3.0	0.02	10
	1.01995.2500	2.5 L GL				
Chloroform, stabilized	1.02432.1000	1 L GL	99.8	5.0	0.01	10
	1.02432.2500	2.5 L GL				
Cyclohexane	1.02817.1000	1 L GL	99.8	3.0	0.01	10
	1.02817.2500	2.5 L GL				
	1.02817.4000	4 L GL				
	1.02817.9010	10 L ST				
Dichloromethane	1.06054.1000	1 L GL	99.8	5.0	0.01	10
	1.06054.2500	2.5 L GL				
	1.06054.4000	4 L GL				
	1.06054.9010	10 L ST				
Diethyl ether, stabilized	1.00931.1000	1 L GL	98.0	3.0	0.05	10
	1.00931.2500	2.5 L GL				
	1.00931.4000	4 L GL				
N,N-Dimethylformamide	1.10983.1000	1 L GL	99.8	3.0	0.05	10
	1.10983.2500	2.5 L GL				
Ethyl acetate	1.10972.1000	1 L GL	99.8	3.0	0.02	10
	1.10972.2500	2.5 L GL				
	1.10972.4000	4 L GL				
	1.10972.9010	10 L ST				
	1.10972.9030	30 L ST				
n-Hexane	1.04371.1000	1 L GL	98.0*	3.0	0.01	10
	1.04371.2500	2.5 L GL				
	1.04371.4000	4 L GL				
	1.04371.9010	10 L ST				
	1.04371.9030	30 L ST				
Isohexane	1.04340.2500	2.5 L GL	99.8	3.0	0.01	10
Isooctane	1.15440.1000	1 L GL	99.8	3.0	0.01	10
	1.15440.2500	2.5 L GL				
Methanol	1.06011.1000	1 L GL	99.8	3.0	0.1	10
	1.06011.2500	2.5 L GL				
	1.06011.4000	4 L GL				

GL = glass bottle | ST = stainless steel barrel | * Sum of hexane isomers + methylcyclopentane (GC) ≥ 99.8%



Ordering information – SupraSolv® solvents for gas chromatography P-Z

Product	Ordering No.	Content / Packaging	Purity (GC) min. [%]	Evap. residue max. [mg/L]	Water max. [%]	Color max. [Hazen]
Petroleum benzine (40 – 60 °C)	1.01772.1000	1 L GL	–	3.0	0.01	10
	1.01772.2500	2.5 L GL				
	1.01772.4000	4 L GL				
	1.01772.9010	10 L ST				
	1.01772.9030	30 L ST				
2-Propanol	1.00998.1000	1 L GL	99.8	3.0	0.1	10
	1.00998.2500	2.5 L GL				
Toluene	1.08389.1000	1 L GL	99.8	3.0	0.03	10
	1.08389.2500	2.5 L GL				
	1.08389.4000	4 L GL				
	1.08389.9010	10 L ST				

GL = glass bottle | ST = stainless steel barrel

Please have a look at the solvent withdrawal systems on page 25 for more specific information.



SupraSolv[®] solvents for headspace gas chromatography



For the analysis of residual solvents in actives, excipients and drug products according to ICH, Ph Eur and USP

Headspace gas chromatography is a precise, well-accepted method for the analysis of residual solvents in drug substances and products. It is recommended as the preferred method of analysis for this application by the European Pharmacopeia (Chapter 2.4.24) and the United States Pharmacopeia (Chapter 467).

The ICH (International Conference on Harmonization of Technical Requirements for Registration of Pharmaceuticals for Human Use) Guideline Q3C "Impurities: Guideline for Residual Solvents" divides all residual solvents into three classes according to their harmfulness for human health, and defines permissible maximum concentrations in actives, excipients and drug products. Both, the European and the United States Pharmacopeia refer to this guideline.

When you use headspace gas chromatography to analyze residual solvents in actives, excipients and drug products, residual impurities in the solvent you choose for sample preparation can seriously affect the quality of your results. Accurate analysis demands the use of very pure solvents with extremely low concentrations of the defined residual solvents. SupraSolv[®] headspace solvents are specially designed for the analysis of residual solvents according to Ph Eur and USP. We have developed them in close cooperation with an experienced headspace laboratory, and manufacture them using special production processes. By specifying the concentrations of all residual solvents of the three defined classes in the ICH guideline, Merck Millipore offers a precise purity window for this application – for unique, application-orientated quality. Since we also perform a headspace application test on each batch, every delivery gives you the reliability, accuracy and analytical safety you need.



Extract of specification

Every residual solvent of class 1 according to ICH	≤ 1 µg/g
Every residual solvent of class 2 according to ICH	≤ 10 µg/g
Every residual solvent of class 3 according to ICH	≤ 50 µg/g

ICH = International Conference on Harmonisation of Technical Requirements for Registration of Pharmaceuticals for Human Use

Ordering information – SupraSolv[®] Headspace for the analysis of residual solvents according to ICH, Ph Eur and USP

Product	Ordering No.	Content / Packaging	Purity (GC) min. [%]	Evap. residue max. [mg/L]	Water max. [%]	Color max. [Hazen]
N,N-Dimethylformamide	1.00202.1000	1 L GL	99.8	3.0	0.05	10
	1.00202.2500	2.5 L GL				
Dimethyl sulfoxide	1.01900.1000	1 L GL	99.8	3.0	0.05	10
	1.01900.2500	2.5 L GL				



GL = glass bottle

SupraSolv® solvents for headspace gas chromatography

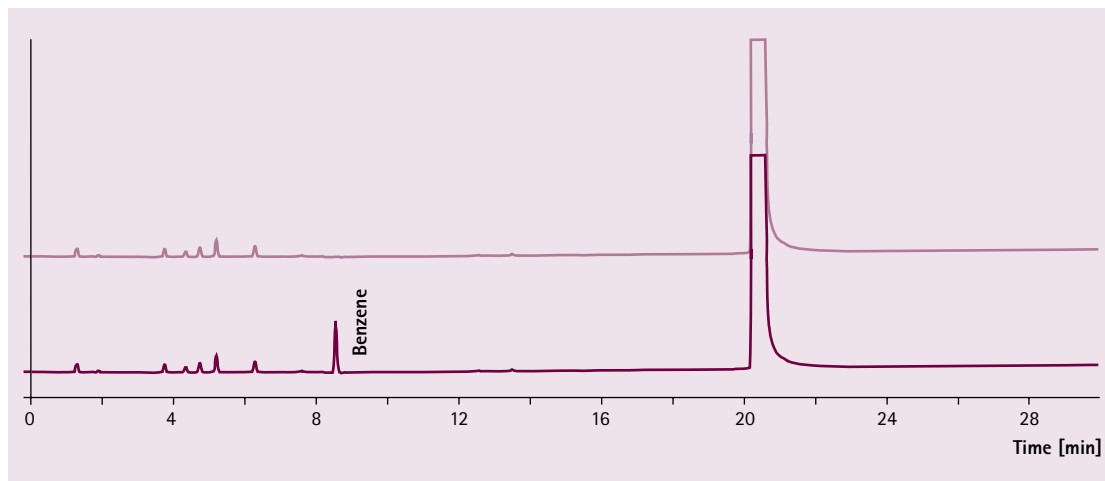

Chromatogram of DMSO Headspace SupraSolv® (101900) without addition compared to a chromatogram of DMSO Headspace SupraSolv® (101900) with 0.8 ppm benzene standard

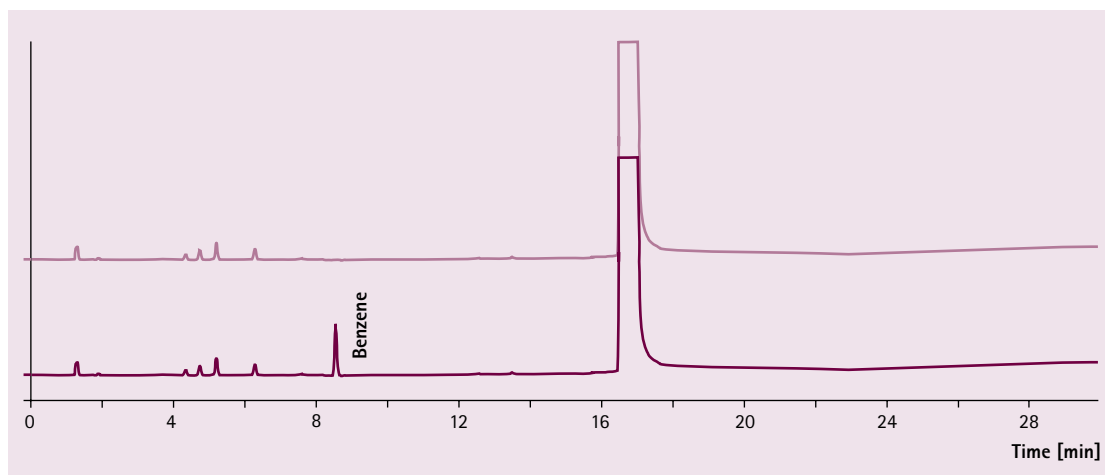

Chromatogram of DMF Headspace SupraSolv® (100202) without addition compared to a chromatogram of DMF Headspace SupraSolv® (100202) with 0.8 ppm benzene standard

UniSolv[®] solvents for organic trace analysis



UniSolv[®] is the unique solution for all applications. Its specification is even broader and higher than that of SupraSolv[®]: The specified retention time range is larger (so even low-boiling substances can be reliably detected), and the permissible concentration of interference signals within the retention time range is lower too.

We recommend UniSolv[®] for all areas that demand the highest levels of reliability in analytical results – for example, environmental analyses. Intensive research – combined with ongoing product development – not only ensures reliability in standard applications, but also permits easier, more precise analyses in new fields, such as determining the Hydrocarbon-oil index of water and soil samples.



Ordering information – UniSolv[®] solvents for organic trace analysis

Product	Ordering No.	Content / Packaging	Purity (GC) min. [%]	Evap. residue max. [mg/L]	Water max. [%]	Color max. [Hazen]
Dichloromethane	1.06454.1000	1 L GL	99.9	3.0	0.005	10
n-Hexane	1.04369.1000	1 L GL	99.0*	3.0	0.005	10
	1.04369.2500	2.5 L GL				
	1.04369.9010	10 L ST				
n-Pentane	1.07288.1000	1 L GL	99.9	3.0	0.01	10
	1.07288.2500	2.5 L GL				
Petroleum benzine (40 – 60 °C)	1.16740.1000	1 L GL	–	3.0	0.005	10
	1.16740.2500	2.5 L GL				
Toluene	1.08388.1000	1 L GL	99.9	3.0	0.005	10
	1.08388.2500	2.5 L GL				

GL = glass bottle | ST = stainless steel barrel | * Sum of hexane isomers + methylcyclopentane (GC) ≥ 99.9%

Pesticide residue analysis in apple juice

Juice manufacturers need to check the marketability of their products continuously – for example, by analyzing all the ingredients. Around 500 different pesticides are detectable in juices, and strict national and international regulations govern maximum permissible concentrations.

Classical pesticide residue analysis is still performed with GC-ECD and SupraSolv[®] solvents n-Hexane, Ethyl acetate, Dichloromethane or Acetone. The new, faster method according Anastassiades (QuEChERS) uses GC-MS instead. This method reduces manual effort, improves analytical safety, and extends the range of detectable pesticides. The extraction agent with the best dissolution properties for pesticides is Dichloromethane UniSolv[®] [106454]. Have a look at the figure on the next page.



► Solvent withdrawal systems

page 25

Pesticide residue analysis in apple juice with GC-MS and Dichloromethane UniSolv®

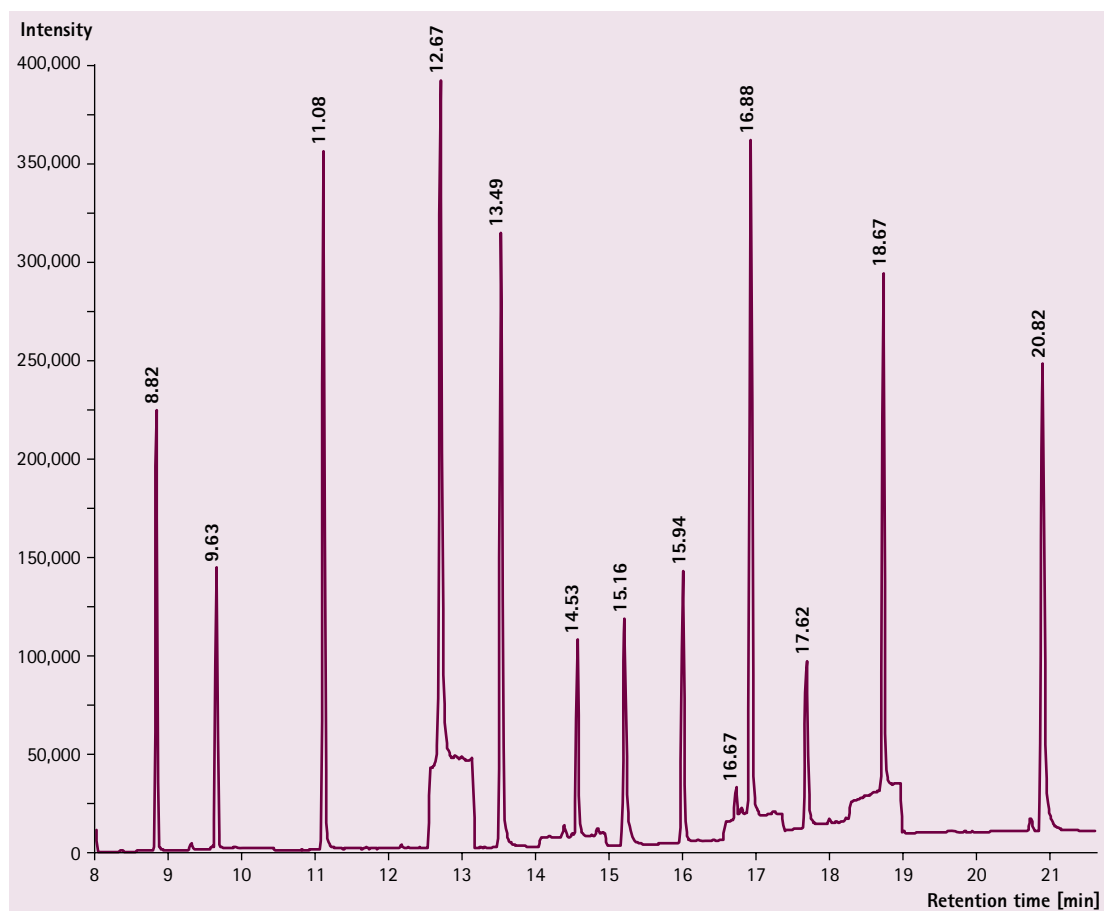

Sample chromatogram (TIC) – Apple juice spiked. Sample preparation via liquid-liquid-extraction with EXtrelut® NT 20.

Eluting solvent	Dichloromethane UniSolv® [106454]
Instrumentation	Agilent 7890A
Autosampler	Gerstel MPS
Capillary column	Phenomenex, ZB-MultiResidue; 30 m, 0.25 mm id, 0.25 µm ft
Carrier gas	Helium; constant flow
Injector	CIS 4 (cooled injection system, Gerstel)
Injection volume	2 µl
Detector	MSD 5975C, inert XL MSD triple axis detector

Sample			
RT [min]	Active substance	RT [min]	Active substance
8.82	Trifluralin	15.94	Etoxazol
9.63	Profluralin	16.67	lambda-Cyhalothrin
11.08	Pirimiphos-methyl	16.88	
12.67	Procymidon	17.62	Fenarimol
13.49	p,p'-DDE	18.67	Halfenprox
14.53	Trifloxystrobin	20.82	Azoxystrobin
15.16	Quinoxifen		

UniSolv® solvents for organic trace analysis

UniSolv® – the unique and universal solvent for all your GC applications

No matter which gas chromatography method you use, and regardless of whether you are analyzing soil or water samples: With UniSolv® you only need to use a single quality. UniSolv® is specified for GC-ECD and GC-FID, and also for mass spectroscopy (MS), which is rapidly growing in importance for the structure determination and quantification of sample components.

Gas Chromatography – Electron Capture Detector [GC-ECD]

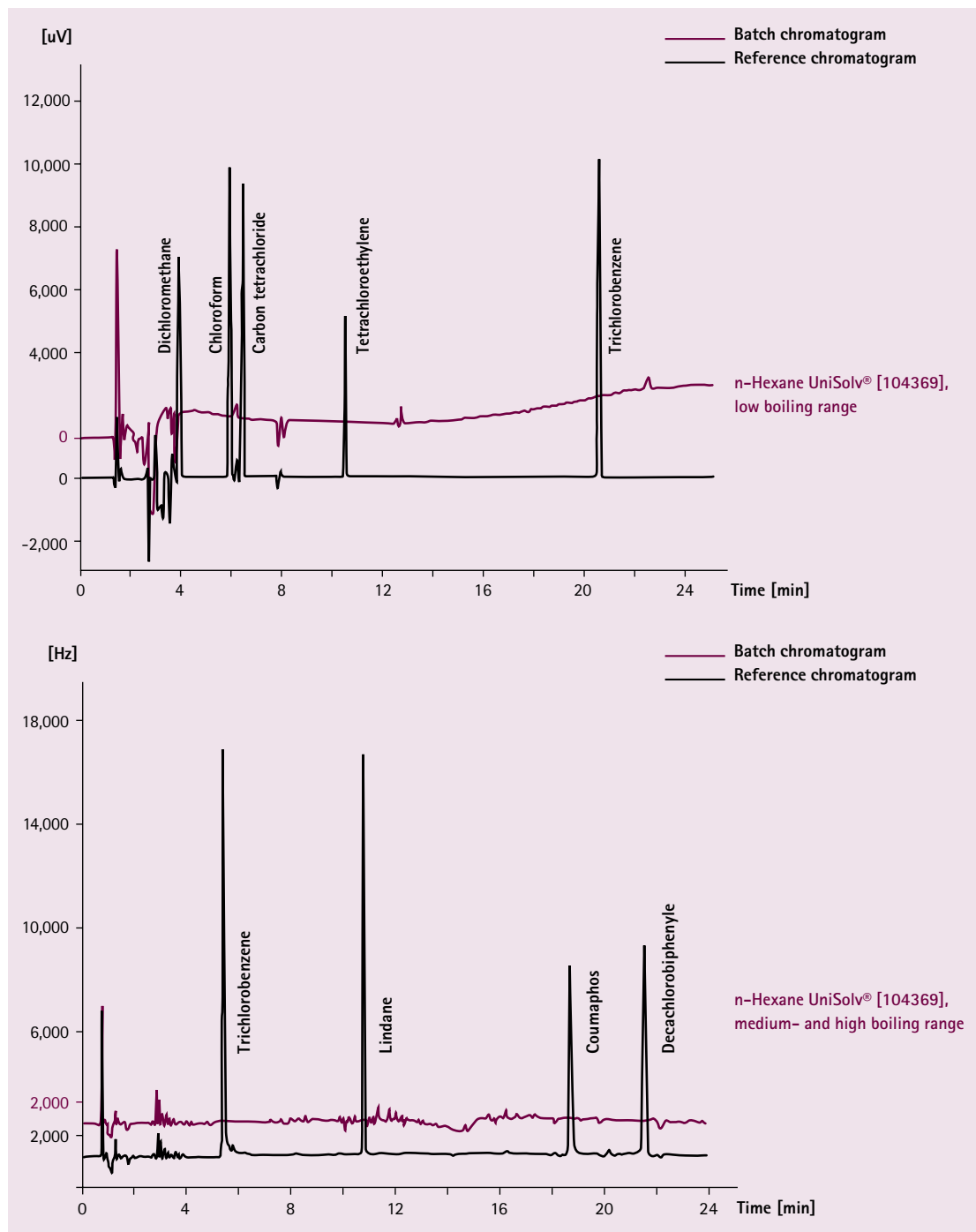

Gas Chromatography – Flame Ionization Detector [GC-FID]

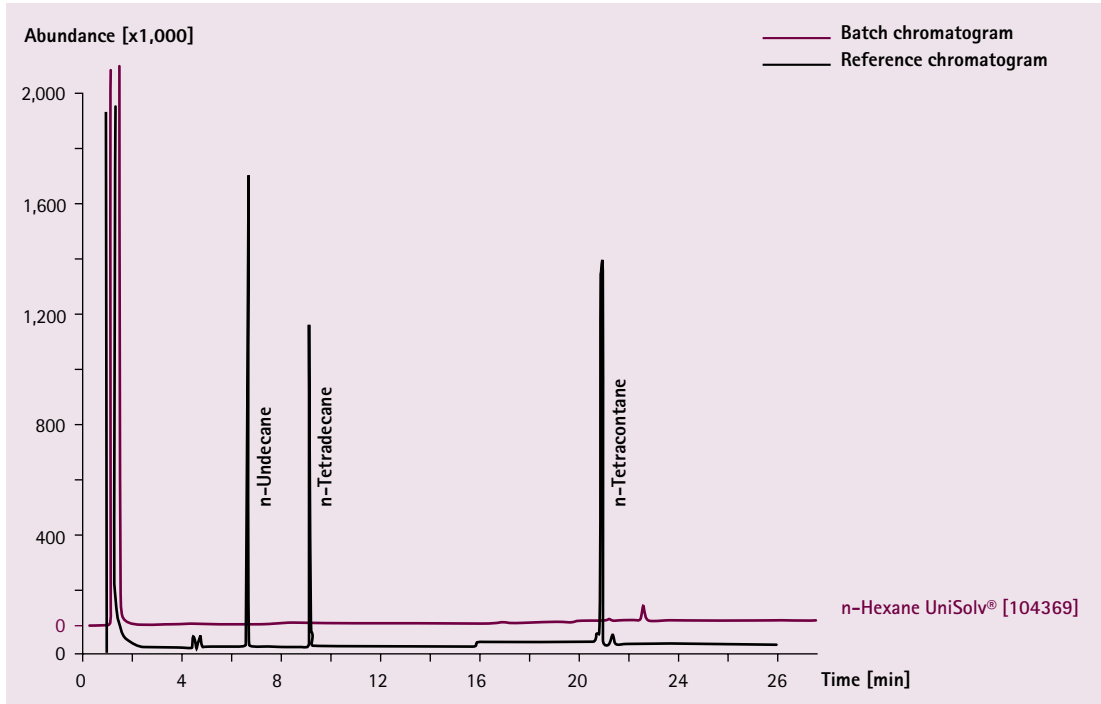

Gas Chromatography – Mass Spectrometry [GC-MS]

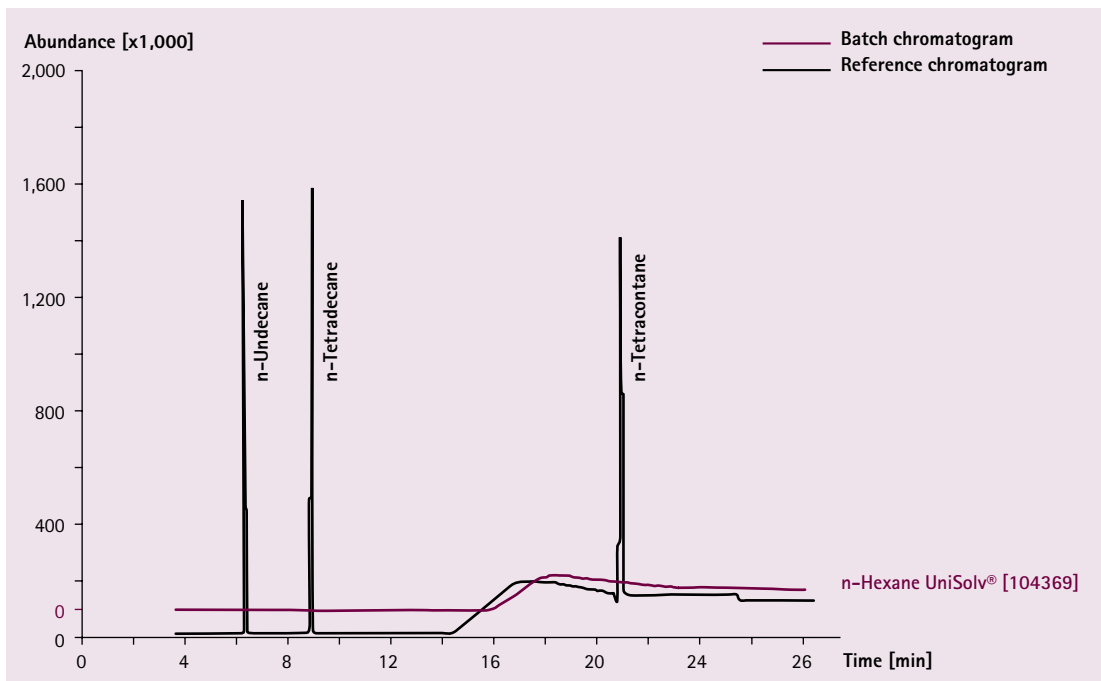

Sorbents for packed columns

The chromatographic column can be filled with an adsorbent (Gas-Solid Chromatography, GSC). For GSC the most frequently used adsorbent is active charcoal.

Active charcoal



Ordering information – Sorbents for Gas-Solid Chromatography, active charcoal

Product	Ordering No.	Particle size [mm]	Particle size [mesh]	Package	Content
Active charcoal	1.09631.0100	0.3 - 0.5	35 - 50	Glass	100 g
Active charcoal	1.09631.0500	0.3 - 0.5	35 - 50	Glass	500 g
Active charcoal	1.09624.0100	0.5 - 1.0	18 - 35	Glass	100 g
Active charcoal	1.09624.0500	0.5 - 1.0	18 - 35	Glass	500 g

Ordering information – Liquid stationary phases

Product	Ordering No.	Solvent	Temperature range [°C]	Package	Content
Dimethyl sulfoxide	1.09678.0100	Acetone	0 - 40	Glass	100 mL
Dinonyl phthalate	1.09669.0100	Acetone / Chloroform	20 - 130	Glass	100 mL
Polyethylene glycol 400 (Carbowax 400)	1.09726.0100	Chloroform	40 - 90	Glass	100 mL
Polyethylene glycol 1000 (Carbowax 1000)	1.09729.0100	Chloroform	40 - 130	Glass	100 g
Polyethylene glycol 4000 (Carbowax 4000)	1.09727.0100	Chloroform	50 - 150	Plastic	100 g
Silicone oil 550	1.09762.0100	Chloroform	20 - 130	Glass	100 mL
Squalane	1.09766.0100	Chloroform	20 - 120	Glass	100 mL
Triton® X-100	1.12298.0101	Methanol	20 - 180	Glass	100 mL
Triton® X-100	1.12298.1001	Methanol	20 - 180	Glass	1 L

Derivatization reagents

Many substances e.g. readily decomposed or with low volatility can only be investigated chromatographically after conversion to stable, readily volatile derivatives. In many cases, however, a derivatization reaction serves to increase the sensitivity of detection.

The following table provides an overview of the fields of application of the various derivatization reagents provided by Merck Millipore. The table contains acylating, alkylating and silylating reagents and also several ancillary reagents.

Application fields of the derivatization reagents

Substances Reagent	Alcohols	Amines	Carboxylic acids
Bis(trimethylsilyl) acetamide	•	•	•
Bis(trimethyl) trifluoroacetamide	•	•	•
Chlorotrimethylsilane	•	•	•
Heptafluorobutyric anhydride	•	•	–
Hexamethyldisilazane	•	•	–
N-Methyl-bis(trifluoroacetamide)	•	•	–
N-Methyl-N-(trimethylsilyl)-trifluoro acetamide	–	–	–
Trifluoroacetic anhydride	•	•	–
N-(Trimethylsilyl) acetamide	•	•	•
N-(Trimethylsilyl) diethylamine	•	•	–
N-(Trimethylsilyl) imidazole	–	•	•

Derivatization reagents

Ordering information – Derivatization reagents, silylation

Product	Ordering No.	Package	Content
Bis(trimethylsilyl) acetamide, BSA	1.09649.0010	Glass	10 mL
Bis(trimethylsilyl) acetamide, BSA	1.09649.0025	Glass	25 mL
Bis(trimethylsilyl) trifluoroacetamide, BSTFA	1.10255.0005	Glass	5 mL
Bis(trimethylsilyl) trifluoroacetamide, BSTFA	1.10255.0025	Glass	25 mL
Chlorotrimethylsilane, TMCS	1.02333.0100	Glass	100 mL
Chlorotrimethylsilane, TMCS	1.02333.0250	Glass	250 mL
1,1,1,3,3,3-Hexamethyldisilazane, HMDS	1.12186.0025	Glass	25 mL
1,1,1,3,3,3-Hexamethyldisilazane, HMDS	1.12186.0100	Glass	100 mL
Hexamethyldisiloxane	1.04500.0100	Glass	100 mL
N-Methyl-N-(trimethylsilyl)2,2,2-trifluoroacetamide, MSTFA	1.11805.0005	Glass	5 mL
N-(Trimethylsilyl)imidazole, TMSI	1.09771.0005	Glass	5 mL

Ordering information – Derivatization reagents, acylation

Product	Ordering No.	Package	Content
Trifluoroacetic anhydride, TFAA	1.12513.0010	Glass	10 mL

Reference substances

Reference substances can be used for the identification of unknown compounds in a gas chromatogram or as standards in quantitative GC analysis. They serve also for the characterization of GC column properties.

Reference substances benefits:

- Largely free from isomers
- Particularly pure substances
- Assay usually over 99.5%

Merck Millipore offers a broad range of particularly pure substances as reference substances for GC. The great majority of those reference substances are completely synthetic in origin and, hence, largely free from isomers that are difficult to separate by GC. Their assay is generally greater than 99% usually over 99.5 or 99.7%.

To ensure highest quality each pack comes with a gas chromatogram which was generated under appropriate test conditions. The reference substances belonging to the hydrocarbon group are packed in pierceable ampoules, the fatty acid methyl esters and other reference substances in screw-capped glass vials.

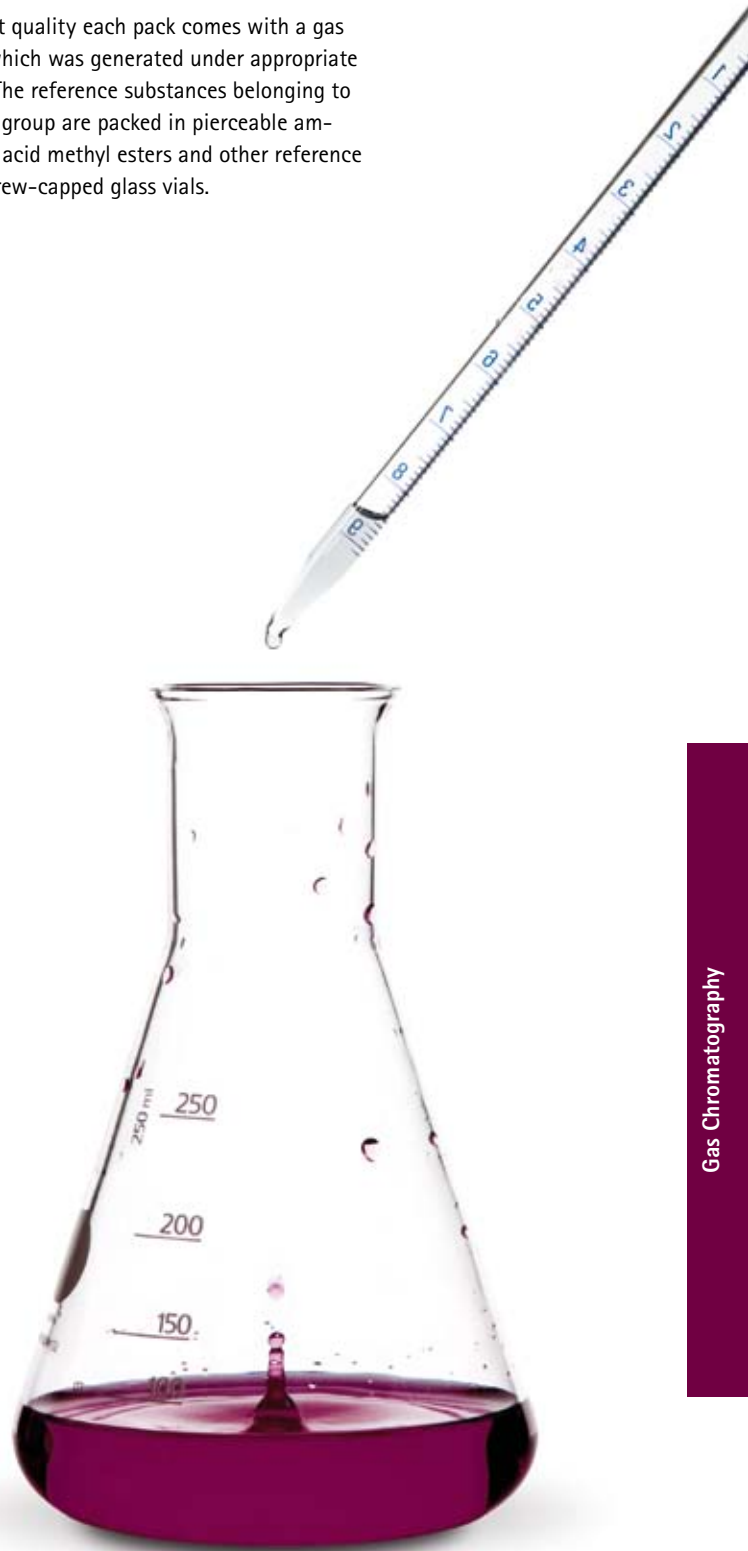

Ordering information – Hydrocarbons C5

Product	Ordering No.	Assay [%]	Empirical formula	Content / Packaging
Cyclopentane	1.09662.0005	≥ 99.5	C ₅ H ₁₀	5 mL GA
2-Methylbutane	1.09643.0005	≥ 99.7	C ₅ H ₁₂	5 mL GA
n-Pentane	1.09719.0005	≥ 99.7	C ₅ H ₁₂	5 mL GA

GA = glass ampoule

Ordering information – Hydrocarbons C6

Product	Ordering No.	Assay [%]	Empirical formula	Content / Packaging
Benzene	1.09646.0005	≥ 99.9	C ₆ H ₆	5 mL GA
Cyclohexane	1.09663.0005	≥ 99.7	C ₆ H ₁₂	5 mL GA
n-Hexane	1.09687.0005	≥ 99.7	C ₆ H ₁₄	5 mL GA

GA = glass ampoule

Ordering information – Hydrocarbons C7

Product	Ordering No.	Assay [%]	Empirical formula	Content / Packaging
n-Heptane	1.09686.0005	≥ 99.5	C ₇ H ₁₆	5 mL GA
3-Methylhexane	1.09703.0005	≥ 99.0	C ₇ H ₁₆	5 mL GA
Toluene	1.09768.0005	≥ 99.7	C ₇ H ₈	5 mL GA

GA = glass ampoule

Ordering information – Hydrocarbons C8

Product	Ordering No.	Assay [%]	Empirical formula	Content / Packaging
3-Methylheptane	1.09699.0005	≥ 99.0	C ₈ H ₁₈	5 mL GA
n-Octane	1.09716.0005	≥ 99.0	C ₈ H ₁₈	5 mL GA
o-Xylene	1.09798.0005	≥ 99.0	C ₈ H ₁₀	5 mL GA
m-Xylene	1.09797.0005	≥ 99.3	C ₈ H ₁₀	5 mL GA
p-Xylene	1.09799.0005	≥ 99.5	C ₈ H ₁₀	5 mL GA

GA = glass ampoule

Ordering information – Hydrocarbons C9 – C19

Product	Ordering No.	Assay [%]	Empirical formula	Content / Packaging
n-Decane	1.09603.0005	≥ 99.5	C ₁₀ H ₂₂	5 mL GA
n-Dodecane	1.09658.0005	≥ 99.0	C ₁₂ H ₂₆	5 mL GA
n-Heptadecane	1.09604.0005	≥ 99.3	C ₁₇ H ₃₆	5 mL GA
n-Hexadecane	1.09605.0005	≥ 99.0	C ₁₆ H ₃₄	5 mL GA
n-Nonane	1.06833.0005	≥ 99.5	C ₉ H ₂₀	5 mL GA
n-Octadecane	1.09606.0005	≥ 99.3	C ₁₈ H ₃₈	5 mL GA
n-Pentadecane	1.09607.0005	≥ 99.5	C ₁₅ H ₃₂	5 mL GA
n-Tetradecane	1.09608.0005	≥ 99.0	C ₁₄ H ₃₀	5 mL GA
n-Tridecane	1.09609.0005	≥ 99.5	C ₁₃ H ₂₈	5 mL GA
n-Undecane	1.09794.0005	≥ 99.5	C ₁₁ H ₂₄	5 mL GA

GA = glass ampoule

Ordering information – Fatty acid methyl esters

Product	Ordering No.	Assay [%]	Empirical formula	Content / Packaging
Methyl decanoate	1.09637.0005	≥ 99.5	C ₁₁ H ₂₂ O ₂	5 mL GV
Methyl laurate	1.09693.0005	≥ 99.0	C ₁₃ H ₂₆ O ₂	5 mL GV
Methyl linoleate	1.09767.0005	≥ 99.0	C ₁₉ H ₃₄ O ₂	5 mL GV
Methyl margarate	1.09754.0005	≥ 99.0	C ₁₈ H ₃₆ O ₂	5 mL GV
Methyl myristate	1.09736.0005	≥ 99.5	C ₁₅ H ₃₀ O ₂	5 mL GV
Methyl octanoate	1.09633.0005	≥ 99.5	C ₉ H ₁₈ O ₂	5 mL GV
Methyl oleate	1.09743.0005	≥ 99.0	C ₁₉ H ₃₆ O ₂	5 mL GV
Methyl stearate	1.09602.0005	≥ 99.0	C ₁₉ H ₃₈ O ₂	5 g GV

GV = glass vial

Ordering information – Miscellaneous reference substance

Product	Ordering No.	Assay [%]	Empirical formula	Content / Packaging
D-Camphor	1.09656.0005	≥ 99.0	C ₁₀ H ₁₆ O	5 g GV
Cyclohexanol	1.09667.0005	≥ 99.0	C ₆ H ₁₂ O	5 mL GV
Cyclohexanone	1.09664.0005	≥ 99.8	C ₆ H ₁₀ O	5 mL GV
Ethyl methyl ketone	1.09709.0005	≥ 99.5	C ₄ H ₈ O	5 mL GV
Hexamethyldisiloxane	1.04500.0100	≥ 99.0	C ₆ H ₁₈ OSi ₂	100 mL GV

GV = glass vial

08

Indices & Contacts

Subject index page 389

Index of ordering numbers page 392

Merck Millipore around the world page 398

Analytical Application Finder and more education material page 405



Subject index

A	
	Page
Accessories for TLC	123
Accessories for particulate HPLC columns	296, 299, 301
Acetone	17, 374
Acetonitrile	17, 21, 22, 24
Acetonitrile gradient grade	17, 18
Acetyl salicylic acid	254
Active charcoal	382
Acylation	384
ADS = Alkyl-DIOL-Silica	58
Alkaline stable HPLC separations	275
Alkaloids	152, 267
Alumina particles	275
Aluminium oxide	120, 122
Aluminium oxide for preparative chromatography	334
Aluminium oxide TLC plates	97, 122
Aluminium backed	95, 100, 104, 107, 109
Aluspher® RP-select B	276
Amberjet®	70
Amberlite®	68, 70, 71
Amberlyst®	68, 70
Amines from Azo Dyes	241
Amino shielding	242
Aminopropyl	192, 238, 269
Amount of alkyl chains	214
Amphetamine compounds	276
Angiotensin I and II	257
Anisols	239
Antiepileptic drugs (AEDs) in serum	48
Application of LiChrolut® EN	54
Aqueous mobile phase	144, 219, 226
Aqueous sample	44, 45, 46
Automated multiple development (AMD)	100
Avicel®	343
B	
	Page
Baseline (Trouble-Shooting)	327
Benzene	17, 386
Beta-Blockers	230, 241, 277
Beta-cyclodextrin	288, 290
Bimodal porous silica rod	200
C	
	Page
C2 modification	104
C8 modification (HPLC and TLC)	104, 154, 156, 159, 161, 166, 188, 236, 246, 250, 261, 264
C9 – C19	387
C18 modification (HPLC and TLC)	104, 154, 156, 159, 161, 166, 172, 200, 204, 212, 219, 232, 234, 240, 242, 244, 246, 250, 252, 256, 258
C18 endcapped packed reversed-phase columns	172
Capacity	44, 45, 46, 47, 52, 53, 58, 68, 206, 248, 251
Carbidopa	178, 230
Carbohydrates	239
CARS	363
Cartridge system	296, 299, 308
Catecholamines	229
Cellulose packing materials	343
Cellulose TLC and HPTLC	109
Certified reproducibility	251
Characterization of Purospher®	214, 222
Chelex®	69
ChiraDex®	288, 290
Chiral HPLC columns	290
Chiral separation	288, 290
Chiral stationary phases	288
Chloroform, stabilized	17, 374
Chromolith® CapRod®	161
Chromolith® column coupler	198
Chromolith® Flash	175, 176, 192
Chromolith® guard cartridges and cartridge kits	195
Chromolith® HPLC columns	160, 166
Chromolith® HighResolution columns	172
Chromolith® NH ₂	192
Chromolith® Prep	204, 345
Chromolith® RP-18 endcapped	172
Chromolith® RP-8 endcapped	188
Chromolith® SemiPrep	200
Chromolith® Si	190
Chromolith® SpeedROD	175, 176, 192
Chromolith® Performance	175, 176, 190, 192
Classical silica TLC plates (TLC)	94
Classical TLC	93
CN-modified silica gel HPLC columns	250, 268
CN-, Diol- and NH ₂ -modified plates (TLC and HPTLC)	83
Column accessories	195, 198, 205, 296, 299, 301
Column care and use	308
Column coupling	167, 172, 188, 190, 198
Column dimension	158
Column equilibration	309
Column hardware	308
Column installation	309
Column length (Preparative HPLC)	353
Column lifetime	310
Column performance	309
Column regeneration	313
Column selection guide	152
Column storage	312
Column void time	314
Concentrating zone plates (TLC, HPTLC, PLC)	112
Corticoids	254
Cost savings	171
Customized packings	292
Customized pre-packed columns	347
Cyanopropyl	250
Cyclohexane	18, 374, 386
D	
	Page
Detector selection (HPLC)	139
Derivatization reagents (GC)	383
Dichloromethane	18, 374, 378
DIOL-modified silica gel HPLC columns	250, 251, 270
Dowex®	68, 70
Down-scaling	349
Durapore®	73, 74, 75, 77, 80, 81
E	
	Page
Elix® Advantage System	31, 34
Enantiomer	288, 290
Enantioseparation	288
Endfittings	296, 299
Energy drinks	228
Engelhardt test	214, 216
Equilibration (Trouble-Shooting)	319
Ethanol gradient grade	18, 20
Ethyl vinyl benzene divinyl benzene polymer	53
Ethyl acetate	18, 24
Exclusion chromatography	270
Explosives	244, 255
EXTrelut®	43
EXTrelut® NT	44
EXTrelut® NT accessories	47
EXTrelut® NT refill packs and bulk materials	46
EXTrelut® NT working principle	44
EXTrelut® NT1, EXTrelut® NT3 and EXTrelut® NT20	45
EXTrelut® sorbents	43
F	
	Page
Fatty acid methyl esters	385
Flavonoids	153, 228
Florisil® packing materials	344

Subject index

Florisil®	50, 52, 344
Flow gradients	172, 188, 190
Flow programming	169
Fluorescent indicators	99
Fluoropore™	73, 74, 75, 77
Fraction range of LiChrospher®	251
Fungicides in wine	267

G Page

Gas Chromatography	368
Glass cartridges EcoCART®	248, 252, 265, 294
Glass backed	95, 100, 104, 107, 109, 113, 119, 120
GLP plates (TLC and HPTLC)	119
Gradient grade	17, 18, 19, 20

H Page

Hexagon	212, 219
Hibar® columns	301, 308, 309, 341
Hibar® customized pre-packed columns	347
Hibar® pre-packed columns	346
High flow rates	161, 170, 172, 188, 190
High performance silica plates (HPTLC)	99
High porosity synthetic silica gel particles	50
High purity solvents	15, 16, 372
High purity solvents for gas chromatography	372
High separation efficiency	147, 166, 170, 219, 238
High throughput	102, 161, 172, 188, 190, 359
Higher sample throughput	167
Highly porous monolithic rods	160, 163, 166, 192
Highly pure stationary phases (Type B)	154
High-purity	109, 143, 156, 160, 188, 192, 200, 212
High-purity polymeric silica gel	166
High-purity silica	172, 190, 238, 240, 242, 244
High-purity silica gel	238
High-purity spherical silica	156, 278
Hormones	231
HPTLC	93, 99, 102, 104, 107, 109, 112, 115, 118, 119
Hydrocarbons	386, 387
Hydrophilic analytes	64, 142, 308
Hydrophobic analytes	64
Hydrophobicity	214
Hydroxyl	51, 142, 250, 334, 338
Hypergrade	15, 16, 21

I Page

Important EXTrelut® NT extraction parameters	48
Inclusion type phases	288
Injection volume (Preparative HPLC)	350
Instrumental influence (Preparative HPLC)	355
Ion chromatography	360
Ion exchange capacity	214, 225

Ion exchange chromatography	269
Ion exchanger	68, 69, 70, 71
Ion exchangers for sample preparation	66
Irregular	53, 309
Irregular particles	272, 334, 336, 338, 342
Isocratic grade	17, 19
Isohexane	18, 374
Isooctane	18, 374

K Page

Kieselguhr and mixed layer plates	98
-----------------------------------	----

L Page

Lab Water Purification	31
LC-integrated	43
Leaks (Trouble-Shooting)	326
LiChroCART®	220, 235, 246, 250, 272, 292, 296, 299, 308
LiChrolut®	50, 52
LiChrolut® EN	53
LiChrolut® extraction unit and drying attachment	56
LiChrolut® RP-18	52, 54
LiChrolut® selection guide	51
LiChrolut® sorbents	43, 52
LiChroprep®	366
LiChropur® reagents for analytical HPLC	43
LiChrosolv®	15, 16, 21
LiChrosolv® gradient grade products	20
LiChrosolv® hypergrade	15, 21
LiChrosorb®	272
LiChrospher®	250, 341
LiChrospher® ADS	42, 58
LiChrospher® DIOL	250, 270
LiChrospher® HPTLC	102
LiChrospher® NH ₂	250, 269
LiChrospher® PAH	250, 258
LiChrospher® RP-select B	264
LiChrospher® Si 60 and Si 100	271
LiChrospher® WP 300 RP-18	256
LiChrospher® 100 CN	268
LiChrospher® 100 DIOL	270
LiChrospher® 100 NH ₂	269
LiChrospher® 100 RP-18	252, 341, 346
LiChrospher® 100 RP-18 and RP-18 endcapped	252
LiChrospher® 100 RP-18 endcapped	252, 341, 346
LiChrospher® 100 RP-8	261, 346
LiChrospher® 100 RP-8 and RP-8 endcapped	261, 346
LiChrospher® 100 RP-8 endcapped	261
LiChrospher® 60 RP-select B	264
LiChrospher® CN	250
LiChrospher® Si	250, 271
LiChroTest®	306
Liquid stationary phases	382
Liquid-liquid extraction	42, 44, 45
log P value	152

Loose sorbents for preparation of TLC plates	121
Low ppb trace range	21
LuxPlate®	95

M Page

Magnesia-loaded silica gel	50
manu-CART®	296
Mass overload (Preparative HPLC)	352
Merck Millipore around the world	398
Methanol gradient grade	19
Methanol hypergrade	19
Method development (HPLC)	136
Method validation (HPLC)	150
Micro-particulate sorbents	161
Milllex®	72, 73, 76, 80
Milllex Simplicity™	85, 89
Millipore-Express	73, 75, 77
Milli-Q® Advantage System	31, 35
Milli-Q® Integral System	31, 36
Millivac®	77
Mobile Phases & Reagents for HPLC and TLC	15
Mobile phase selection (HPLC)	144, 310
Monolithic	160, 161, 166, 172, 192, 204
Monolithic silica	156, 160, 161, 188, 190, 195, 200
Monolithic silica gel	160, 161
Multiformat plates (TLC and HPTLC)	118

N Page

Naphthols, chlorophenol and nitro-aromatics in water	255
NH ₂ -modified silica gel HPLC columns	192, 238, 250, 269
n-Heptane	18, 386
n-Hexane	18, 24, 374, 378, 386
Non-modified silica gel HPLC columns (Si)	190, 204, 238, 250, 251, 271, 273
Normal phase HPLC	142, 154, 308
Nucleosil®	294
Nucleotides	263

O Page

Octadecyl	156, 195, 246, 250, 272, 338, 341
Octyl	156, 246, 250, 272, 338
Omnipore®	77
Operational Qualification (OQ)	307
Overall chromatographic properties	214

P Page

Packing stand	210
PAH	21, 104, 112, 153, 250, 258, 372
PAH trace analysis	258
Particulate HPLC columns and sorbents	212, 246, 250, 272, 275, 278, 288, 292

Peak symmetry	168, 172, 212, 219, 236, 240, 320
Peaks (Trouble-Shooting)	320
PEI Cellulose	111
Peptides	111, 115, 153, 231, 250, 256
Performance Qualification (PQ)	306
Pharmaceutical analysis	150, 254
Pharmacopeia	100, 127, 150, 306, 376
Phenols	153, 266
pH stability (HPLC)	311
Plastic backed	94, 109, 111
PLC	112, 120, 121
Polybutadiene (PBD)	275
Polycyclic aromatic hydrocarbons (PAH)	21, 104, 112, 258, 372
Poly-L-lysine peptides	257
Pre-coated plates	93, 121, 127
Precolumns	64, 296, 299, 301
Preparative chromatography	24, 309, 334, 342
Preparative HPLC	204, 330, 355, 359
Preparative layer plates (PLC)	120
Preparative Liquid Chromatography	309, 341
Prepsolv®	15, 24
Pressure stability	310
Pressure (Trouble-Shooting)	328
ProteoChrom® HPTLC plates for peptide analysis	115
Proteomics	137, 161, 187
Purospher®	212
Purospher® RP-18	242
Purospher® RP-18 endcapped	240
Purospher® RP-18 HC	244
Purospher® STAR	212, 219, 232, 234, 236, 238
Purospher® STAR NH ₂	238
Purospher® STAR RP-18 endcapped	219
Purospher® STAR RP-8 endcapped	236
Purospher® STAR Si	238
Purospher® STAR Si (Silica) and NH ₂ (Amino-phase)	238
Purospher® STAR UHPLC columns	234

R Page

Reagents for HPLC and TLC	15
Recovery (Trouble-Shooting)	325
Reference substances (GC)	385
Restricted access materials (RAM)	58
Retention (Trouble-Shooting)	317
Reversed phase chromatography	172, 188, 192, 269
RP-modified silica plates (TLC and HPTLC)	104
RP-modified silica gel	102, 104, 115, 120
RP-2 (TLC)	104
RP-8 (TLC)	104
RP-18 (TLC)	104

S Page

Sample filtration	72, 73, 76, 80, 82, 85, 88
Sample preparation	38, 42, 138
Samplcity™	82, 85, 88

SAMS	363
Scaling the separation	348
Select B	264, 275
Selection guide	51, 152
Selectivity optimization (HPLC)	146
Selectivity (Trouble-Shooting)	326
Semi-preparative columns	158, 283, 308
Semi-preparative HPLC	355
Separation efficiency (Preparative HPLC)	351
Separation of basic compounds	246, 250, 256
Separation of enantiomers	288, 290
Separation of polar and hydrophilic compounds	278
Separation performance	251
Separation under aqueous conditions	242
SeQuant® SAMS & CARS suppressor system	363
SeQuant® ZIC®-HILIC	278, 282
SeQuant® ZIC®-pHILIC	287
Silanol capacity	214, 225
Silica carrier	246
Silica columns	160, 308, 371
Silica gels for preparative HPLC	336
Silylation	384
Stable reversed phase stationary phase	276
Solid-phase extraction	42, 50, 52, 53
Solvent Management System	25
Solvents for gas chromatography	372, 373
Solvents for HPLC	12
Sorbents	43, 52, 61, 121, 161, 214, 248, 253, 261, 265, 268, 269, 270, 271, 273, 295, 309, 342, 347, 382
Sorbents for packed columns (GC)	382
Specification of column sorbents	156
Speed of analysis	160, 166
Stahl	124
Stainless steel cartridges LiChroCART®	220, 237, 238, 240, 242, 244, 249, 253, 256, 262, 265, 268, 269, 270, 271, 274, 276, 291, 293, 294, 297, 299
Stainless steel columns Hibar®	237, 252, 262, 265, 271, 274, 294
Standardized silica gels	336
Stationary phase selection (HPLC)	141, 154, 156
Steric selectivity	214
Steroids	153, 178, 199
Stericup®	77
Steritop®	77
Sulfonamides	153
Superspher®	246
Suppressor system	363
SupraSolv® solvents for gas chromatography	373
Sweeteners	153, 231
System optimization	147

T Page

Tailor-made solvents	372
Tanaka test	215, 225
Technical appendix	124
Temperature stability (HPLC)	311
tert-Butyl methyl ether	17, 374

Tetrahydrofuran	19
Thin layer chromatography (TLC)	90
TLC plates (silica)	94
Toluene	19, 102, 375, 378, 386
Toluidines	243
Triptylines	228
tRNA molecules	256
Trouble-Shooting (HPLC)	316

U Page

UHPLC columns	173, 234
Ultra-fast separation	176, 185
Ultrapure water	31
UniSolv®	372, 378
UniSolv® solvents for organic trace analysis	378
Up-scaling	348, 355
USP column classification (HPLC)	156, 159

V Page

Volume overload (Preparative HPLC)	351
------------------------------------	-----

W Page

Water	19, 20, 21, 22
Water purification	31
Wide-pore kieselguhr	44

Z Page

ZIC®-HILIC	278, 282
ZIC®-pHILIC	287

Numerics Page

1-Butanol	17
1-Chlorobutane	17
1,2-Dichloroethane	18
1,4-Dioxane	18
1-Propanol	19
2-Oxoacids	254
2-Propanol	19, 20, 24, 375

Index of ordering numbers

Ordering No.	Page	Ordering No.	Page	Ordering No.	Page	Ordering No.	Page	Ordering No.	Page
1.00...		1.01040.4000	19	1.02...		1.04369.2500	378	1.05552.0001	109
1.00012.1000	374	1.01040.5000	19	1.02014.0001	52	1.04369.9010	378	1.05553.0001	95
1.00012.2500	374	1.01040.9010	19	1.02016.0001	52	1.04371.1000	374	1.05554.0001	95
1.00012.4000	374	1.01040.9030	19	1.02021.0001	52	1.04371.2500	374	1.05556.0001	100
1.00012.9030	374	1.01040.9185	19	1.02022.0001	52	1.04371.4000	374	1.05559.0001	104
1.00017.1000	374	1.01061.1000	335	1.02023.0001	52	1.04371.9010	374	1.05560.0001	104
1.00017.2500	374	1.01061.2000	335	1.02024.0001	52	1.04371.9030	374	1.05562.0001	95
1.00017.4000	374	1.01067.1000	335	1.02035.0100	123	1.04390.1000	18	1.05563.0001	109
1.00020.1000	17	1.01067.2000	335	1.02122.0001	52	1.04390.2500	18	1.05564.0001	119
1.00020.2500	17	1.01076.1000	335	1.02129.0001	167, 175	1.04390.9010	18	1.05565.0001	109
1.00020.4000	17	1.01076.2000	335	1.02206.0001	56	1.04390.9030	18	1.05566.0001	119
1.00020.5000	17	1.01076.9020	335	1.02330.0500	122	1.04390.9185	18	1.05567.0001	98
1.00020.9010	17	1.01077.1000	335	1.02331.0500	343	1.04391.1000	18	1.05568.0001	98
1.00020.9050	17	1.01077.2000	335	1.02331.2500	343	1.04391.2500	18	1.05570.0001	95
1.00029.1000	17, 22	1.01077.9020	335	1.02331.9025	343	1.04391.4000	18	1.05574.0001	109
1.00029.2500	17, 22	1.01078.1000	335	1.02333.0100	384	1.04391.5000	18	1.05577.0001	109
1.00029.9010	17, 22	1.01078.2000	335	1.02333.0250	384	1.04391.9010	18	1.05579.0001	111
1.00029.9030	17, 22	1.01078.9020	335	1.02432.1000	374	1.04391.9030	18	1.05581.0001	97
1.00030.1000	17	1.01090.2500	122	1.02432.2500	374	1.04391.9185	18	1.05582.0001	112
1.00030.2500	17	1.01090.9025	122	1.02444.1000	17	1.04394.9030	24	1.05583.0001	112
1.00030.4000	17	1.01092.0500	122	1.02444.2500	17	1.04500.0100	384, 387	1.05586.0001	103
1.00030.5000	17	1.01097.1000	335	1.02444.4000	17	1.04717.1000	18	1.05608.0001	118
1.00030.9010	17	1.01097.5000	335	1.02444.9010	17	1.04717.2500	18	1.05613.0001	119
1.00030.9030	17	1.01097.9050	335	1.02817.1000	374	1.04765.0500	68	1.05616.0001	100
1.00030.9185	17	1.01123.0001	28	1.02817.2500	374	1.04765.5000	68	1.05620.0001	118
1.00202.1000	376	1.01692.1000	17	1.02817.4000	374	1.04767.0500	70	1.05626.0001	95
1.00202.2500	376	1.01767.0500	69	1.02817.9010	374	1.04767.5000	70	1.05628.0001	100
1.00423.	294	1.01768.1000	17	1.02827.1000	18	1.04835.0500	69	1.05629.0001	100
1.00424.	294	1.01772.1000	375	1.02827.2500	18	1.04835.5000	69	1.05631.0001	100
1.00480.0100	123	1.01772.2500	375	1.02827.9030	18	1.04836.0500	71	1.05632.0001	109
1.00868.1000	18	1.01772.4000	375	1.03...		1.04836.5000	71	1.05633.0001	100
1.00868.2500	18	1.01772.9010	375	1.03132.1000	18	1.05...		1.05635.0001	118
1.00868.4000	18	1.01772.9030	375	1.03132.2500	18	1.05221.0250	68	1.05636.0001	107
1.00868.9010	18	1.01845.1000	17	1.03830.0001	27	1.05238.0250	68	1.05637.0001	120
1.00931.1000	374	1.01845.2500	17	1.03831.0001	27	1.05241.0500	68	1.05641.0001	100
1.00931.2500	374	1.01845.9010	17	1.03832.0001	27	1.05242.0250	70	1.05642.0001	100
1.00931.4000	374	1.01845.9030	17	1.03833.0001	27	1.05245.0500	70	1.05644.0001	100, 118
1.00998.1000	375	1.01845.9185	17	1.03834.0001	27	1.05434.0001	120	1.05646.0001	103
1.00998.2500	375	1.01988.1000	17	1.03835.0001	27	1.05533.0001	107	1.05647.0001	103
1.01...		1.01988.2500	17	1.03836.0001	27	1.05547.0001	100	1.05648.0001	100
1.01024.1000	19	1.01900.1000	376	1.04...		1.05548.0001	100	1.05650.0001	115
1.01024.2500	19	1.01900.2500	376	1.04335.2500	18	1.05549.0001	95	1.05651.0001	115
1.01040.1000	19	1.01995.1000	374	1.04340.2500	374	1.05550.0001	97	1.05655.0001	115
1.01040.2500	19	1.01995.2500	374	1.04369.1000	378	1.05551.0001	97	1.05702.0001	119

Index of ordering numbers

Ordering No.	Page	Ordering No.	Page	Ordering No.	Page	Ordering No.	Page	Ordering No.	Page
1.05713.0001	97	1.06035.1000	19, 22	1.08101.9010	19	1.09633.0005	387	1.10972.9030	374
1.05714.0001	95	1.06035.2500	19, 22	1.08101.9030	19	1.09637.0005	387	1.10983.1000	374
1.05715.0001	95	1.06035.9030	19, 22	1.08327.1000	19	1.09643.0005	386	1.10983.2500	374
1.05716.0001	109	1.06044.1000	18	1.08327.2500	19	1.09646.0005	386	1.11...	
1.05717.0001	120	1.06044.2500	18	1.08327.4000	19	1.09649.0010	384	1.11678.1000	121
1.05718.0001	109	1.06044.4000	18	1.08388.1000	378	1.09649.0025	384	1.11695.1000	121
1.05719.0001	95	1.06044.9010	18	1.08388.2500	378	1.09656.0005	387	1.11727.1000	18
1.05721.0001	95	1.06044.9030	18	1.08389.1000	375	1.09658.0005	387	1.11727.2500	18
1.05724.0001	95	1.06044.9185	18	1.08389.2500	375	1.09662.0005	386	1.11727.4000	18
1.05725.0001	111	1.06054.1000	374	1.08389.4000	375	1.09663.0005	386	1.11727.9030	18
1.05726.0001	120	1.06054.2500	374	1.08389.9010	375	1.09664.0005	387	1.11727.9185	18
1.05728.0001	109	1.06054.4000	374	1.08540.0001	123	1.09667.0005	387	1.11764.0001	100
1.05729.0001	95	1.06054.9010	374	1.08541.0001	123	1.09669.0100	382	1.11798.0001	112
1.05730.0001	109	1.06454.1000	378	1.08803.0001	28	1.09678.0100	382	1.11805.0005	384
1.05731.0001	97	1.06705.0100	123	1.09...		1.09686.0005	386	1.11844.0001	112
1.05735.0001	96	1.06710.0001	28	1.09303.0100	339	1.09687.0005	386	1.11845.0001	112
1.05738.0001	98	1.06833.0005	387	1.09303.0500	339	1.09693.0005	387	1.11846.0001	112
1.05744.0001	120	1.07...		1.09303.5000	339	1.09699.0005	386	1.12...	
1.05745.0001	120	1.07070.0001	28	1.09303.9025	339	1.09703.0005	386	1.12186.0025	384
1.05746.0001	104	1.07288.1000	378	1.09309.0010	273	1.09709.0005	387	1.12186.0100	384
1.05747.0001	104	1.07288.2500	378	1.09318.0010	273	1.09716.0005	386	1.12298.0101	382
1.05748.0001	96	1.07719.0250	342	1.09318.0100	273	1.09719.0005	386	1.12298.1001	382
1.05749.0001	96	1.07719.1000	342	1.09332.0010	273	1.09726.0100	382	1.12363.0001	100
1.05750.0001	96	1.07729.1000	337	1.09333.0010	273	1.09727.0100	382	1.12463.0500	70
1.05786.0001	110	1.07729.5000	337	1.09334.0010	273	1.09729.0100	382	1.12513.0010	384
1.05787.0001	110	1.07729.9025	337	1.09335.0010	273	1.09736.0005	387	1.12518.0100	342, 344
1.05788.0001	120	1.07730.1000	121	1.09335.0100	273	1.09743.0005	387	1.12518.1000	342, 344
1.05789.0001	95	1.07730.5000	121	1.09336.1000	339	1.09754.0005	387	1.12537.0001	123
1.05801.0001	95	1.07730.9025	121	1.09336.9025	339	1.09762.0100	382	1.12572.0001	107
1.05802.0001	95	1.07731.1000	121	1.09341.0010	273	1.09766.0100	382	1.12668.0001	107
1.05804.0001	95	1.07731.5000	121	1.09362.0250	339	1.09767.0005	387	1.12994.0100	342, 344
1.05805.0001	95	1.07731.9025	121	1.09362.1000	339	1.09768.0005	386	1.12994.1000	342, 344
1.05808.0001	95	1.07734.1000	337	1.09385.1000	337	1.09771.0005	384	1.13...	
1.05914.0001	105	1.07736.1000	121	1.09385.2500	337	1.09794.0005	387	1.13124.0001	105
1.06...		1.07736.2500	121	1.09385.5000	337	1.09797.0005	386	1.13171.0001	304
1.06007.1000	19	1.07736.9025	121	1.09385.9025	337	1.09798.0005	386	1.13187.0001	113
1.06007.2500	19	1.07739.1000	121	1.09387.0100	273	1.09799.0005	386	1.13192.0001	107
1.06007.4000	19	1.07739.2500	121	1.09389.5000	337	1.10...		1.13203.0001	123
1.06007.5000	19	1.07739.9025	121	1.09389.9025	337	1.10180.1000	337	1.13326.0001	119
1.06007.9010	19	1.07741.1000	121	1.09390.1000	339	1.10180.5000	337	1.13350.2500	24
1.06007.9030	19	1.07747.1000	121	1.09602.0005	387	1.10180.9025	337	1.13350.9910	24
1.06007.9185	19	1.07747.2500	121	1.09603.0005	387	1.10181.1000	337	1.13351.2500	24
1.06011.1000	374	1.07747.9025	121	1.09604.0005	387	1.10181.9025	337	1.13351.9030	24
1.06011.2500	374	1.07748.1000	121	1.09605.0005	387	1.10255.0005	384	1.13351.9185	24
1.06011.4000	374	1.07748.2500	121	1.09606.0005	387	1.10255.0025	384	1.13351.9910	24
1.06018.1000	19	1.07749.1000	121	1.09607.0005	387	1.10290.0001	123	1.13353.9030	24
1.06018.2500	19	1.07749.2500	121	1.09608.0005	387	1.10646.0001	123	1.13358.2500	24
1.06018.4000	19	1.07749.9025	121	1.09609.0005	387	1.10647.0001	123	1.13358.9030	24
1.06018.5000	19	1.08...		1.09624.0100	382	1.10972.1000	374	1.13358.9185	24
1.06018.9010	19	1.08101.1000	19	1.09624.0500	382	1.10972.2500	374	1.13358.9910	24
1.06018.9030	19	1.08101.2500	19	1.09631.0100	382	1.10972.4000	374	1.13713.1000	18
1.06018.9185	19	1.08101.4000	19	1.09631.0500	382	1.10972.9010	374	1.13724.0001	105

Index of ordering numbers

Ordering No.	Page	Ordering No.	Page	Ordering No.	Page	Ordering No.	Page	Ordering No.	Page
1.13725.0001	105	1.15131.5000	68	1.16178.0010	269	1.19640.0010	271	1.50017.0001	296, 297
1.13726.0001	105	1.15165.0500	71	1.16217.0001	301, 302	1.19640.0100	271	1.50018.0001	347
1.13727.0001	113	1.15201.0001	307	1.16225.0001	105	1.19641.0010	265	1.50031.0001	237
1.13728.0001	113	1.15256.0500	71	1.16333.0001	301, 303	1.19642.0010	265	1.50032.0001	237
1.13748.0001	113	1.15257.0500	71	1.16464.0001	107	1.19642.0100	265	1.50033.0001	237
1.13749.0001	113	1.15261.0500	70	1.16484.0001	95	1.19643.0010	248	1.50035.0001	237
1.13792.0001	113	1.15262.0500	70	1.16485.0001	95	1.19654.0100	341	1.50036.0001	221
1.13793.0001	113	1.15326.0001	95	1.16487.0001	95	1.19654.1000	341	1.50037.0001	221
1.13794.0001	113	1.15327.0001	95	1.16740.1000	378	1.19656.0100	341	1.50038.0001	237
1.13894.0001	120	1.15333.1000	19, 22	1.16740.2500	378	1.19656.0500	341	1.50082.0001	297, 298
1.13895.0001	120	1.15333.2500	19, 22	1.16834.0001	95	1.19676.0100	341	1.50083.0001	297, 298
1.13900.0250	339	1.15333.9010	19, 22	1.16835.0001	95	1.19686.0001	52	1.50092.0001	347
1.13900.1000	339	1.15333.9030	19, 22	1.16854.0001	249	1.19687.0001	52	1.50099.0001	347
1.13900.9025	339	1.15341.0001	95	1.16855.0001	249	1.19691.0001	52, 54	1.50117.0001	291
1.13901.0500	339	1.15373.0001	47	1.16857.0001	249	1.19693.0001	52, 54	1.50137.0001	256
1.13901.9010	339	1.15388.0001	104	1.16858.0001	249	1.19696.0001	52	1.50140.0001	256
1.13905.0250	339	1.15389.0001	104	1.16869.0001	249	1.19698.0001	52	1.50141.0001	242
1.13905.1000	339	1.15423.0001	104	1.18...		1.19699.0001	52	1.50142.0001	242
1.13905.9025	339	1.15424.0001	104	1.18303.0025	37	1.19753.0250	37	1.50144.0001	242
1.13959.0250	339	1.15440.1000	374	1.18304.0025	37	1.19754.0250	37	1.50148.0001	258
1.13973.0250	339	1.15440.2500	374	1.18305.0025	37	1.19767.0001	52	1.50149.0001	258
1.13974.0250	339	1.15445.0001	103	1.18306.0025	37	1.19847.0001	52	1.50154.0001	253
1.13974.1000	339	1.15498.0001	113	1.18307.0025	37	1.19849.0001	52	1.50155.0001	265
1.14...		1.15545.0001	305	1.18308.0025	37	1.19851.0001	56	1.50156.0001	258
1.14236.0001	47	1.15546.0001	305	1.18309.0025	37	1.19852.0001	56	1.50158.0001	265
1.14237.0001	47	1.15547.0001	305	1.18310.0025	37	1.19853.0020	54	1.50159.0001	253
1.14291.1000	17	1.15552.0001	100	1.18312.0025	37	1.19855.0001	52	1.50167.0001	240
1.14291.2500	17	1.15576.0001	299	1.18313.0025	37	1.19870.0001	52, 54	1.50168.0001	240
1.14291.4000	17	1.15622.0001	47	1.19...		1.19874.0001	56	1.50169.0001	240
1.14291.5000	17	1.15635.0500	68	1.19127.0001	52	1.19891.0001	56	1.50170.	293
1.14291.9010	17	1.15647.0001	107	1.19129.0001	52	1.19902.0001	56	1.50171.	293
1.14291.9030	17	1.15683.0001	104	1.19156.0001	307	1.19912.0001	52, 54	1.50171.7220	237
1.14291.9185	17	1.15684.0001	104	1.19157.0001	307	1.19941.0001	52	1.50172.	293
1.14296.0001	105	1.15685.0001	104	1.19158.0001	307	1.20...		1.50173.	293
1.14567.0001	47	1.15696.0001	100	1.19159.0001	307	1.20080.0001	26	1.50174.	293
1.15...		1.15959.0500	70	1.19161.0001	307	1.25...		1.50175.	293
1.15035.0001	110	1.15965.0500	71	1.19162.0001	307	1.25251.0001	167, 205	1.50177.	293
1.15036.0001	110	1.15966.0500	68	1.19163.0001	307	1.25252.0001	167, 205	1.50178.	293
1.15037.0001	113	1.16...		1.19165.0001	307	1.25254.0001	205	1.50179.	293
1.15092.1000	46	1.16009.0001	249	1.19169.0001	307	1.25255.0001	205	1.50180.	294
1.15093.0001	46	1.16010.0001	249	1.19609.0010	248	1.25256.0001	205	1.50181.	294
1.15094.0001	45	1.16039.0001	249	1.19612.0010	248	1.25257.0001	205	1.50182.	294
1.15095.0001	45	1.16051.0001	249	1.19613.0010	248	1.25258.0001	205	1.50183.	294
1.15096.0001	45	1.16052.0001	249	1.19617.0010	248	1.25259.0001	205	1.50187.0001	60
1.15101.1000	337	1.16054.0001	249	1.19618.0010	248	1.25260.0001	167, 205	1.50190.	293
1.15101.9025	337	1.16056.0001	249	1.19629.0010	271	1.25261.0001	167, 205	1.50193.0001	249
1.15111.1000	337	1.16092.0001	110	1.19631.0010	268	1.50...		1.50195.	293
1.15111.2500	337	1.16105.0010	253	1.19632.0010	261	1.50004.0001	347	1.50197.0001	249
1.15111.9025	337	1.16129.0010	261	1.19633.0010	253	1.50009.	294	1.50198.0001	249
1.15127.0500	71	1.16139.0010	261	1.19636.0010	261	1.50012.	294	1.50200.0001	249
1.15127.5000	71	1.16152.0010	270	1.19637.0010	253	1.50013.	294	1.50201.	293
1.15131.0500	68	1.16177.0010	253	1.19638.0010	268	1.50016.0001	347	1.50204.0001	249

Index of ordering numbers

Ordering No.	Page	Ordering No.	Page	Ordering No.	Page	Ordering No.	Page	Ordering No.	Page
1.50205.0001	249	1.50318.0001	274	1.50440.0001	282	1.50548.0001	252	1.50645.0001	234
1.50206.0001	60	1.50323.0001	347	1.50441.0001	282	1.50549.0001	252	1.50646.0001	234
1.50207.0001	60	1.50329.0001	262	1.50442.0001	282	1.50550.0001	252	1.50648.0001	234
1.50208.0001	60	1.50332.0001	274	1.50443.0001	282	1.50573.0001	265	1.50649.0001	234
1.50209.0001	60	1.50333.0001	274	1.50444.0001	282	1.50574.0001	265	1.50650.0001	234
1.50210.0001	61	1.50334.0001	274	1.50445.0001	282	1.50575.0001	265	1.50651.0001	234
1.50225.0001	220	1.50347.0010	61	1.50446.0001	282	1.50578.0001	262	1.50653.0001	234
1.50226.0001		1.50348.0010	61	1.50447.0001	282	1.50579.0001	262	1.50654.0001	234
220, 237, 293, 296, 297		1.50349.0010	61	1.50448.0001	282	1.50580.0001	262	1.50655.0001	234
1.50227.0001		1.50356.0001	238	1.50449.0001	282	1.50581.0001	262	1.50734.0001	253
220, 237, 293, 296, 297		1.50357.0001	238	1.50450.0001	282	1.50582.0001	262	1.50742.0001	265
1.50228.	293	1.50358.0001	220	1.50451.0001	282	1.50583.0001	262	1.50791.0001	249
1.50228.7220	237	1.50359.0001	220	1.50452.0001	282	1.50593.0001	221	1.50792.0001	249
1.50229.	293	1.50377.0001	252	1.50453.0001	282	1.50595.0001	221	1.50798.0001	240
1.50229.7220	237	1.50380.0001	60	1.50454.0001	282	1.50596.0001	221	1.50799.0001	240
1.50231.0001	220	1.50381.0001	60	1.50455.0001	282	1.50597.0001	221	1.50820.0001	271
1.50233.	293	1.50382.0001	60	1.50456.0001	283	1.50598.0001	221	1.50822.0001	262
1.50234.	293	1.50385.0001	60	1.50457.0001	282	1.50600.0001	253	1.50823.0001	253
1.50234.7220	237	1.50386.0001	60	1.50458.0001	282	1.50601.0001	253	1.50824.0001	269
1.50236.	293	1.50388.0001	274	1.50459.0001	287	1.50602.0001	253	1.50825.0001	268
1.50237.0001	220	1.50393.0001	221	1.50460.0001	287	1.50603.0001	253	1.50826.0001	270
1.50238.0001	220	1.50398.0001	221	1.50461.0001	287	1.50604.0001	253	1.50827.0001	262
1.50239.0001	220	1.50400.0001	162	1.50462.0001	287	1.50605.0001	253	1.50828.0001	253
1.50240.0001	220	1.50402.0001	162	1.50463.0001	287	1.50607.0001	221	1.50829.0001	265
1.50241.0001	220	1.50403.0001	162	1.50464.0001	287	1.50609.0001	364, 390	1.50830.0001	271
1.50242.0001	220	1.50404.0001	162	1.50465.0001	283	1.50610.0001	364, 390	1.50832.0001	262
1.50244.0001	238	1.50405.0001	162	1.50466.0001	283	1.50611.0001	364, 390	1.50833.0001	253
1.50245.0001	238	1.50407.0001	162	1.50468.0001	221	1.50612.0001	221	1.50834.0001	269
1.50247.0001	238	1.50409.0001	162	1.50469.0001	221	1.50613.0001	364, 390	1.50836.0001	270
1.50248.0001	238	1.50413.0001	221	1.50470.0001	221	1.50614.0001	364, 390	1.50837.0001	262
1.50249.0001	238	1.50414.0001	221	1.50471.0001	221	1.50615.0001	221	1.50838.0001	253
1.50250.0001	220	1.50415.0001	162	1.50477.0001	252	1.50616.0100	364, 390	1.50839.0001	265
1.50251.0001	220	1.50417.	294	1.50478.0001	283	1.50617.0001	221	1.50840.0001	271
1.50252.0001	220	1.50418.	294	1.50479.0001	283	1.50618.0001	364, 390	1.50842.0001	262
1.50253.0001	220	1.50419.	294	1.50480.0001	283	1.50619.0001	364, 390	1.50843.0001	253
1.50254.0001	220	1.50420.	294	1.50481.0001	283	1.50620.0001	221	1.50844.0001	269
1.50255.0001	220	1.50421.	294	1.50482.0001	283	1.50621.0001	221	1.50845.0001	268
1.50256.0001	220	1.50422.	294	1.50483.0001	283	1.50622.0001	221	1.50847.0001	262
1.50257.0001	220	1.50423.	294	1.50484.0001	283	1.50623.0001	220	1.50848.0001	253
1.50267.0001	238	1.50424.0001	162	1.50487.0001	283	1.50624.0001	220	1.50850.0001	271
1.50268.0001	238	1.50426.0001	162	1.50489.0001	283	1.50625.0001	220	1.50853.0001	253
1.50269.0001	238	1.50427.0001	221	1.50490.0001	283	1.50626.0001	220	1.50858.0001	253
1.50270.0001	237	1.50428.0001	221	1.50491.0001	283	1.50627.0001	220	1.50892.0001	268
1.50271.0001	237	1.50431.0001	221	1.50492.0001	283	1.50634.0001	262	1.50928.0001	271
1.50272.0001	237	1.50432.0001	274	1.50493.0001	283	1.50635.0001	262	1.50930.0001	262
1.50273.0001	237	1.50433.0001	274	1.50494.0001	283	1.50636.0001	262	1.50931.0001	253
1.50274.0001	237	1.50434.0001	282	1.50495.0001	283	1.50637.0001	262	1.50932.0001	269
1.50275.0001	237	1.50435.0001	282	1.50496.0001	283	1.50638.0001	262	1.50936.0001	253
1.50276.0001	237	1.50436.0001	282	1.50497.0001	283	1.50639.0001	262	1.50937.0001	265
1.50302.	293	1.50437.0001	287	1.50545.0001	252	1.50640.0001	265	1.50942.0001	262
1.50302.7220	237	1.50438.0001	287	1.50546.0001	252	1.50641.0001	265	1.50943.0001	253
1.50316.0001	271	1.50439.0001	282	1.50547.0001	252	1.50642.0001	265	1.50945.0001	262

Index of ordering numbers

Ordering No.	Page	Ordering No.	Page	Ordering No.	Page	Ordering No.	Page	Ordering No.	Page
1.50947.0001	60	1.51299.0001	249	1.51484.0001	346	9.20078.0001	26	SLCR013NL	74, 79
1.50955.0001	271	1.51308.0001	249	1.51485.0001	346	9.67...		SLCR025NB	75
1.50956.0001	262	1.51311.0001	276	1.51486.0001		9.67100.1040	28	SLCR025NK	75
1.50957.0001	253	1.51315.0001	276	220, 237, 238, 240, 242, 244,		9.67100.1041	28	SLCR025NS	75, 79
1.50958.0001	269	1.51318.0001	276	249, 253, 256, 258, 262, 265,		9.67100.1185	28	SLCRBZ5NK	81
1.50959.0001	268	1.51324.0003	294	268, 269, 270, 273, 274, 276,		9.67100.9100	28	SLCRBZ5NZ	81
1.50960.0001	270	1.51329.0003	294	291, 293, 294, 296, 297, 298		FGL...		SLCRDZ5NK	81
1.50961.0001	262	1.51333.0001	291	1.51487.0001		FGLP04700	77	SLCRDZ5NZ	81
1.50962.0001	253	1.51343.0001	274	221, 237, 252, 262, 265,		GNW...		SLCRT13NL	74
1.50963.0001	265	1.51345.0001	274	271, 274, 294, 301, 302		GNWP04700	77	SLF...	
1.50973.0001	249	1.51349.0001	274	1.51496.0001	299	GPW...		SLFG025NB	75
1.50974.0001	249	1.51351.0001	274	1.52...		GPWP04700	77	SLFG025NK	75
1.50975.0001	249	1.51353.0001	274	1.52001.0001	167, 175	GPWP09050	77	SLFG025NS	75
1.50980.0001	249	1.51354.0001	274	1.52002.0001	167, 175	GVW...		SLFG025NS	79
1.50981.0001	265	1.51355.0001	274	1.52003.0001	167, 175	GVWP04700	77	SLFGR04NL	74
1.50982.0001	262	1.51356.0001	274	1.52004.0001	167, 196	GVWP09050	77	SLFGX13NK	74
1.50983.0001	253	1.51378.0003	294	1.52005.0001	167, 196	JGW...		SLFGX13NL	74, 79
1.50984.0001	265	1.51384.0001	240	1.52006.0001	167, 175	JGWP04700	77	SLFGX13NL	79
1.50986.0001	262	1.51388.0003	294	1.52007.0001	167, 175	JGWP09025	77	SLFGX13TL	74
1.50987.0001	253	1.51419.0001		1.52008.0001	167, 196	LAB...		SLFH025NB	75
1.50993.0001	265	220, 237, 253, 262, 271,		1.52009.0001	167, 196	LABCLOSE1	34	SLFH025NK	75
1.50995.0001	253	274, 293, 296, 297		1.52010.0001	196	LCP...		SLFH025NS	75
1.51...		1.51423.0001	248	1.52011.0001	196	LCPAK0001	35, 36	SLFHR04NL	74
1.51000.0001	291	1.51425.0001	248	1.52012.0001	196	MPG...		SLFHX13NK	74
1.51192.0001	61	1.51427.0001	252	1.52013.0001	196	MPGP04001	35, 36	SLFHX13NL	74
1.51193.0001	61	1.51431.	293	1.52014.0001	167, 175	POD...		SLFHX13TL	74
1.51194.0001	61	1.51432.	293	1.52015.0001	167, 201	PODCOVER01	34	SLG...	
1.51195.0001	299	1.51436.0001	244	1.52016.0001	167, 201	PRO...		SLGN033NB	75
1.51196.	294	1.51442.	293	1.52020.0001	167, 175	PROG0T0S2	36	SLGN033NK	75
1.51207.0001		1.51443.	293	1.52021.0001	167, 175	QGA...		SLGN033NS	75
248, 252, 294		1.51444.	293	1.52022.0001	167, 175	QGARDT1X1	35	SLGNDZ5NK	81
1.51210.0001	301	1.51445.	293	1.52024.0001	167, 196	QTU...		SLGNDZ5NZ	81
1.51211.0001	301	1.51448.	293	1.52025.0001	167, 196	QTUMOTEX1	35, 36	SLGNX13NK	74
1.51213.0001	304	1.51449.	293	1.52026.0001	167, 192	SAM...		SLGNX13NL	74
1.51214.0001	304	1.51450.0001	167, 175	1.52027.0001	167, 192	SAMPLCR01	89	SLGNX13TL	74
1.51216.0001	305	1.51451.0001	167, 196	1.52028.0001	167, 192	SAMPLCR04	89	SLGP033NB	75
1.51217.0001	305	1.51452.0001	167, 196	1.52029.0001	167, 196	SAMPLG001	89	SLGP033NK	75
1.51218.0001	305	1.51453.0001	237	1.52030.0001	167, 196	SAMPLG004	89	SLGP033NS	75
1.51220.0001	301	1.51454.0001	237	1.52031.0001	162	SAMPSYSBL	89	SLGV033NB	75
1.51230.0001	305	1.51455.0001	221	1.52035.0001	167, 201	SAMPSYSGR	89	SLGV033NK	75
1.51231.0001	305	1.51456.0001	221	1.52036.0001	167, 201	SAMSYSLID	89	SLGV033NS	75
1.51232.0001	252	1.51460.0001	220	1.52037.0001	201	SAMTUBING	89	SLGVR04NK	74
1.51233.0001	265	1.51463.0001	167, 175	4.80...		SAMVIALTR	89	SLGVR04NL	74
1.51236.0001	305	1.51465.0001	167, 190	4.80112.2500	22	SAMWASTTR	89	SLGVX13NK	74
1.51237.0001	305	1.51466.0001	175	4.80112.9030	22	SCG...		SLGVX13NL	74
1.51238.0001	305	1.51467.0001	182, 198	4.80159.2500	22	SCGPS05RE	77	SLGVX13TL	74
1.51245.0001	305	1.51468.0001	167, 188	4.80170.2500	22	SCGPU05RE	77	SLH...	
1.51247.0001	305	1.51470.0001	167, 196	4.80448.2500	22	SD1...		SLHN033NB	75
1.51252.0001	305	1.51471.0001	167, 196	4.80508.9030	22	SD1M001V00	77	SLHN033NK	75
1.51257.0001	297	1.51478.0001	346	4.80672.2500	22	SD1P014M04	77	SLHN033NS	75
1.51258.0001	297	1.51482.0001	346	4.80853.4004	22	SLC...		SLHNBZ5NK	81
1.51288.0001	249	1.51483.0001	346	9.20...		SLCR013NK	74	SLHNBZ5NZ	81

Ordering No.	Page	Ordering No.	Page
SLHNDZ5NK	81	WP6122050	77
SLHNDZ5NZ	81	WP6122050	89
SLHNX13NK	74	XF5...	
SLHNX13NL	74	XF5423050	77
SLHNX13TL	74	XX1...	
SLHP033NB	75	XX1009020	77
SLHP033NK	75	XX1504700	77
SLHP033NS	75	XX6...	
SLHV033NB	75	XX6200006P	77
SLHV033NK	75	Z00...	
SLHV033NS	75	Z00Q0V0WW	35
SLHVBZ5NK	81	ZFR...	
SLHVBZ5NZ	81	ZFRE00200	34
SLHVDZ5NK	81	ZFRE00350	34
SLHVDZ5NZ	81	ZFW...	
SLHVR04NK	74	ZFWATDET4	34, 35, 36
SLHVR04NL	74	ZMQ...	
SLHVX13NK	74	ZMQSFTS01	34, 35, 36
SLHVX13NL	74	ZMQSP0D01	35, 36
SLHVX13TL	74	ZRX...	
SLL...		ZRXQ003WW	36
SLLGC13NL	74	ZRXQ005WW	36
SLLGC25NS	75	ZRXQ010WW	36
SLLGDZ5NK	81	ZRXQ015WW	36
SLLGDZ5NZ	81	ZRXSP0D01	34, 36
SLLGH13NK	74	ZRXSUPCL1	34
SLLGH13NL	74	ZRXSUPEG1	34
SLLGH25NB	75, 79	ZRXSUPUV1	34
SLLGH25NK	75	ZRXV003WW	34
SLLGH25NS	75	ZRXV005WW	34
SLLGM25NS	79	ZRXV010WW	34
SLLGR04NL	74	ZRXV015WW	34
SLLHC13NL	74		
SLLHC25NS	75		
SLLHR04NK	74		
SLLHR04NL	74		
SLLS025NS	75		
SLP...			
SLPBDZ5NK	81		
SLPBDZ5NZ	81		
TAN...			
TANKASMIN	34, 36		
TANKPE030	34, 36		
TANKPE060	34, 36		
TANKPE100	34, 36		
WMB...			
WMBQPOD01	34, 35, 36		
WMBSMT002	34, 36		
WP6...			
WP6110060	89		
WP6111560	77		
WP6111560	89		

Merck Millipore around the world

Address information: January 2012

Merck Millipore is represented throughout the world by companies of the Merck group or by local partners.

ALGERIA

VWR International S.A.S.
"Le Périgares" – Bât. B
201, rue Carnot
94126 FONTENAY-SOUS-BOIS CEDEX
Phone +33 (0) 1 4514 8500
E-mail info@fr.vwr.com
Internet www.vwr.com

ARGENTINA

Merck Quimica Argentina S.A.I.C.
4890 Tronador Street
Panamericana Plaza Building – 5th floor
1430 BUENOS AIRES
Phone +54 (0) 11 4546 8100
Telefax +54 (0) 11 4546 8199
E-mail merck@merck.com.ar
Internet www.merck.com.ar

AUSTRALIA

Merck Pty. Ltd.
207 Colchester Road
KILSYTH, VICTORIA 3137
Phone +61 (0) 3 9728 7600
Telefax +61 (0) 3 9728 1351
E-mail merck@merck.com.au
Internet www.merck-chemicals.com.au

AUSTRIA

REAGENTS AND LABORATORY PRODUCTS

VWR International GmbH
Graumannsgasse 7
1150 WIEN
Phone +43 (0) 1 9700 20
Telefax +43 (0) 1 9700 2600
E-mail info@at.vwr.com
Internet www.vwr.com

CHEMICALS FOR PRODUCTION

Merck KGaA
Frankfurter Str. 250
64293 DARMSTADT
Phone +49 (0) 6151 72 6894
Telefax +49 (0) 6151 72 90984
E-mail katja.kolb@merck.de
Internet www.merck.de

BAHRAIN

Solyman Services (UK) Ltd.
Sharjah Airport International
Free Zone
P.O.Box 8611
SHARJAH, U.A.E.
Phone +971 6557 2266
Telefax +971 6557 2271
E-mail ssl.dxb.chem@solymanservices-me.com

BANGLADESH

G. A. Traders
48/1, Purana Paltan, 3rd floor
DHAKA-1000
Phone +880 (0) 2896 3502
Telefax +880 (0) 2896 3519
E-mail gat@bdmail.net

BELARUS

ChemTech
TechnoPark, Office 703-704
Leninskaya Str. 63
212030 MOGILEV/WHITE RUSSIA
Phone +357 2222 20822
Telefax +357 2222 20822
E-mail igorsilyin@hotmail.com

BELGIUM

REAGENTS AND LABORATORY PRODUCTS

VWR International BVBA
Researchpark Haasrode 2020
Geldenaaksebaan 464
3001 LEUVEN
Phone +32 (0) 16 385 011
Telefax +32 (0) 16 385 35
E-mail customerservice@be.vwr.com
Internet www.vwr.com

CHEMICALS FOR PRODUCTION

Merck nv/sa
Brusselsesteenweg 288
3090 OVERIJSE
Phone +32 (0) 2 6860 806
Telefax +32 (0) 2 6860 774
E-mail info@merck.be
Internet www.merck.be

BELIZE

Merck S.A.
12 ave. 0-33, zona 2 de Mixco
CIUDAD DE GUATEMALA
Phone +502 2410 2400
+502 2410 2300 [Chemicals]
Telefax +502 2434 2954
E-mail quimicos@merck.com.gt
Internet www.merck.com.gt

BOLIVIA

Corimex Ltda.
Calle Montevideo No. 130
Edif. Requima, entre Capitán Ravelo y Av. Arce.
LA PAZ
Phone +591 2 2440 330
Telefax +591 2 2440 230
E-mail astahmer@corimex.com
bcruz@corimex.com

BRAZIL

Merck S.A., São Paulo
Av. das Nacoes Unidas, 12.995-31
04578-000 ANDAR – SÃO PAULO – SP
Phone +55 (0) 11 3346 8500
Telefax +55 (0) 11 3346 8506
E-mail quimica@merck.com.br
Internet www.merck.com.br

COMMERCIAL OFFICE

Merck Millipore, São Paulo
Rua São Paulo, 30 – Alphaville Empresarial
06465-130 BARUERI – SÃO PAULO
Phone +55 (0) 11 4133 8700
Telefax +55 (0) 11 4191 2779
Email quimica@merck.com.br
Internet www.merck.com.br

WAREHOUSE

Merck Millipore, São Paulo
Rua Torre Eiffel, 100 – Cotia
06705-481 COTIA – SÃO PAULO
Phone +55 (0) 11 4616 5431
Telefax +55 (0) 11 4614 0109
Email quimica@merck.com

BULGARIA

MERCK Bulgaria EAD
 Blvd. Prof. Tsvetan Lazarov 83
 1582 SOFIA
 Phone +359 (0) 2 8075 111
 Telefax +359 (0) 2 8075 100
 E-mail merck@merck.bg
 Internet www.merck.bg

CANADA

EMD Millipore Corporation
 290 Concord Road
 BILLERICA, MA 01821
 Phone +1 800 222 0342
 +1 978 715 4321
 Telefax +1 800 776 0999
 Email Customer.CareDesk@merckgroup.com
 Internet www.emdmillipore.com

CHILE

Merck S.A.
 Francisco de Paula Taforo 1981
 Casilla 48-D
 SANTIAGO DE CHILE
 Phone +56 (0) 2 3400 199
 Telefax +56 (0) 2 3400 198 / -199
 E-mail mqch@merck.cl
 Internet www.merck.cl

CHINA

Merck Chemicals (Shanghai) Co., Ltd.
 3/F, Tower 2, Kingdee Building,
 No. 88 Chenhui Road,
 Zhangjiang Hi-Tech Park, Pu Dong
 SHANGHAI 201203
 Phone +86 (0) 21 2033 8288
 Telefax +86 (0) 21 6249 6124
 E-mail Reception@merck-china.com
 Internet www.merck-china.com

Merck Beijing Rep. Office
 Room 1604, Tower B, SOHO New Town
 No. 88 Jianguo Road, Chaoyang District
 BEIJING 100022
 Phone +86 (0) 10 8580 2406
 Telefax +86 (0) 10 8580 1294
 E-mail Reception@merck-china.com
 Internet www.merck-china.com

Merck Guangzhou Rep. Office
 Room 802, Yi An Plaza No. 33, Jian She 6th Road
 GUANGZHOU 510060
 Phone +86 (0) 20 8363 4531
 Telefax +86 (0) 20 8363 4347
 E-mail Reception@merck-china.com
 Internet www.merck-china.com

COLOMBIA

Merck S.A.
 Calle 10 No. 65 - 75
 BOGOTÁ D.C.
 Phone +57 (0) 1 425 4770
 Telefax +57 (0) 1 425 5410
 E-mail merck@merck.com.co
 Internet www.merck.com.co

COSTA RICA

Merck S.A.
 12 ave. 0-33, Zona 2 de Mixco
 CIUDAD DE GUATEMALA
 Phone +502 2410 2400
 +502 2410 2300 [Chemicals]
 Telefax +502 2434 2954
 E-mail quimicos@merck.com.gt
 Internet www.merck.com.gt

CROATIA

Merck d.o.o.
 Andrije Hebranga 32
 10000 ZAGREB
 Phone +385 1 4864 111
 Telefax +385 1 4864 190
 E-mail merck@merck.hr
 Internet www.merckserono.com

CUBA

Merck S.A.
 Calle 3 era."A" No. 15209, 152 y 154
 Reparto Náutico
 CIUDAD HABANA
 Phone +537 208 7903 04
 Telefax +537 208 7686
 E-mail myanes@enet.cu
 Internet www.merck-chemicals.com

CYPRUS

A.J. Vouros Ltd.
 14 Propontidos Street
 Strovolos Industrial Area
 2090 NICOSIA
 Phone +357 22 879 922
 Telefax +357 22 767 158
 E-mail klitosth@logosnet.cy.net

CZECH REPUBLIC

Merck spol. s r.o.
 Na Hebezech II, 1718/10
 140 00 PRAHA 4
 Phone +420 (0) 272 084 272
 Telefax +420 (0) 272 084 303
 E-mail chemie@merck.cz
 Internet www.merck-chemicals.cz

DENMARK

REAGENTS AND LABORATORY PRODUCTS
 VWR - Bie & Berntsen A/S
 Transformervej 8
 2730 HERLEV
 Phone +45 43 868 788
 Telefax +45 43 868 790
 E-mail info@dk.vwr.com
 Internet www.vwr.com

CHEMICALS FOR PRODUCTION

Merck A/S
 Strandvejen 102 B
 2900 HELLERUP
 Phone +45 7020 7660
 Telefax +45 7020 7640
 E-mail britta.hansen@merck.de
 helmi.selin@merck.de
 info@dk.vwr.com

Millipore A/S
 Fruebjergvej 3
 Postbox 84
 2100 KOEBENHAVN

DOMINICAN REPUBLIC

Merck S.A.
 12 ave. 0-33, zona 2 de Mixco
 CIUDAD DE GUATEMALA
 Phone +502 2410 2400
 +502 2410 2300 [Chemicals]
 Telefax +502 2434 2954
 E-mail quimicos@merck.com.gt
 Internet www.merck.com.gt

ECUADOR

Merck Ecuador C.A.
 Avda. Amazonas 4545 y Pereira
 Edificio Centro Financiero - Piso 6
 QUITO
 Phone +593 2 2981 677
 Telefax +593 2 2981 644
 E-mail sicmerck@merck.com.ec
 Internet www.merck.com.ec

EGYPT

Nefertiti Chemicals Co.
 Armanious Group Tower, 9 El Sharekat Street,
 behind Kekhia Mosque, Opera Square, Abdeen
 CAIRO
 Phone +20 2 2399 2700
 Telefax +20 2 2399 2783
 E-mail nefertiti@nefertitichem.com

EL SALVADOR

Merck S.A.
 12 ave. 0-33, Zona 2 de Mixco
 CIUDAD DE GUATEMALA
 Phone +502 2410 2400
 +502 2410 2300 [Chemicals]
 Telefax +502 2434 2954
 E-mail quimicos@merck.com.gt
 Internet www.merck.com.gt

ESTONIA

JS Chemistry Ltd.
 Akademiastr. 21D
 12618 TALLINN
 Phone +372 660 8464
 Telefax +372 660 5485
 E-mail svetlana@jskeemia.ee

FINLAND

REAGENTS AND LABORATORY PRODUCTS

VWR International Oy
Valimotie 9
00380 HELSINKI
Phone +358 (0) 9 8045 51
Telefax +358 (0) 9 8045 5200
E-mail info@fi.vwr.com
Internet www.vwr.com

CHEMICALS FOR PRODUCTION

Merck Oy
Pihatörmä 1 C 2
02240 ESPOO
Phone +358 (0) 9 8678 7078
Telefax +358 (0) 9 8678 7077
E-mail logistics_finland@merck.de
Internet www.merck.fi

Millipore Oy
Pihatörmä 1 C
02240 ESPOO
Phone +358 (0) 2030 5645 [Customer service]
Telefax +358 (0) 2030 5644
E-mail asiakaspalvelu@merckgroup.com
Internet www.millipore.com

FRANCE

REAGENTS AND LABORATORY PRODUCTS

VWR International S.A.S.
Le Périgares – Bâtiment B
201, rue Carnot
94126 FONTENAY-SOUS-BOIS CEDEX
Phone +33 (0) 8250 23030 [0.15 Euro CCT/min]
Telefax +33 (0) 8250 23035 [0.15 Euro CCT/min]
E-mail info@fr.vwr.com
Internet www.vwr.com

CHEMICALS FOR PRODUCTION

Merck Chimie S.A.S.
Immeuble Périgares 201, Rue Carnot
94126 FONTENAY-SOUS-BOIS CEDEX
Phone +33 (0) 1 4394 5400
Telefax +33 (0) 1 4394 5125
Internet www.merck.fr

GERMANY

REAGENTS AND LABORATORY PRODUCTS

VWR International GmbH
Hilpertstr. 20a
64295 DARMSTADT
Phone +49 (0) 180 570 2000
Telefax: +49 (0) 180 570 2222
E-mail info@de.vwr.com
Internet <https://de.vwr.com>

Merck KGaA
Frankfurter Str. 250
64293 DARMSTADT
Phone +49 (0) 6151 72 0
Telefax +49 (0) 6151 72 2000
E-mail service@merck.de
Internet www.merck.de

Merck Schuchardt OHG
Eduard-Buchner-Str. 14-20
85662 HOHENBRUNN
Phone +49 (0) 8102 8020
Telefax +49 (0) 8102 8021 75
E-mail schuchardt-vertrieb@merck.de
Internet www.schuchardt.de

BIOCHEMICALS

Merck Biosciences GmbH
Ober der Röth 4
65824 SCHWALBACH
Phone +49 (0) 6196 63955
Telefax +49 (0) 6196 62361
E-mail customer.service@merckbio.eu
www.merck-chemicals.com/life-science-research

GREAT BRITAIN

REAGENTS AND LABORATORY PRODUCTS

VWR International Ltd.
Hunter Boulevard, Magna Park, Lutterworth
LEICESTERSHIRE LE17 4 XN
Phone +44 (0) 800 223 344
Telefax +44 (0) 1455 558 586
E-mail uksales@uk.vwr.com
Internet <https://uk.vwr.com>

CHEMICALS FOR PRODUCTION

Merck Chemicals Ltd.
Boulevard Industrial Park, Padge Road, Beeston
NOTTINGHAM NG9 2JR
Phone +44 (0) 115 957 4204
Telefax +44 (0) 115 957 4237
E-mail chemicals@merckchem.co.uk
Internet www.merckchem.co.uk

LIFE SCIENCE RESEARCH PRODUCTS

Merck Chemicals Ltd.
Boulevard Industrial Park, Padge Road, Beeston
NOTTINGHAM NG9 2JR
Phone +44 (0) 115 943 0840
Telefax +44 (0) 115 943 951
E-mail Customer.service@merckbio.eu
Internet www.merck4biosciences.com

GREECE

Merck A.E Hellas
Chemical Division
41-45 Kifissias Av. (Building B)
15123 MAROUSI, ATHENS
Phone +30 210 6165 100
Telefax +30 210 6101-386
E-mail Merck.Chem.gr@merck.de
Internet www.merck-chemicals.gr

GUATEMALA

Merck S.A.
12 ave. 0-33, Zona 2 de Mixco
CIUDAD DE GUATEMALA
Phone +502 2410 2400
+502 2410 2300 [Chemicals]
Telefax +502 2250 5193
E-mail quimicos@merckgroup.com
Internet www.merck-chemicals.com.gt

HONDURAS

Merck S.A.
12 ave. 0-33, Zona 2 de Mixco
CIUDAD DE GUATEMALA
Phone +502 2410 2400
+502 2410 2300 [Chemicals]
Telefax +502 2434 2954
E-mail quimicos@merck.com.gt
Internet www.merck.com.gt

HUNGARY

Merck Kft.
Oktober huszonharmadika utca 6-10
1117 BUDAPEST
Phone +36 1 4638 100
Telefax +36 1 4638 101
E-mail kemia@merck.hu
Internet www.merck.hu

INDIA

Merck Specialities Private Limited
Lloyds Centre Point, 1st floor,
Appasaheb Marathe, Marg Prabhadevi,
MUMBAI 400 025
Phone +91 (022) 6663 9800 [Marketing]
+91 (022) 6794 4309 [Customer Services]
Telefax +91 (022) 6663 9893 [Marketing]
+91 (022) 6794 4311 [Customer Services]
E-mail lsa@merck.co.in
Internet www.merckspecialities.com

INDONESIA

P.T. Merck Tbk.
JL. T.B. Simatupang No. 8
Pasar Rebo
JAKARTA 13760
Phone +62 21 2856 5600
Telefax +62 21 2856 5603
E-mail chemicals@merckgroup.com
Internet www.merck.co.id

IRELAND

REAGENTS AND LABORATORY PRODUCTS

VWR International Ireland Orion Business Campus
Northwest Business Park
Ballycoolin
DUBLIN 15
Phone +353 (0) 1 882 2222
Telefax +353 (0) 1 882 2333
E-mail sales@ie.vwr.com
Internet <https://ie.vwr.com>

CHEMICALS FOR PRODUCTION

Merck Chemicals Ltd.
Boulevard Industrial Park, Padge Road, Beeston
NOTTINGHAM NG9 2 JR
Phone 00800 1133 5588
Telefax 00800 1133 5599
E-mail chemicals@merckchem.ie
Internet www.merckchem.ie

LIFE SCIENCE RESEARCH PRODUCTS

Merck Chemicals Ltd.
Boulevard Industrial Park, Padge Road, Beeston
NOTTINGHAM NG9 2 JR
Phone +44 (0) 115 943 0840
Telefax +44 (0) 115 943 0951
E-mail Customer.service@merckbio.eu
Internet www.merck4biosciences.com

ISRAEL

MERCURY
Scientific & Industrial Products Ltd.
P. O. Box 159
12, Ha'avoda St.
ROSH HA'AYIN 48101
Phone +972 (0) 3 9387 164
Telefax +972 (0) 3 9387 174
E-mail mercury@mercury-ltd.co.il

ITALY

REAGENTS AND LABORATORY PRODUCTS

VWR International s.r.l.
Via Stephenson 94
20157 MILAN
Phone +39 02 3320 311
Telefax +39 800 1529 99
E-mail info@it.vwr.com
Internet www.vwr.com

CHEMICALS FOR PRODUCTION

Merck S.p.A.
Via G. Stephenson
9420157 MILAN
Phone +39 02 3320 351
Telefax +39 02 3320 35206
E-mail infochimica@merck.it

JAPAN

Merck Ltd. Japan
ARCO Tower 5F
8-1, Shimomoguro 1-chome, Meguro-ku
TOKYO 153-8927
Phone +81 (0) 3 5434 4700
Telefax +81 (0) 3 5434 5076
E-mail service@merck.co.jp
Internet www.merck.co.jp

JORDAN

Henry Marroum Et Sons
Lab. Serve
P. O. Box 589
AMMAN 11118
Phone +962 (0) 6 5651 505
Telefax +962 (0) 6 5651 510
E-mail fmarroum@labserve.com.jo
Internet www.labserve.com.jo

KUWAIT

REAGENTS AND LABORATORY PRODUCTS

KUWAIT Lab
General Trad. Et Cont. Est.
P.O.Box 44693
KUWAIT
Phone +965 2633 373 / -374
Telefax +965 2633 375
E-mail kwcreativity@yahoo.com

CHEMICALS FOR PRODUCTION

Solyman Services (UK) Ltd.
Sharjah Airport International
Free Zone
P.O.Box 8611
SHARJAH, U.A.E.
Phone +971 6557 2266
Telefax +971 6557 2271
E-mail ssl.dxb.chem@solymanservices-me.com

LATVIA

Antols-HIM Ltd.
Lubanas Str. 125A-20
RIGA LV-1021
Phone +371 6601 6379
Telefax +371 6601 6377
E-mail andrejs.kudins@antols-him.lv

LEBANON

Chemical Et General Suppliers S.A.R.L.
Achrafieh-Fassouh- Mgr. Atalla Street
Maria Del Carmen Bldg.
P.O.Box 16
5908 BEIRUT
Phone +961 (0) 1 337 654
Telefax +961 (0) 1 337 654
E-mail cgsleb@dm.net.lb

LITHUANIA

UAB BIOEK SMA
Moksliniku g. 11
08412 VILNIUS
Phone +370 5 272 9721
Telefax +370 5 272 9712
E-mail mindaugas.pupevicius@bioeksma.lt

LUXEMBOURG

VWR International BVBA
Researchpark Haasrode 2020
Geldenaaksebaan 464
3001 LEUVEN
Phone +32 (0) 16 385 011
Telefax +32 (0) 16 385 35
E-mail customerservice@be.vwr.com

MACEDONIA

Varus
Representative Merck HSEE
Ul. Skupi bb.
1000 SKOPJE
Phone +389 (0) 2 311 5122
Telefax +389 (0) 2 313 7013
E-mail varus@varus.com.mk

MALAYSIA

MERCK SDN BHD
Level 3, Menara Sunway Annexe
Jalan Lagoon Timur, Bandar Sunway,
46150 Petaling Jaya
SELANGOR DARUL EHSAN
Phone +603 7494 3688
Telefax +603 7492 0151 [F&T/Logistics]
+603 7880 0792
+603 7492 0231 [Consumer Health Care]
+603 7491 9280 [Merck Serono]
+603 7491 0850 [Chemicals]
+603 7491 0860
E-mail chemlab@merck-de.com.my
Internet www.merck.com.my

MÉXICO

Merck, S.A. de C.V.
Calle 5 No.7, Fraccionamiento Ind. Alce Blanco,
c.p. 53370 Naucalpan de Juárez
EDO. DE MEXICO
Phone +52 (0) 55 2122 1600
Telefax +52 (0) 55 2122 1652
Internet www.merck.com.mx

MOROCCO

VWR International S.A.S.
"Le Périgares" - Bât. B
201, rue Carnot
94126 FONTENAY-SOUS-BOIS CEDEX
Phone +33 (0) 1 4514 8500
E-mail info@fr.vwr.com
Internet www.vwr.com

NETHERLANDS

REAGENTS AND LABORATORY PRODUCTS

VWR International B.V.
Postbus 8198
1005 AD AMSTERDAM
Phone +31 (0) 20 480 8400
Telefax +31 (0) 20 480 8480
E-mail info@nl.vwr.com
Internet www.vwr.com

CHEMICALS FOR PRODUCTION

Merck BV
Tupolevlaan 41-61
1119 NW SCHIPHOL-RIJK
Postbus 75768
1118 ZX SCHIPHOL
Phone +31 (0) 20 567 2809
Telefax +31 (0) 20 567 5566
E-mail NLcustomerserviceMM@merckgroup.com
Internet www.merck-chemicals.nl

Millipore Customer Service Centre
Haarlerbergpark River Building, 3rd floor
Haarlerbergweg 33
1101 CH AMSTERDAM ZUIDOOST
Phone 0900 7 645 645 [local]
+31 (0) 20 567 5074 [international]

NEW ZEALAND

Merck Ltd., New Zealand
22 Hobill Avenue
PO Box 76171
MANUKAU CITY 2104, AUCKLAND
Phone +64 (0) 6 356 7328
Telefax +64 (0) 6 356 7311
E-mail info@merck.co.nz
Internet www.merck-chemicals.co.nz

NICARAGUA

Merck S.A.
12 ave. 0-33, Zona 2 de Mixco
CIUDAD DE GUATEMALA
Phone +502 2410 2400
+502 2410 2300 [Chemicals]
Telefax +502 2434 2954
E-mail quimicos@merck.com.gt
Internet www.merck.com.gt

NORWAY

REAGENTS AND LABORATORY PRODUCTS

VWR International AS
Haavard Martinsens vei 30
0978 OSLO
Phone +47 (0) 2290
Telefax +47 8150 0940
E-mail info@no.vwr.com

Millipore AS
Karihaugveien 89
1086 OSLO
Phone +47 8106 2645
Telefax +47 8106 2644
E-mail norway@merckgroup.com

OMAN

Solyman Services (UK) Ltd.
Sharjah Airport International
Free Zone
P.O.Box 8611
SHARJAH, U.A.E.
Phone +971 6557 2266
Telefax +971 6557 2271
E-mail ssl.dxb.chem@solymanservices-me.com

PAKISTAN

Merck (Private) Limited
D/7, Shaheed-e-Millat Road
75350 KARACHI
Phone +92 (0) 21 4559 210 17
+92 (0) 21 111 523 523 [U.A.N.]
Telefax +92 (0) 21 4559 221
+92 (0) 21 4535 294
E-mail info@merck.com.pk
Internet www.merck.com.pk

PANAMA

Merck S.A.
12 ave. 0-33, Zona 2 de Mixco
CIUDAD DE GUATEMALA
Phone +502 2410 2400
+502 2410 2300 [Chemicals]
Telefax +502 2434 2954
E-mail quimicos@merck.com.gt
Internet www.merck.com.gt

PARAGUAY

Vicente Scavone y Cia. C.I.S.A.
Pastora Cespedez y Don Vicente Scavone
SAN LORENZO
Phone +595 (0) 21 522 322
Telefax +595 (0) 21 522 322
E-mail crizzi@lasca.com.py

PERU

Merck Peruana S.A.
Av. Los Frutales No. 220 Ate
LIMA 3
Phone +51 (0) 1 618 7500
Telefax +51 (0) 1 437 2955
E-mail merck.peruana@merckgroup.com
Internet www.merck.com.pe

PHILIPPINES

Merck, Inc.
24th floor GT Tower International
6813 Ayala Avenue corner
H.V. dela Costa Street
Salcedo Village
1227 MAKATI CITY
Phone +63 (0) 2 815 4067
Telefax +63 (0) 2 815 4882 / -4883
E-mail customer.care@merck.ph
Internet www.merck.ph

POLAND

Merck Sp. z o.o.
Al. Jerozolimskie 178
02-486 WARSZAWA
Phone +48 (0) 22 5359 770
+48 (0) 22 5359 700
Telefax +48 (0) 22 5359 945
+48 (0) 22 5359 703
E-mail dzial.handlowy@merck.pl
Internet www.merck-chemicals.pl

PORTUGAL

REAGENTS AND LABORATORY PRODUCTS

VWR International, – Material de Laboratório, Lda
Edifício NEOPARK
Av. Tomás Ribeiro, no 43, 3-D
2790-221 CARNAXIDE
Phone +351 21 3600 770
Telefax +351 21 3600 7989
E-mail info@pt.vwr.com
Internet www.vwr.com

CHEMICALS FOR PRODUCTION

Merck S.A.
Rua Alfredo da Silva, 3-C
1300-040 LISBON
Phone +351 21 361 3510
Telefax +351 21 361 3662
E-mail carla.pinto@merck.pt
Internet www.merck.pt

QATAR

Solyman Services (UK) Ltd.
Sharjah Airport International
Free Zone
P.O.Box 8611
SHARJAH, U.A.E.
Phone +971 6557 2266
Telefax +971 6557 2271
E-mail ssl.dxb.chem@solymanservices-me.com

ROMANIA

Merck Romania S.R.L.
Calea Pleveni 139, copr C, et.2, Sector 6
060011 BUCURESTI
Phone +40 (0) 21 319 8850
Telefax +40 (0) 21 319 8848
E-mail info.merck@merck.ro
Internet www.merck.ro

RUSSIA

LLC MERCK
ul. Smolnaya, 24/D
125445 MOSCOW
Phone +7 495 937 3304
Telefax +7 495 937 3305
E-mail toroptseva@merck.co.ru
Internet www.merck.ru

SAUDI ARABIA

LABORATORY PRODUCTS

Saleh Et Abdulaziz Abahsain Co. Ltd.
P.O.Box 209
AL-KHOBAR 31952
Phone +966 (3) 898 4045
Telefax +966 (3) 895 1160
E-mail abahsain@sahara.com.sa

CHEMICALS FOR PRODUCTION

Solyman Services (UK) Ltd.
P. O. Box 4946
JEDDAH 21411
Phone +966 (2) 663 3108
Telefax +966 (2) 663 2212
E-mail ksachemicals@solymanservices.com
ksafoods@solymanservices.com

SERBIA

Novos d.o.o.
Representation Merck HSEE.
Cara Dusana 207
11080 BELGRAD – ZEMUN
Phone +381 (0) 11 377 3503
Telefax +381 (0) 11 377 3504
E-mail novos@beocity.net
novos@infosky.net

SINGAPORE

Merck Pte. Ltd.
3 International Business Park
#02-01 Nordic European Centre
SINGAPORE 609927
Phone +65 6890 6761
Telefax +65 6890 6639
E-mail Selena.Goh@merck.sg
techsupport@merck.sg [technical support]
Internet www.merck.chemicals.sg

SLOVAKIA

Merck spol. s r.o.
Tuhovská 3
831 06 BRATISLAVA
Phone +421 (0) 2 4926 7276
Telefax +421 (0) 2 4926 7799
E-mail chemia@merck.sk

SLOVENIA

Merck d.o.o.
Ameriška ulica 8
1000 LJUBLJANA
Phone +386 1 560 3800
Telefax +386 1 560 3830
E-mail info@merck.si
Internet www.merck.si

SOUTH AFRICA

Merck Pty. Ltd. Chemicals Division
P. O. Box 1998
HALFWAY HOUSE 1685
Phone +27 (0) 8600 63725
Telefax +27 (0) 11 345 9251
E-mail labsupply@merck.co.za
Internet www.merck.co.za

SOUTH KOREA

Merck Ltd.
15th floor, Haesung-2-Bldg.,
942-10 Daechi-3-dong, Kangnam-gu
SEOUL 135-725
Phone +82 (0) 2 2185 38403
Telefax +82 (0) 2 2185 3830
E-mail products@merck.co.kr
Internet www.merck.co.kr

SPAIN

REAGENTS AND LABORATORY PRODUCTS

VWR International Eurolab S.L.
C/ Tecnología 5-17
A-7-Llinars Park
08450 LLINARS DEL VALLÉS
BARCELONA
Phone +34 (0) 902 222 897
Telefax +34 (0) 902 430 657
E-mail info@es.vwr.com
Internet www.vwr.com

CHEMICALS FOR PRODUCTION

MERCK SL
Polígono Merck
08100 MOLLET DES VALLÉS
BARCELONA
Phone +34 (0) 93 565 5538
Telefax +34 (0) 93 544 0285
E-mail comunicaci3n@merck.es
Internet www.merck.es

SWEDEN

REAGENTS AND LABORATORY PRODUCTS

VWR International AB
Fagerstagatan 18 A
16394 STOCKHOLM
Phone +46 (0) 8 621 3400
Telefax +46 (0) 8 621 3466
E-mail info@se.vwr.com
Internet www.vwr.com

CHEMICALS FOR PRODUCTION

Merck AB
Box 3033
169 03 SOLNA
Phone +46 (0) 8 5456 6960
Telefax +46 (0) 8 5456 6969
E-mail kemi@merck.se
Internet www.merck.se

Millipore AB
c/o Merck AB
Box 3033
169 03 SOLNA
Phone +46 (0) 771 200 645
Telefax +46 (0) 771 200 644
E-mail kundservice@merckgroup.com

SWITZERLAND

REAGENTS AND LABORATORY PRODUCTS

VWR International AG
Lerzenstr. 16/18
8953 DIETIKON
Phone +41 (0) 44 745 1313
Telefax +41 (0) 44 745 1310
E-mail info@ch.vwr.com
Internet www.vwr.com

VWR International SA

Rue Neuve 7
1260 NYON
Phone +41 (0) 22 994 9100
Telefax +41 (0) 22 994 9109
E-mail info@ch.vwr.com
Internet www.vwr.com

CHEMICALS FOR PRODUCTION

Merck (Schweiz) AG
Chamerstrasse 174
6300 ZUG
Phone +41 (0) 41 729 2303
Telefax +41 (0) 41 729 2300
E-mail chemie@merck.ch
Internet www.merck.ch

SYRIA

Droguerie Syrie
Kostaki Homsy Street 106, Suite 3
P. O. Box 5441
ALEPPO
Phone +963 (0) 21 2299 000
Telefax +963 (0) 21 2299 215
E-mail sales@drogueriesyrie.com

TAIWAN

Merck Ltd.
6F., No. 89, Sec. 2, Tiding Blvd., Neihu Dist.
TAIPEI City 114
Phone +886 2 2162 1111
Telefax +886 2 8751 6262
E-mail service@merck.com.tw
Internet www.merck.com.tw

THAILAND

Merck Ltd.
622 Emporium Tower, 19th floor,
Sukhumvit Rd., Klongton, Klongtoey
BANGKOK 10110
Phone +66 (0) 2 667 8000
Telefax +66 (0) 2 667 8338
E-mail customerservice@merck.co.th
Internet www.merck.co.th

TUNISIA

VWR International S.A.S.
"Le Périgares" – Bât. B
201, rue Carnot
94126 FONTENAY-SOUS-BOIS CEDEX
Phone +33 (0) 1 45 148 500
E-mail info@fr.vwr.com
Internet www.vwr.com

TURKEY

MERCK İLAÇ ECZA VE KİMYA TİC. A.Ş.
Kayisdagi Caddesi, Karaman Ciftligi Yolu
Kar Plaza, No 45 Kat 7,
34752 ICERENKOY-İSTANBUL
Phone +90 216 5786 600
Telefax +90 216 4690 922
E-mail info@merck-chemicals.com.tr
Internet www.merck-chemicals.com.tr

U.A.E.

REAGENTS AND LABORATORY PRODUCTS

Laboratory Scientific Supplies FZC
C-21, Gate No. 4
Aiman Free Zone
P.O. Box 5197
AJMAN
Phone +971 (6) 7408 841 / -842
Telefax +971 (6) 7408 843
E-mail lsscheme@emirates.net.ae

CHEMICALS FOR PRODUCTION

Solyman Services (UK) Ltd.
Sharjah Airport International
Free Zone
P.O. Box 8611
SHARJAH
Phone +971 (6) 557 2266
Telefax +971 (6) 557 2271
E-mail ssl.dxb.chem@solymanservices-me.com

UKRAINE

Witec Group Ltd.
Gaidar str. 13, of. 806
65078 ODESSA
Phone +38 (0) 48 777 9175
Telefax +38 (0) 48 777 9173
E-mail info@witec.com.ua
ILLYA.KUTSENKO@witec.com.ua
Internet www.witec.com.ua

Chemlaborreactiv Ltd.
Schelkivska 8, Kyivskiy reg.
007400 BROVARY
Phone +38 (0) 44 494 4242
Telefax +38 (0) 44 494 4242
E-mail bereshuk@chemlab.kiev.ua

URUGUAY

Técnica del Plata LTDA.
W Ferreira Aldunate 1234
MONTEVIDEO 11100
Phone +598 2908 4866
Telefax +598 2908 5505
E-mail info@tecnicalplata.com.uy

Merck Millipore around the world

USA

EMD Millipore Corporation
290 Concord Road
BILLERICA, MA 01821
Phone +1 800 222 0342
+1 978 715 4321
Telefax +1 800 776 0999
Email Customer.CareDesk@merckgroup.com
Internet www.emdmillipore.com

UZBEKISTAN

FORTEK
28, Katartal Str., floor 7
700135 TASHKENT
Phone +998 (71) 173 9301
Telefax +998 (71) 173 9302
E-mail office@fortek.uz

Nycomed Austria GmbH
Representative Office in Uzbekistan
Turaba Tuly Str. 1
700003 TASHKENT
Phone +998 (71) 139 1681
Telefax +998 (71) 139 1508
E-mail ALLI@nycomed.com

VENEZUELA

Merck S.A.
Calle Hans Neumann
Edificio Corimón, Piso 3
Los Cortijos de Lourdes
Apartado 2020
CARACAS
Phone +58 (0) 212 235 1379
Telefax +58 (0) 212 237 9434
E-mail mven@merck.com.ve
Internet www.merck.com.ve

VIETNAM

Merck Ltd.
9th floor, Centre Point,
106 Nguyen Van Troi St.,
Phu Nhuan District,
HO CHI MINH CITY
Phone +84 8 (0) 3842 0100
Telefax +84 8 (0) 3842 0120
E-mail merckvn-care@merck.vn
merckserono@merck.vn

YEMEN

Solyman Services (UK) Ltd.
Sharjah Airport International
Free Zone
P.O.Box 8611
SHARJAH, U.A.E.
Phone +971 6557 2266
Telefax +971 6557 2271
E-mail ssl.dxb.chem@solymanservices-me.com



Merck Millipore in the world wide web
www.merck-chemicals.com/chromatography

Analytical Application Finder ...



Searching for applications?
View our Analytical Application Finder with many
applications available that are easy to find.



www.merck-chemicals.com/aaf

... and more education material

You want to keep yourself updated? No problem. We keep you informed about:

- Interesting education material that is regularly updated
- Events where you can meet us
- All of our brochures at one place – no more searching



www.merck-chemicals.com/education

We provide information and advice to our customers on application technologies and regulatory matters to the best of our knowledge and ability, but without obligation or liability. Existing laws and regulations are to be observed in all cases by our customers. This also applies in respect to any rights of third parties. Our information and advice do not relieve our customers of their own responsibility for checking the suitability of our products for the envisaged purpose.

Amberjet®, Amberlite®, Amberlyst® and Triton® are registered trademarks of Rohm and Haas Co.; Avicel® is a trademark of FMC Corp., Philadelphia; Chelex® is a registered trademark of Bio-Rad Laboratories, Inc.; Dowex® is a registered trademark of the Dow Chemical Co.; Florisil® is a registered trademark of U.S. Silica Company (www.u-s-silica.com); LaChrom® is a registered trademark of VWR International, Hitachi Ltd and Hitachi High-Technologies Corp.; Luer-Lok® is a registered trademark of Becton Dickinson; Nucleosil® is a trademark of Macherey-Nagel, Düren; UPLC® is a registered trademark of Waters Corporation.

Fluoropore™, Millex Samplicity™ and Samplicity™ are trademarks of Merck KGaA, Darmstadt, Germany. Aluspher®, CapRod®, ChiraDex®, Chromolith®, Durapore®, EcoCART®, Elix®, EXTrelut®, Hibar®, Jetpore®, LiChroCART®, LiChrolut®, LiChroprep®, LiChropur®, LiChrosolv®, LiChrosorb®, LiChrospher®, LiChroTest®, LuxPlate®, manu-CART®, Millex®, Millipore Express®, Millitrack®, Millivac®, Milli-Q®, Omnipore®, Prepsolv®, Progard®, ProteoChrom®, Purospher®, SeQuant®, Stericup®, Steritop®, Superspher®, SupraSolv®, UniSolv®, ZIC®-HILIC and ZIC®-pHILIC are registered trademarks of Merck KGaA, Darmstadt, Germany.

For further information on Merck Millipore
and our products contact:

Merck KGaA
64271 Darmstadt, Germany
E-mail: chromatography@merckgroup.com
www.merck-chemicals.com/chromatography